

Thesis  
2576

**An Evaluation of Distributed Cogeneration for  
Disaggregated Consumer Populations on Islands:  
the Case of Guernsey**

**Derrick Fielden  
B.Sc.(Eng.), M.A., C.Eng., MIEE**

**Thesis submitted for the degree of  
Doctor of Philosophy**

**Department of Management Science  
The School of Management  
University of Stirling**

**February 1995**

THIS VOLUME HAS A  
VERY TIGHT BINDING

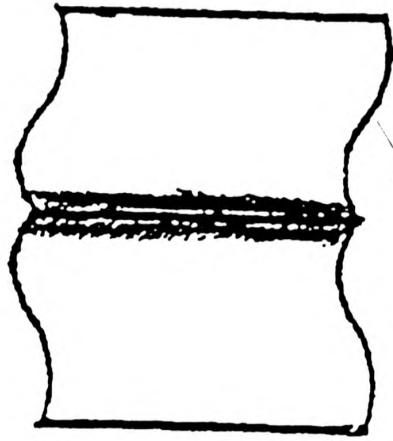

# NUMEROUS ORIGINALS IN COLOUR

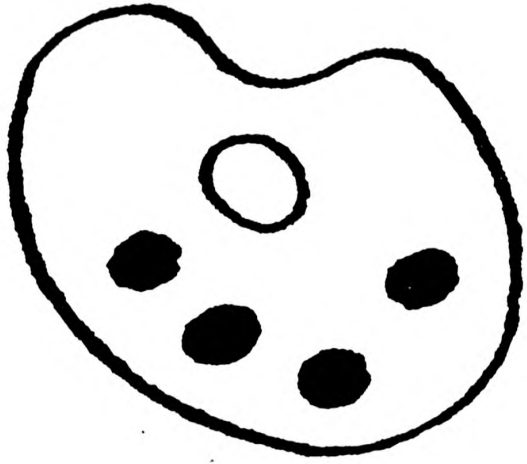

## Table of Contents

	Page No.
List of Tables . . . . .	vii
List of Figures . . . . .	xii
Acknowledgements . . . . .	xxii
Abstract . . . . .	xxiii
<b>CHAPTER 1 - Introduction</b>	
1.1 The island of Guernsey . . . . .	1
1.2 Island government . . . . .	4
1.3 Guernsey today . . . . .	7
1.4 Parish energy flows . . . . .	10
1.5 The energy problem . . . . .	17
1.6 Holistic energy conservation . . . . .	21
1.7 A wider view is required . . . . .	26
1.8 Energy service delivery . . . . .	31
<b>CHAPTER 2 - Energy and the Island Economy</b>	
2.1 Raising the quality of the debate . . . . .	35
2.2 The economy . . . . .	39
2.3 Energy per capita . . . . .	46
2.4 Inadequate energy policies . . . . .	50
2.5 Co-ordination . . . . .	53
2.6 Direct intervention . . . . .	54
2.7 Disaggregated information . . . . .	57

**CHAPTER 3 - Methodologies employed**

3.1	Approach to the energy problem . . . . .	61
3.2	Systems thinking and the energy situation . .	68
3.3	Conceptual model building . . . . .	74
3.4	The SOGEMS model . . . . .	81
3.5	Resolution levels 2 and 3 . . . . .	83
3.6	Comparison with the real world . . . . .	87

**CHAPTER 4 - Aggregate (Historical) Energy Trends**

4.1	Primary energy imports . . . . .	90
4.2	Primary energy pricing . . . . .	100
4.3	The supply and distribution of energy . . . .	104
4.4	Delivered energy pricing . . . . .	112

**CHAPTER 5 - Final User Fuel Trends and System Changes**

5.1	Delivered energy flows . . . . .	116
5.2	The end-user energy market . . . . .	125
5.3	The general trend . . . . .	135
5.4	Energy conversion . . . . .	139
5.5	Who are the end-users ? . . . . .	141

**CHAPTER 6 - 'Dynamic' Context of the System Model**

6.1	Parish energy demands . . . . .	147
6.2	Clusters of QQT demands . . . . .	159
6.3	Abstractions of parish based QQT demands . . .	165
6.4	Legislation relating to the energy sector . .	175

**CHAPTER 7 - Energy Modelling of the System and its Components**

7.1	Sub-systems bridge . . . . .	180
7.2	Computer model building. . . . .	185
7.3	Methodology of the Guernsey energy model . . . . .	188
7.4	The process of modelling . . . . .	195
7.5	Cogeneration planning . . . . .	204
7.6	Energy service delivery . . . . .	211
7.7	Validation of results . . . . .	234

**CHAPTER 8 - The Behaviour of the System**

8.1	Inappropriate planning methods . . . . .	239
8.2	Energy availability . . . . .	244
8.3	Poor demand side energy efficiency . . . . .	251
8.4	Mismatching of energy QUALITY . . . . .	268
8.5	Accounting for the environment . . . . .	277

**CHAPTER 9 - The QQT Matching Process of the System**

9.1	ESCo flexibility . . . . .	288
9.2	ESCo QQT models . . . . .	296
9.3	Location specific renewable sources . . . . .	319
9.4	Computer aided planning of heating networks . . . . .	339
9.5	Supply/demand uncertainty . . . . .	345
9.6	Smooth demand curves . . . . .	347

**CHAPTER 10 - The Vectors for and Consequences of Changing the System**

10.1	A case for the States to look at energy in a total systems sense . . . . .	355
10.2	ESCO accountability . . . . .	363
10.3	Influencing role for parish energy users . . .	367
10.4	The requirements of other States committees . . . . .	371
10.5	Regulatory interventions . . . . .	374
10.6	Embedded cogeneration and the Island electricity network . . . . .	380

**CHAPTER 11 - The Costs of Changing the System**

11.1	The costs of serving each parish . . . . .	396
11.2	Competing options . . . . .	400
11.3	Heating networks . . . . .	416
11.4	Longer term (30 year) benefits . . . . .	422
11.5	Longer term (30 year) costs . . . . .	430
11.6	ESCO demand side projects (the next step). . .	444

**CHAPTER 12 - Conclusion**

12.1	The need for a new systemic emphasis . . . . .	454
12.2	Strategic energy conservation . . . . .	463
12.3	From strategy to the tactics of action . . . .	468
12.4	Further work . . . . .	472
12.5	Retrospective and failings of the research . .	476
12.6	Chasing the virtuous circle . . . . .	481

**APPENDICES**

A.	Energy measurement . . . . .	489
B.	Resolution Level 3 sub-system models. . . . .	492
C.	Parish band four energy end-users . . . . .	499
D.	Support environments and graphical techniques . . .	516
E.	Guernsey energy model source code programs (PhD.prg, PhD00 - PhD60.prg) . . . . .	518
F.	Typical diurnal and seasonal electricity profiles for hotels and vineries . . . . .	534
G.	Diurnal electricity demand profiles for unrestricted domestic (winter weekday) annual consumption ranges (42F) . . . . .	537
H.	Capital cost of cogeneration (diesel based) plant (1992, not including waste and supplementary heat boilers). . . . .	539
I.	QQT Data for the Forest abstraction sites . . . . .	541
J.	Diversified demand (or coincident demand) . . . . .	545
K.	Final parish diurnal electricity profiles . . . . .	547
L.	ESCO monthly heat averages . . . . .	552
M.	Sample diurnal heat profiles to back-up assertions on 'peak', 'base load' and 'expected' (probabilistic) incomes from cogeneration . . . . .	562
N.	Probable ESCo composite (maximum) diurnal heat profiles . . . . .	565

**BIBLIOGRAPHY**

Works cited by Chapter . . . . .	571
Cited Author index . . . . .	605



## LIST OF TABLES

- TABLE 2.1 - Main economic indicators (% changes - 1990 values)
- TABLE 3.1 - A grouping of system methodologies based upon assumptions made about problem situations
- TABLE 4.1 - Sales/Capital employed 1988/89
- TABLE 4.2 - Guernsey Gas Light Company Limited, contribution to turnover - 1989
- TABLE 4.3 - U.K. regional HFO average price (pence/litre)
- TABLE 4.4 - British Fuels Limited - House coal (£/tonne) 1990
- TABLE 4.5 - Rates of duty (pence/litre) - 28 November 1988
- TABLE 4.6 - 1990 Annual coal shipments
- TABLE 4.7 - 900 Litre delivery of Kerosene (1992 prices)
- TABLE 4.8 - Cost of SEB generation for a typical month of 1992
- TABLE 4.9 - Typical tariff costs in the domestic energy market
- TABLE 4.10 - Tariff costs in the transport energy market (1992)
- TABLE 5.1 - Generating units currently installed at the central power station site (Vale)
- TABLE 6.1 - Band 4 end-users and their contribution to production electrical energy demand
- TABLE 6.2 - The largest end-users in each economic sector, within each parish
- TABLE 6.3 - Abstractions and their contribution to production electrical energy demand in each parish
- TABLE 7.1 - Basic cogeneration parameters
- TABLE 7.2 - Forest tourism sector (1990)
- TABLE 7.3 - Forest vinery sector (1990)
- TABLE 7.4 - Forest commercial/public building sector (1990)
- TABLE 7.5 - Forest domestic sector (1990)

- TABLE 7.6 - Average quarterly domestic electricity consumption for each parish (1990)
- TABLE 7.7 - Classification of cogeneration/heating network schemes by heat load and suitable plant
- TABLE 7.8 - Present value of energy used at the three (Forest) sites over a ten year period
- TABLE 7.9 - Financial analysis for level 1 delivery
- TABLE 7.10 - Financial analysis for level 2 delivery
- TABLE 7.11 - Parish production/domestic electricity consumption ratio
- TABLE 8.1 - Calculated heat losses of individual rooms of a typical Guernsey home
- TABLE 8.2 - Energy losses of individual rooms of a typical Guernsey home
- TABLE 8.3 - Energy consumption and NPI ratings for the comm/public building in each parish abstraction
- TABLE 8.4 - Energy consumption and NPI ratings for the major tourism end-user in each parish abstraction
- TABLE 8.5 - Energy consumption for the major industrial end-user in each parish abstraction
- TABLE 8.6 - Energy consumption for the major horticulture/vinery end-user in each parish abstraction
- TABLE 8.7 - ICE energy efficiency
- TABLE 8.8 - EV energy efficiency
- TABLE 8.9 - Demographic profile of respondents
- TABLE 8.10 - Delivered energy and primary fuel equivalent by end-use (domestic sector - 1990)
- TABLE 8.11 - Delivered energy and primary fuel equivalent for space/water heating (domestic sector/1990)
- TABLE 8.12 - Delivered energy and primary fuel equivalent for cooking (domestic sector/1990)
- TABLE 8.13 - Delivered energy for the major commercial end-user in each parish abstraction - 1990
- TABLE 8.14 - Delivered energy for the major tourism end-user in each parish abstraction - 1990

- TABLE 8.15 - Delivered energy for the major industrial end-user in each parish abstraction - 1990
- TABLE 8.16 - Delivered energy for the major horticulture/vinery end-user in each parish abstraction/1990
- TABLE 8.17 - Guernsey fuel type/emissions ranking
- TABLE 8.18 - Average amounts of pollutants emitted per unit of end-use energy (U.K. average figures)
- TABLE 8.19 - Guernsey CO2/SO2/NOX emissions (1990)
- TABLE 9.1 - Parish area and population density (1991 census)
- TABLE 9.2 - Estimated total annual parish energy needs in 1990 (not including domestic heat demand)
- TABLE 9.3 - Non-domestic primary energy imports used for process/space/water heating purposes in 1990
- TABLE 9.4 - Corrected total annual parish energy needs in 1990 (not including domestic heat demand)
- TABLE 9.5 - Parish energy balances after all non-domestic heat demands have been met
- TABLE 9.6 - The domestic heat load that is required to maximise 'customer use of waste heat'
- TABLE 9.7 - Parish energy balance after all non-domestic + domestic heat loads are connected
- TABLE 9.8 - Domestic primary energy imports used for space/water heating purposes in 1990
- TABLE 9.9 - Number of end-users not supplied by the heating networks (once waste heat has been maximised)
- TABLE 9.10 - Estimated Island energy balance with all non-domestic + domestic heat loads connected
- TABLE 9.11 - Derived monthly heat averages from cogeneration for the Forest ESCo (H/P ratio = 1.413)
- TABLE 9.12 - Monthly heat average demands for the Forest ESCo
- TABLE 9.13 - Probable annual - minimum ESCo cogeneration heat contribution and maximum ESCo heat demand
- TABLE 9.14 - The most important heat demand sectors for each parish
- TABLE 9.15 - Supplementary heat boiler sizes for each ESCo,

- TABLE 9.16 - Average annual percentage frequency of winds in various velocity bands (m/sec)
- TABLE 9.17 - Energy extracted from a 300 kWe wind turbine (from measurements at the Airport)
- TABLE 9.18 - Offshore wind power contribution to parish ESCos
- TABLE 9.19 - Probable minimum and maximum annual wind energy incomes (300 kWe turbine)
- TABLE 9.20 - Annual electrical energy displacement (Vale cluster)
- TABLE 9.21 - Refuse available for burning on Guernsey
- TABLE 9.22 - Annual electrical energy displacement (St.Sampson cluster)
- TABLE 9.23 - Annual electrical energy displacement (St.Peter Port)
- TABLE 9.24 - Estimated annual energy savings due to the use of renewables
- TABLE 9.25 - Substitution of imported prime fuel, ranked in order of energy saving
- TABLE 9.26 - Ewbank Preece forecast of electricity sales up to the year 2010, by economic sector
- TABLE 9.27 - Electricity sales for the three years immediately after the 1989 Ewbank Preece forecast
- TABLE 9.28 - Annual (1990) parish electricity consumption matrix by economic sector
- TABLE 9.29 - Electric vehicles within each parish ESCo
- TABLE 9.30 - Parish ESCo electricity requirement with EVs
- TABLE 9.31 - Estimated Island energy balance (taken from TABLE 9.10) now with the additional energy service of mobility
- TABLE 10.1 - Hourly loads over the SEB 24 hour peak day period
- TABLE 10.2 - Load duration and loss table
- TABLE 11.1 - Pre-tax evaluation of distributed cogeneration
- TABLE 11.2 - Comparison of the costs of distributed cogeneration and renewable options, when providing one unit of electricity and/or heat

- TABLE 11.3 - Cost of the combined product from distributed cogeneration sources
- TABLE 11.4 - Probable maximum parish diurnal heat energy demands
- TABLE 11.5 - Estimated parish heat network costs (1992 prices)
- TABLE 11.6 - Break-even unit costs for each parish ESCo (including depreciation, but not interest charges)
- TABLE 11.7 - ROI from each parish ESCo with no interest charges and tariffs set the same as centralised charges)
- TABLE 11.8 - ROI (%) from each ESCo with interest rates through the range five to twenty percent

## LIST OF FIGURES

- Figure 1 - The parish of Vale
- Figure 2 - The parish of St.Sampsons
- Figure 3 - The parish of Castel
- Figure 4 - The parish of St.Saviours
- Figure 5 - The parish of St.Peter/Torteval
- Figure 6 - The parish of Forest
- Figure 7 - The parish of St.Andrews
- Figure 8 - The parish of St.Martins
- Figure 9 - The parish of St.Peter Port
- Figure 10 - Guernsey economic growth - reflatd GNP (1990 values)
- Figure 11 - % economic contribution of export sectors to the economy
- Figure 12 - GNP and its components reflatd to 1988 values (1965-1986)
- Figure 13 - Horticultural revenue (1990 values)
- Figure 14 - Coal imports (1950-1990)
- Figure 15 - Fuel oil imports 1950-1990 (HFO + Gas Oil + Kerosene)
- Figure 16 - Energy/capita + GNP/capita (1990 values)
- Figure 17 - The Guernsey rich picture
- Figure 18 - Activity diagram
- Figure 19 - States of Guernsey Energy Management System - Resolution level 1
- Figure 20 - 'Energy Market Analysis' System - Resolution Level 2
- Figure 21 - 'Energy Planning' System - Resolution Level 2
- Figure 22 - 'Regulatory' System - Resolution Level 2
- Figure 23 - 'Energy Planning Review' System - Resolution Level 2

- Figure 24 - Computer model building
- Figure 25 - Primary energy imports (ex. transport) into Guernsey (1960-1990)
- Figure 26 - Fuel oil imports 1977-1990 (HFO + Gas Oil + Kerosene)
- Figure 27 - Transport 1965-1990 (Avgas + Avtur + Motor Spirit)
- Figure 28 - 1990 petroleum product imports
- Figure 29 - Bulk storage capacity for the four petroleum agencies
- Figure 30 - Heavy fuel oil energy flows in 1990
- Figure 31 - Gas Oil, Motor Spirit, Avtur and Avgas energy flows in 1990
- Figure 32 - Kerosene and LPG energy flows in 1990
- Figure 33 - Coal energy flows in 1990
- Figure 34 - Energy flows to economic sectors (1990) with 'overhead'
- Figure 35 - Energy flows to economic sectors (1990) without 'overhead'
- Figure 36 - Domestic sector energy consumption (1990)
- Figure 37 - The trend in domestic electricity demand (1963-1990)
- Figure 38 - Correlation of domestic electricity consumption against GNP
- Figure 39 - Correlation of domestic electricity consumption against population
- Figure 40 - Commercial/tourism/industrial sector energy consumption (1990)
- Figure 41 - The trend in commercial/tourism/industrial electricity demand (1963-1990)
- Figure 42 - Correlation of comm/tourism/indust electricity consumption against average price/unit
- Figure 43 - Correlation of comm/tourism/indust electricity consumption against GNP
- Figure 44 - Correlation of comm/tourism/indust electricity consumption against population

- Figure 45 - Horticulture/vinery sector energy consumption (1990)
- Figure 46 - End-user HFO demand 1977-1990 (including Product 469)
- Figure 47 - General trend in the end-user energy market
- Figure 48 - Transport sector energy consumption (1990)
- Figure 49 - The trend in end-user Motor Spirit demand (1965-1990)
- Figure 50 - Correlation of Motor Spirit consumption against GNP
- Figure 51 - SEB - Fuel energy conversion (net efficiency %)
- Figure 52 - Total number of motor vehicles in use (1950-1990)
- Figure 53 - Vale pareto analysis
- Figure 54 - St.Sampson pareto analysis
- Figure 55 - Castel pareto analysis
- Figure 56 - St.Saviours pareto analysis
- Figure 57 - St.Peter/Torteval pareto analysis
- Figure 58 - Forest pareto analysis
- Figure 59 - St.Andrew pareto analysis
- Figure 60 - St.Martin pareto analysis
- Figure 61 - St.Peter Port pareto analysis
- Figure 62 - Vale abstract - monthly/seasonal electricity consumption 1989/90
- Figure 63 - Vale abstract - daily electricity consumption
- Figure 64 - St.Sampson abstract - monthly/seasonal electricity consumption 1989/90
- Figure 65 - St.Sampson abstract - daily electricity consumption
- Figure 66 - Castel abstract - monthly/seasonal electricity consumption 1989/90
- Figure 67 - Castel abstract - daily electricity consumption
- Figure 68 - St.Saviour abstract - monthly/seasonal electricity consumption 1989/90



- Figure 69 - St.Saviour abstract - daily electricity consumption
- Figure 70 - St.Peter/Torteval abstract - monthly/seasonal electricity consumption 1989/90
- Figure 71 - St.Peter/Torteval abstract - daily electricity consumption
- Figure 72 - Forest abstract - monthly/seasonal electricity consumption 1989/90
- Figure 73 - Forest abstract - daily electricity consumption
- Figure 74 - St.Andrew abstract - monthly/seasonal electricity consumption 1989/90
- Figure 75 - St.Andrew abstract - daily electricity consumption
- Figure 76 - St.Martin abstract - monthly/seasonal electricity consumption 1989/90
- Figure 77 - St.Martin abstract - daily electricity consumption
- Figure 78 - St.Peter Port abstract - monthly/seasonal electricity consumption 1989/90
- Figure 79 - St.Peter Port abstract - daily electricity consumption
- Figure 80 - Heat/electricity supply and demand
- Figure 81 - Guernsey energy model methodology
- Figure 82 - Parish spreadsheet model
- Figure 83 - Two hours of typical demand table (measurements at 15 minute intervals)
- Figure 84 - Guernsey energy model entry screen
- Figure 85 - Parish cluster sub-menu
- Figure 86 - Digitised map of the central area of the parish of Forest
- Figure 87 - Discounted cashflow for energy used at the three (Forest) abstraction sites over a ten year period
- Figure 88 - Energy analysis for the Airport site
- Figure 89 - Financial analysis for the Airport site

- Figure 90 - Seasonal electrical profile for the Forest abstraction
- Figure 91 - Seasonal heat profile for the Forest abstraction
- Figure 92 - Production (electrical) consumption profile for Forest
- Figure 93 - Domestic (electrical) consumption profile for Forest
- Figure 94 - Final parish (Forest) electrical profile
- Figure 95 - Forest energy service delivery modelled on the basis of all available heat energy being sold (ceteris paribus E demand and E supply)
- Figure 96 - Validation of the nine (temperature corrected) final parish profiles
- Figure 97 - Typical Guernsey cottage
- Figure 98 - Visual impact of the centralised power station
- Figure 99 - Cogeneration production
- Figure 100 - Separate (conventional) production
- Figure 101 - Forest ESCo heat requirements
- Figure 102 - Vale ESCo heat requirements
- Figure 103 - St.Sampson ESCo heat requirements
- Figure 104 - Castel ESCo heat requirements
- Figure 105 - St.Saviour ESCo heat requirements
- Figure 106 - St.Peter/Torteval ESCo heat requirements
- Figure 107 - St.Andrew ESCo heat requirement
- Figure 108 - St.Martin ESCo heat requirements
- Figure 109 - St.Peter Port ESCo heat requirements
- Figure 110 - Forest composite (worst case) diurnal winter heat energy scenario
- Figure 111 - Typical 300 kWe wind turbine performance curve
- Figure 112 - QQT of a typical 300 kWe land based (Airport) wind turbine
- Figure 113 - Cumulative probability distribution for land based site

- Figure 114 - Cumulative probability distribution for offshore (+30% wind velocity) site
- Figure 115 - Cumulative probability distribution for offshore (+60% wind velocity) site
- Figure 116 - Land based wind turbine simulation
- Figure 117 - Offshore (+30%) wind turbine simulation
- Figure 118 - Offshore (+60%) wind turbine simulation
- Figure 119 - Bordeaux landfill gas analysis
- Figure 120 - Vale ESCo/heating network
- Figure 121 - St.Sampson ESCo/heating network
- Figure 122 - Castel ESCo/heating network
- Figure 123 - St.Saviour ESCo/heating network
- Figure 124 - St.Peter/Torteval ESCo/heating network
- Figure 125 - St.Andrew ESCo/heating network
- Figure 126 - St.Martin ESCo/heating network
- Figure 127 - St.Peter Port ESCo/heating network
- Figure 128 - Advisory and Finance annual planning round
- Figure 129 - Guernsey electricity network
- Figure 130 - States of Guernsey Electricity Board - peak day 7 February 1991
- Figure 131 - Discounted cashflow for wind generation
- Figure 132 - NPV over a discount rate range of 5%-20% (fuel price 14.9p/Litre)
- Figure 133 - NPV over a discount rate range of 5%-20% (fuel price 14.9p DC and 7p CG /Litre)
- Figure 134 - NPV over a fuel price range of 5p-60p/Litre (discount rate 15%)
- Figure 135 - NPV over a fuel price range of 5p-60p/Litre (discount rate 15%)
- Figure 136 - Simple hot water heating network
- Figure 137 - Comparison of centralised unit price with average ESCo break-even unit cost
- Figure 138 - Conflicting pressures on parish ESCos

- Figure 139 - Values of the premium required to take the benefit of reduced oil imports into account
- Figure 140 - Resolution level 3 'Energy Market Analysis' sub-system models
- Figure 141 - Resolution level 3 'Energy Planning' sub-system models
- Figure 142 - Resolution level 3 'Regulatory' sub-system models
- Figure 143 - Resolution level 3 'Energy Planning Review' sub-system models
- Figure 144 - Vale - Alliance cash and carry supermarket diurnal electricity profile
- Figure 145 - Vale - Peninsula Hotel diurnal electricity profile
- Figure 146 - Vale - Juas Quarry diurnal electricity profile
- Figure 147 - Vale - Vingtaine vinery diurnal electricity profile
- Figure 148 - St.Sampson - States Prison diurnal electricity profile
- Figure 149 - St.Sampson - Les Vardes Quarry diurnal electricity profile
- Figure 150 - St.Sampson - Kenilworth vinery diurnal electricity profile
- Figure 151 - Castel - King Edward VII Hospital diurnal electricity profile
- Figure 152 - Castel - Hougue du Pommier Hotel diurnal electricity profile
- Figure 153 - Castel - States Water (Kings Mills) diurnal electricity profile
- Figure 154 - St.Saviours - Mont Variouf School diurnal electricity profile
- Figure 155 - St.Saviours - Atlantique Hotel diurnal electricity profile
- Figure 156 - St.Saviours - States Water (dam/reservoir) diurnal electricity profile
- Figure 157 - St.Saviours - Les Mourants vinery diurnal electricity profile

- Figure 158 - St.P/Torteval - Le Riche Stores diurnal  
electricity profile
- Figure 159 - St.P/Torteval - Imperial Hotel diurnal  
electricity profile
- Figure 160 - St.P/Torteval - Bader Roses diurnal electricity  
profile
- Figure 161 - Forest - States Airport (passenger terminal)  
diurnal electricity profile
- Figure 162 - Forest - States Airport (technical block)  
diurnal electricity profile
- Figure 163 - Forest - Mallard Country Club diurnal  
electricity profile
- Figure 164 - Forest - Sovereign Flowers diurnal electricity  
profile
- Figure 165 - St.Andrews - Grammar School (service 1) diurnal  
electricity profile
- Figure 166 - St.Andrews - Grammar School (service 2) diurnal  
electricity profile
- Figure 167 - St.Andrews - States Dairy (service 1) diurnal  
electricity profile
- Figure 168 - St.Andrews - States Dairy (service 2) diurnal  
electricity profile
- Figure 169 - St.Andrews - J.Angenent Roses diurnal  
electricity profile
- Figure 170 - St.Martin - Princess Elizabeth Hospital  
(service 1) diurnal electricity profile
- Figure 171 - St.Martin - Princess Elizabeth Hospital  
(service 2) diurnal electricity profile
- Figure 172 - St.Martin - St.Margarets Lodge Hotel diurnal  
electricity profile
- Figure 173 - St.Martin - Bali-Hai vinery diurnal electricity  
profile
- Figure 174 - St.P.Port - Beau Sejour (service 1) diurnal  
electricity profile
- Figure 175 - St.P.Port - Beau Sejour (service 2) diurnal  
electricity profile
- Figure 176 - St.P.Port - St.Pierre Park Hotel diurnal  
electricity profile

- Figure 177 - St.P.Port - Intersurgical (service 1) diurnal electricity profile
- Figure 178 - St.P.Port - Intersurgical (service 2) diurnal electricity profile
- Figure 179 - St.P.Port - Rammee Roses diurnal electricity profile
- Figure 180 - Typical hotel diurnal electricity demand QQT profile
- Figure 181 - Typical hotel seasonal electricity QQT profile
- Figure 182 - Typical vinery diurnal electricity demand QQT profile
- Figure 183 - Typical vinery seasonal electricity QQT profile
- Figure 184 - Diurnal electricity demand profiles for unrestricted domestic (winter weekday) annual consumption ranges (42F)
- Figure 185 - Capital/installation costs of cogeneration (diesel based) plant
- Figure 186 - States Airport - electricity demand (22-23 November 1990)
- Figure 187 - States Airport - electricity demand (seasonal)
- Figure 188 - States Airport - heat demand (seasonal)
- Figure 189 - Sovereign Flowers - electricity demand (26-27 September 1991)
- Figure 190 - Sovereign Flowers - electricity demand (seasonal)
- Figure 191 - Sovereign Flowers - heat demand (seasonal)
- Figure 192 - Mallard Country Club - electricity demand (31-1 June 1991)
- Figure 193 - Mallard Country Club - electricity demand (seasonal)
- Figure 194 - Mallard Country Club - heat demand (seasonal)
- Figure 195 - Estimated electrical M.D. for the parish of Vale (Temp. corrected to - 4.7 C)
- Figure 196 - Estimated electrical M.D. for the parish of St.Sampson (Temp. corr. to - 4.7 C)
- Figure 197 - Estimated electrical M.D. for the parish of Castel (Temp. corrected to - 4.7 C)

- Figure 198 - Estimated electrical M.D. for the parish of St.Saviours (Temp. corr. to - 4.7 C)
- Figure 199 - Estimated electrical M.D. for the parish of St.P/Torteval (Temp. corr. to - 4.7 C)
- Figure 200 - Estimated electrical M.D. for the parish of St.Andrews (Temp. corr. to - 4.7 C)
- Figure 201 - Estimated electrical M.D. for the parish of St.Martins (Temp. corr. to - 4.7 C)
- Figure 202 - Estimated electrical M.D. for the parish of St.Peter.Port (Temp. corr. to - 4.7 C)
- Figure 203 - Typical VINERY diurnal heat profile
- Figure 204 - Typical DOMESTIC diurnal heat profile
- Figure 205 - Typical diurnal heat profile at Princess Elizabeth HOSPITAL
- Figure 206 - Typical diurnal heat profile at BEAU SEJOUR
- Figure 207 - Composite Vale (worst case) diurnal winter heat energy scenario
- Figure 208 - Composite St.Sampsons (worst case) diurnal winter heat energy scenario
- Figure 209 - Composite Castel (worst case) diurnal winter heat energy scenario
- Figure 210 - Composite St.Saviour (worst case) diurnal winter heat energy scenario
- Figure 211 - Composite St.Peter/Torteval (worst case) diurnal winter heat energy scenario
- Figure 212 - Composite St.Andrew (worst case) diurnal winter heat energy scenario
- Figure 213 - Composite St.Martin (worst case) diurnal winter heat energy scenario
- Figure 214 - Composite St.Peter Port (worst case) diurnal winter heat energy scenario

### Acknowledgements

I am grateful to the States of Guernsey Education Council for sponsoring this research and to the General Manager of the States Electricity Board (now known as Guernsey Electricity) for access to reliable data sources. The like of which has not been so readily available to academic researchers and other individual practitioners in the energy field.

My thanks to Dr Keith Jacques for his guidance, constructive comment and encouragement; also Gill Mould and John Bowers. To Katie Black, Paul Brown, Mike Larocque and Dave Sarchet for their research assistance; and Jeanette, Kathryn and Louise for their time and support.



## ABSTRACT

There is currently no strategic energy conservation management on the island of Guernsey, nor may it be adequate to leave energy management entirely to market forces. Market mechanisms of themselves may not be adequate to balance the intrinsically conflicting objectives of obtaining the cheapest possible energy, ensure security of supply, reduce the risks associated with over-dependence on particular energy sources (such as petroleum products), whilst protecting the environment. Properly formed data sets, together with time-based capital budgeting, are necessary prerequisites for balanced political choice.

The thesis deals with the central issues of strategy by use of a soft systems methodology. It develops the proposition that energy needs for communities, or 'clusters' of demand, might be better met and matched by taking local needs for energy and matching them to locally, parish based, generated supplies. This approach runs counter to much current public energy policy in relation to utilities and supply-demand relationships.

Quality, Quantity and Timing (QQT) computer based models are developed for each parish on Guernsey which reflect diurnal/seasonal patterns of demand and explain

how variability of demand on various time scales may influence supply technology choices. Parish energy sources are compared on a least-cost basis and a simulation model is used to take into account the variability in the supply potential of alternative renewable sources of energy, and its relationship to variability of demand (as exposed by QQT modelling).

The work described uses computer models based upon SuperCalc 5 advanced spreadsheet modelling techniques, dBASE III Plus database/programming language and compiled under Clipper. A TurboPascal simulation programme was also considered but ultimately rejected in the present context.

As well as dealing with the central issues of strategy, and the tactics for achieving them, the thesis analyses the prospect that decentralisation of the power and energy base (through distributed cogeneration) could be a much better strategy to follow for an island such as Guernsey.

One outcome of the soft system and simulation modelling approaches was a proposed formal 'States of Guernsey Energy Management System' to provide a mobilising strategy and an environment for market forces to operate within. This focuses on the energy service requirements of each parish and attempts to answer such questions as:

"do we expand the present centralised Island supply of fuels and electricity, or do we instead use less fossil fuels to meet the energy services we want by other means, at lower cost ?".

The fundamental proposition of the thesis is that much improved means exist for the efficient utilisation of important resources (energy, capital, manpower) within Guernsey and importantly, a wide range of other well populated 'energy clusters'.

## CHAPTER 1

### INTRODUCTION

The island that is at the centre of this thesis is the westernmost of the archipelago of the English Channel. The island lies in the shallow rectangular bay formed by the west coast of the Contentin peninsula of lower Normandy and the north coast of Brittany, in a position that rather withdraws it from the main stream of traffic passing up the English Channel. Nearer to France than to England, it has, by an accident of history, been linked with the latter country for more than seven hundred years.

#### 1.1 The island of Guernsey

The island of Guernsey has kept up an individuality of its own through the centuries. Geographically French, politically English it differs from each of the neighbouring mainlands. The fact of Guernsey belonging to England, which is to be explained chiefly by political history, has been important. Although so close to France, the economic orientation, particularly in the past hundred years has been entirely towards England. The Island's communications, its present day language and its spiritual values are from England.

When the climate was recovering from the Ice Age Guernsey may have been already an island (the rocks contain

no fossils and therefore cannot be dated<sup>1</sup>). If Guernsey was already an island, it was a tangle of bushes and bracken. There were extensive woodlands of which only the names remain. To early man the valleys gave water for drinking and wood for fuel<sup>2</sup>.

We can take Guernsey to be a roughly triangular island, right-angled in the south-east, its southern and eastern coasts each eleven km in length, the area roughly estimated at 65 square km. It is highest in the south, where part of it is raised as a small plateau just over 90 m above sea-level. The Island presents an even skyline with gentle contours. The southern plateau (high parishes) and the northern plain (low parishes) differ in height. The dangers of the coast are reflected in the sailing distances; to clear all dangers from the south coast a minimum distance of 1.2 km is recommended, but off the west coast this distance is increased to 4.8 km.

With the advance of time food was to be had by trapping or hunting animals in the woods. Shore animals such as limpets, ormers, fish and crabs were caught. The gathering of seaweed (or vraic) for manuring the land and when dried for fuel. For centuries then, Guernsey lived by farming and fishing; farming, and later the 'growing' industry and stone quarrying have a close connection with the geographical

1. See Barry, Wm, 1815, 'The history of the island of Guernsey, from the remotest period of antiquity to the year 1814'.

2. See Warren, J.P, 1926, 'Our own island'.

environment which have completely transformed the appearance of the Island.

**Growing:**

Greenhouses were built all over the Island, particularly in the northern parishes of the Vale and St. Sampsons. The reason being that a warm sandy soil is to be found in these two parishes and as farming was not so developed in these parishes the land was cheaper. Wind turbines were used widely for pumping water from boreholes for greenhouses, being seen nearly everywhere.

In 1861, for the first time, Guernsey had a steamer arriving daily during the summer months, and four times a week in winter. Within ten years of that date the growing industry became firmly established, the English connection being instrumental in securing the required markets<sup>1</sup>. Coal became the first primary energy imports into the Island, mainly for greenhouse heating purposes.

Most of the greenhouses were artificially heated, enabling fruit to be put on the market very early in the year when it commanded the highest prices. Up to about 1900, table grapes were the chief product for export from the greenhouses, or vineries as they were called.

**Stone quarrying:**

There are geological differences between the north and

1. See Demangeon, A, 1927, 'Les Isles Britanniques, Vol 1 of the Geographie Universelle, Publie par vidal de la blache et L.Gallois'.

the south of the Island. The fact that nearly all the quarries are situated in the northern part of the Island emphasises the distinction between the rocks. It is in the north of the Island that large exposures of diorite occur, popularly known as 'blue granite' and it is here that the stone industry has been centred for more than a hundred years. It was mainly due to the stone industry that the northern parishes of the Vale and St.Sampsons greatly increased in population in the last century.

It is here where an electric power station was built to supply the quarry industry (ie. location specific).

This small granitic Island is the home of a prosperous community of 58,867 people (1991 census), 906 people to the square km.

Others<sup>1</sup> have commented on the density of the population of the Island. Guernsey being a notable example of the fact that some islands "attract, preserve, multiply and concentrate population". It is this particular class of small islands, with high population densities, that the present work is going to be concerned with.

## 1.2 Island government

Guernsey lays claim to a series of laws, customs, dues, rights, privileges, charters, ordinances, enactments, liberties and exemptions which place the Channel Islands in an altogether different position to that of any part of the

1. For example Semple, P.C, 'Influences of geographic environment'.

United Kingdom.

Constitutional history dates from Norman times; the Channel Islands form part of the Duchy of Normandy and linked with England when William I ascended the English throne<sup>1</sup>. Laws have been constructed upon a feudal framework.

Local affairs are conducted by the parishes which coincide with those established originally by the Church. Law and order in each parish is preserved by two officials known as Constables. The actual controlling body, representing and elected by the parishioners, is the Douzaine. Douzeniers are elected for a period of six years.

The internal government of the Island as a whole is conducted by the States. This body exercises jurisdiction over the Bailiwick of Guernsey, which includes also the smaller islands (Alderney, Sark and Herm), though both Alderney and Sark have a greater measure of independence. Alderney has its own parliament; Sark, with about 600 people has an hereditary ruler and a government (Chief Pleas).

It is surprising that the States of Guernsey can exist and act independently from the British Parliament, but they do.

Insular legislations are of two main types and each may affect our approach to energy management:-

1. See Tupper, P.B, 1876, 'The history of Guernsey and its Bailiwick'.



(1) Laws - a law originates in the passing by the States of a 'Projet de Loi'.

A Projet de Loi is the implementation of proposals laid before the States by a committee(s) or by at least seven members of the States (ie. a Requete). It has no force of law until it has been transmitted by the Bailiff through the Lieutenant Governor, accompanied by a report by H.M. Procureur to the U.K mainland. Her Majesty the Queen is then advised on the Projet de Loi by the Privy Council.

The Royal sanction ratifying the Projet de Loi is contained in an 'Order of Her Majesty in Council' to which is annexed the Projet de Loi, which then becomes law.

(2) Ordinances - are the means by which the States exercise legislative power. This power to make ordinances does not allow the imposition of legislation, cannot alter a law and cannot make rules of procedure in the Royal Court or lower courts.

The States have the following powers:-

(1) To raise money by way of taxation, as provided by legislation (ie. under the Income Tax (Guernsey) Law, 1975).

(2) To decide how the money raised by taxation shall be spent (ie. running schools/hospitals, capital projects etc).

(3) To approve regulations (made by committees of the States); to pass ordinances and to approve draft laws or Projet de Loi.

(4) To direct individual committees on specific tasks.

When the assembly meets it is known as 'The States of Deliberation' and meetings are convened by the Bailiff in printed notices known as Billets d'Etat.

The States delegate day to day responsibility for each aspect of Government to individual committees, each of which is responsible directly to the States. The Advisory and Finance Committee co-ordinate the work of the States. All States members sit on one or more committees; a member may thus be regarded as part of the 'Government' so far as his committee is concerned, but is free to oppose the proposals of any other committee.

For comprehensive references, particularly on Guernsey, see Ansted, D.T or Barre, O, etc<sup>1</sup>.

### 1.3 Guernsey today

Guernsey is a dependent territory of the U.K. and has the following position in relation to the European Union:-

1. Ansted, D.T et al, 1893, 'The Channel Islands'.
- Barre, O, 1905, 'Origines Tectoniques du Golfe de St.Malo'.
- Bolland, H, 1904, 'Les Iles de la Manche'.
- Carey, E, 1904, 'The Channel Islands'.
- Dacey, T, 1777, 'An historical account of the island of Guernsey'.
- Durand, R, 1932, 'Guernsey, present and past'.
- Duncan, J, 1841, 'The history of Guernsey'.

(1) Constitutional position:

"The Bailiwick is an appendage of the Crown associated with the U.K. and the Commonwealth through the Sovereign successor to the Dukes of Normandy and over which the Sovereign in Council exercises supreme legislative and Judicial power"<sup>1</sup>.

(2) Legal position:

Guernsey is not a member state of the EU nor an associate member. The relationship is a 'special relationship' set out in 'Protocol 3' to the Treaty of Accession of the U.K. to the EU<sup>2</sup>.

The Island is within the Common Customs Area and as such enjoys access to EEU countries for physical exports (without tariff barriers). It is exempt from the requirements to harmonise legislation, taxation and energy directives<sup>3</sup>.

**People:**

The Island today is a scene of widespread urban and suburban development, interspersed with greenhouses. In many parts the appearance is one of almost continuous development.

The population has already reached more than 58,000;

1. Billet d'Etat VII of 1967, Appendix p.10.

2. Billet d'Etat, 14 July 1988.

3. See Advisory and Finance Committee, 1992, 'Guernsey the European Community and 1992'.

all of which must live, work, shop and pursue their leisure activities largely within the confines of the Island.

**Economy:**

The economic profile of the Island is changing, with the finance sector growing in importance<sup>1</sup> and tourism remaining the second most important source of revenue; horticulture has declined principally due to the two oil shocks.

Guernsey was greatly affected by the 1973 and 1979 fuel crisis, particularly the horticulture industry. As a consequence of this the industry shrank in size; by 1983 it was half what it had been ten years earlier.

**Transport:**

St. Peter Port harbour has facilities for handling both cargo and passenger traffic. St. Sampson's harbour in the north of the Island handles the importation of all of Guernsey's primary energy imports (oil products, LPG and coal) as well as heavy cargo. There are regular car ferries between the U.K. mainland throughout the year, with frequent hydrofoil sailings to the U.K. and France.

The Island has modern airport facilities and handles short-haul aircraft with regular flights to London's

1. Low taxation is at the heart of the development of Guernsey as an international finance centre. There is no capital taxation and the standard and maximum rate of income tax has remained at 20% since 1960 (the Island is in monetary union with the U.K.). There are more than 300 banks, insurance and investment houses.

Heathrow and Gatwick airports.

**The Media:**

The U.K. daily newspapers are available on the morning of publication and the Island has its own daily newspaper, 'The Guernsey Evening Press' (GEP).

The Island receives BBC radio and television and commercial television.

**Culture:**

The Islanders have always played their part in the British Empire and during the first world war many volunteers from the local militias served in both the British and French armies.

During the second world war the Island was occupied by the Germans from 1940 to 1945 and legacies of this occupation still remain.

**1.4 Parish energy flows**

To establish Guernsey's scale of existence, in round figures, the Island's population is one thousandth that of the United Kingdom (the U.K. accounts for about 1% of the world's population). It's population density is about six times that of the U.K..

The beginning of generation of power in Guernsey on a centralised scale is only a comparatively recent development<sup>1</sup> (historically, the supply of heat and light was

1. The physical scale of very small islands precludes power generation of GWe scale.

entirely a local matter). The parish has a definition that is 'social' as well as geographic and it is an area where people know each other (at least slightly) and treat each other as neighbours. Any movement towards the localised generation and supply of power and heat could well be regarded as a return to this situation.

Energy flows (electricity, oil products, LPG, coal, sewage and solid waste) within each of the Guernsey parishes are to some extent determined by their populations. The character and geography of each of the parishes are now briefly described.

#### **VALE**

The Vale and St.Sampsons are the low-lying parishes of northern Guernsey. This part of the Island is a granite lowland with occasional hillocks (or hougues) where granite was quarried for local building as well as for export. Because of the quarry trade a power station was built here and this became the centralised electricity production site for the Island to the present day.

Older maps of Guernsey show the Clos du Valle as an island cut off at high tide by the sea known as the Braye du Valle, stretching from what is now St.Sampson's harbour across to Grand Havre.

The parish is divided into two unequal parts, the detached portion has a western sea coast, Figure 1.

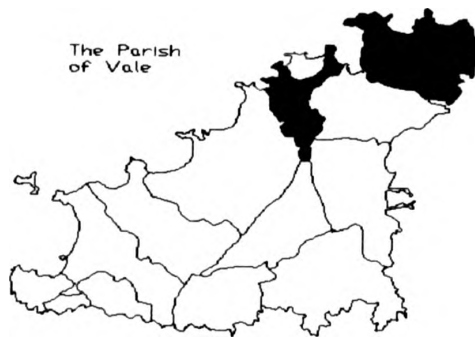

Domestic energy  
<sup>1</sup>  
 end-users - 3,406  
 Population <sup>2</sup> - 9,530

Figure 1

#### ST. SAMPSONS

The land area of St.Sampsons is less than the Vale and is again divided into two unequal parts, Figure 2. The tidal harbour of St.Sampsons is a natural opening in the coast and a haven for ships since the remotest times. It was here some 14 centuries ago that St.Sampson set foot on the Island (Delancey Park in St.Sampsons was once dominated by a large windmill known as Les Monts).



Domestic energy  
 end-users - 2,999  
 Population - 8,045

Figure 2

1. Obtained from the States Electricity Board's billing database (1990).

2. 1991 census.

### CASTEL

The Castel has the largest area of the ten parishes, Figure 3, and is compact in shape. The rocks and reefs of the foreshore are of red granite found only in this restricted area.

Through this parish can be traced the lower part of the largest stream system in Guernsey. The Talbot Valley being the natural course of a stream coming from St. Andrews running down to the beach at Vazon (three water mills operated in the stream; Moulin de Haut, de Milieu and de Bas).



Domestic energy  
end-users - 3,046

Population - 9,068

Figure 3

### ST.SAVIOURS

More than two-thirds of St.Saviours is upland reaching to over 90 m above sea level, Figure 4. One of the major features of the parish is the States Water Board Dam and reservoir which can hold some 241,000,000 gallons of water.

On the heights of Mont Saint was a windmill which was erected about 1830, where stone brought from Sussex and the Isle of Sheppey was ground and used in the making of cement.



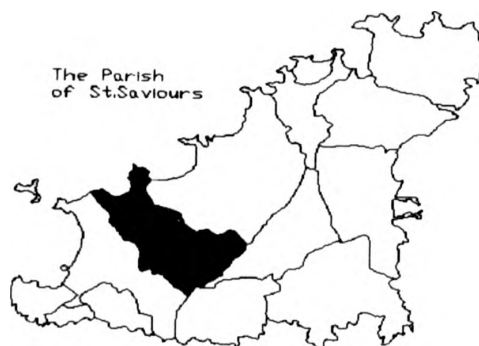

Domestic energy  
end-users - 858

Population - 2,419

Figure 4

#### ST. PETERS/TORTEVAL

The two parishes of St.Peter and Torteval cut into and divide each other, Figure 5. The detached portion of St.Peters is the island of Lihou, the central part of which is over 15 m above sea level. A causeway gives access to Lihou at low water only, and in the last century was the recognised place for the gathering and collecting of vraic for use as fuel and fertiliser.

The western half of Torteval is Pleinmont, the first to be buffeted by the winds and storms from the Atlantic Ocean.



Domestic energy  
end-users - St.P - 742  
Tort - 371

Population  
St.P - 2,242  
Tort - 976

Figure 5

### FOREST

Forest is a small parish comprising some of the highest land in Guernsey, Figure 6, the greater part of which is more than 90 m above sea level.

The rigid line of the cliffs is broken by inlets and headlands which at one time was common land, but about a century ago it was divided among the parishioners so that every one had a share.



Domestic energy  
end-users - 487

Population - 1,386

Figure 6

### ST.ANDREWS

St.Andrews lies centrally inland, roughly triangular in shape, and has no coast line, Figure 7.

Despite the spread of greenhouses and housing estates some of the best farms are to be found. The parish is very fertile and is one of the leading parishes for grassland, and has the greatest number of cattle in proportion to its size.



Domestic energy  
end-users - 795

Population - 2,357

Figure 7

**ST. MARTINS**

St. Martin's coast reaches from Fermain Bay to Petit Bot and is well known for its coastline, and more popular than those of other parts of the Island, Figure 8. Because of this and its nearness to the Town, St. Martins has become a residential and suburban parish.

Much of the parish is over 90 m above sea level.



Domestic energy  
end-users - 2,176

Population - 6,082

Figure 8

### ST.PETER PORT

Of the 10 parishes into which the Island is divided that of St.Peter Port is situated along the eastern coast with a natural harbour, and well sheltered from west winds and south-westerly gales, Figure 9.

St.Peter Port is the centre of Government and has a daily influx of workers to shops and offices; out of the main town the parish is suburban and residential.



Figure 9

#### 1.5 The energy problem

It would be impossible to address the Island energy problem without calling to mind those dramatic pictures of the "Braer<sup>1</sup>", the oil tanker which ran aground on the coastline of the Shetland archipelago recently. Few examples could illustrate more explicitly the extreme fragility of

1. See Carty, P, October 1993, Accountancy, 'troubled water'.  
The Braer disaster followed close on the heels of the wreck of the Greek combination carrier 'Aegean Sea' (Spanish port of Corunna), where a 607,000 barrel cargo of oil polluted 93 miles of coast.

island environments and their economies, faced with energy supply/demand choices. Fortunately this particular example seems to have left very little 'damage'.

It is now more than twenty five years ago that the 'Torrey Canyon' sank between Cornwall and the Isles of Scilly. Large quantities of oil came onto the Guernsey beaches, some of which is still held in one of the Island's disused quarries after the massive clean-up operation.

Even after such a disaster and the later uncertainty about an energy-deficient world economy in the 1970s, the justifications for a strategic energy conservation programme have been completely absent on the Island. This is also the case on the U.K. mainland, where the context has been essentially a 'micro-economic' one (ie. related to marginal improvements to households, company profitability etc<sup>1</sup>). It is important therefore for someone to address these strategic issues, which may have significant energy implications, particularly for very small (densely populated) islands such as Guernsey.

There appear to be four main areas of concern:-

(1) A sub-optimal energy balance seems to exist with significant so-called waste heat losses, particularly from centralised electricity generation.

(2) Responsibilities for energy matters appear to be

1. See Cheshire, J, 1992, 'The pace of change', for a more detailed discussion.

muddled and obscure, reflected in the present institutional structure<sup>1</sup>. With various piecemeal decisions, announcements of intentions and plans, which together form an approach to energy management of a sort, but it is not a holistic approach, which is what is required.

(3) A perception of a lack of political accountability and control. An arrangement that may suit Island politicians who tend not to have any policies but who have an opinion on everything.

(4) Concern regarding the possibility of inappropriate long-term energy supply choices, based upon a centralised view of energy supply.

We will show that using these centralised methods of the past have clearly not provided optimal energy usage.

The traditional (centralised) approach to energy planning is questioned in the present work in relation to the importance of energy planning at a more local level (from the demand side [end-user] rather than the supply side). Each parish is very different in terms of their energy needs (see Section 1.4); the current centralised approach minimises these differences by simply ignoring them.

1. See Guernsey Evening Press, 14 September 1990, 'Friends of the Earth want an Island energy policy'.

Others<sup>1</sup> have recognised the importance of this localised level. A joint study carried out on the U.K. mainland by the North Western Electricity Board (NORWEB) and the Energy Technology Support Unit (ETSU) for example (1989) indicated that their study was:

"Important in leading us to think about a more fundamental and largely unexplored issue - the merits of local versus centralised power generation. The study suggests that we ought now to look more closely at both the generation and use of energy at a much more localised level. Energy supply could become much more of a community issue than it has been hitherto".

Power generation on very small islands is usually achieved by diesel engine power plants, sited at one centralised location on the island. The concept of waste heat recovery and cogeneration is not really addressed<sup>2</sup>.

The present work argues that by dispersing the power and energy base and making use of electricity and also heat it may result in greater energy efficiency and (important to very small islands) a significant reduction in petroleum product imports. But in order to test this, new methods of analysis are required.

1. See The Quarterly Journal of Renewable Energy, Issue 9, Autumn 1989, 'Joint Study by Norweb and ETSU'.
2. Diesel power stations traditionally operated in their 'electricity only' mode. Which inevitably results in the evolution of large quantities of low grade heat, which is normally discharged to the environment in cooling towers.

One of the major problems facing the developed and undeveloped world is that resources of fossil fuels may have a finite life. There are many 'guesstimates' of this life, ranging from fifty years in the case of oil to four hundred years in the case of coal<sup>1</sup>. A renewed tightening of the international oil and energy markets will therefore remove the safeguard presently provided by the current surplus of capacity and may pose the main threat to Guernsey's energy security in the future. We will show that this is only one of a number of good reasons for small island communities to consider reducing their primary energy imports<sup>2</sup>.

The approach we use is not the usual one based on either a 'soft energy path'<sup>3</sup> or a 'hard energy path'<sup>4</sup>, but a more original contribution that particularly questions the loss of large amounts of heat energy presently rejected by centralised electricity production on the Island.

#### 1.6 Holistic energy conservation

Energy conservation is usually associated with demand

1. See Hedley, D, 1986, 'World energy: the facts and the future' for example.
2. Others are dwindling resources (the fuel we are wasting is part of a once-only endowment of our planet); reduced dependence on imported oil; energy price stability; concern for the environment etc.
3. See Lovins, A.B, 1977, 'Soft energy paths: Towards a durable peace'. Based upon energy technologies that are sustainable, benign etc.
4. Hard energy path - referred to as business as usual.

See Hafele, W, 1981, 'Energy in a finite world' with regard to the hard-soft controversy (pp 755-767).



side activities, but very little attention has been given to a more strategic, holistic<sup>1</sup> assessment of energy conservation on Guernsey, which may produce new data/information and new conclusions.

Others<sup>2</sup> have considered in detail modern applied energy conservation at the business level, but within the present work we consider the two other levels, namely:-

(1) The global level

One of the most fundamental global problems is the environment; 'green' issues are being put ever higher on the political agenda throughout the world. The need is to nurture the environment by good energy management; systemic energy management can help here by making sensible and prudent use of existing primary energy a priority.

(2) The Island level

The less energy the Island needs, the greater the security and the less vulnerable the Island is to circumstances outside of its control (such as sudden price rises and scarcity of supply).

The importation of all primary energy is reflected as a drain on economic resources. The effects of increases in oil prices, particularly during the two oil shocks in 1973 and

1. Not reflecting a partisan approach (as seen from the viewpoint of a centralised energy supplier for example). Admirable as such viewpoints may be they do little to achieve a holistic perspective.

2. For example Jacques, J.K, Lesourd, J.B and Ruiz, J.M, 1988, 'Modern applied energy conservation'.

1979, have been seen on Island income. Any savings in the use of imported energy, large or small, should therefore be welcomed.

#### **Waste heat**

A working group on the U.K. mainland (appointed by the Watt Committee on Energy) have recently been considering the problem of making more use of this so-called waste heat<sup>1</sup>. Noting that vast quantities of heat at relatively low temperatures finds its way to atmosphere (the group describe 'low temperature' as about 250 C or less). Concluding that to make more use of so-called waste heat will involve no new discoveries; the technologies already exist and have been proven.

The group went on to suggest that the factors which limit the application of these technologies are twofold:-  
(1) A primary factor must be the way in which investment projects are ranked, and the ranking which is then given to low temperature projects.

(2) A probable second factor is that the opportunities for making use of low temperature heat is not always well known and may be missed by default.

Both these considerations have therefore to be part of our modelling process.

Presently there is no forum within the Island for such

1. See Crook, A.W et al, 1991, 'Profiting from low-grade heat'.

ranking to occur<sup>1</sup> and no-one has adequately identified the opportunities on the Island for making use of such low grade heat. We will show that there is a need for a formal energy management forum to do this.

The only States trading body concerned with energy matters is the Electricity Board (SEB) which has been able to carry out its mandate (constituted on 25 November 1933) for many years, with minimum supervision and interference from the States. The responsibilities placed upon the SEB are restricted to the provision of electricity to the Island (the SEB are not mandated to consider an overall energy strategy<sup>2</sup>).

The overall energy conversion efficiency of the undertaking is low; 41.3% efficiency is reached at times. The centralised power station rejects a substantial amount of heat energy as exhaust gas up the chimneys, and to cooling water towers which in turn discharge to the environment by evaporation of water. A new recently sanctioned power station ('D'), again on the same site in the Vale, has been so designed as not to use cooling towers due to complaints from nearby residents regarding clouds of steam being dispersed over the Bridge shopping area.

Radiators are to be mounted on the roof (160 kWe per

1. This is also usually the case in most other small island situations.
2. Even though electricity production does have an important role to play in setting future Island energy directions.

engine) in order to discharge this waste heat higher into the atmosphere<sup>1</sup>. The auxiliary power required for this new (large) slow-speed diesel generator is thus 433 kWe, significantly higher than the standing load requirements of any of the other existing slow-speed engines. This is not energy conservation; it is almost wilful profligacy.

Electricity sales have been forecast<sup>2</sup> to increase by 73% over the next twenty years. With centralised electricity production, this potentially represents an even greater loss of heat energy than presently occurs and has to be seriously questioned.

An independent consultant's report<sup>3</sup>, appointed by the States to inquire into the workings and level of efficiency of the SEB years ago (1982), suggested that the Board should at that time pursue ways of using their waste heat. The Board's problem however, is that their centralised generation is located in the wrong place to make use of it.

#### **Thermodynamic matching**

To optimise efficiency, primary energy should under-go as few changes of state as possible, and be used near to the

1. See Billet d'Etat XVI, 26 September 1990, 'Electricity generating capacity'
2. See SEB News, Spring 1989.
3. See Guernsey Evening Press, 6 February 1982, 'Electricity report is welcomed by Board President'.

end-user to minimise transmission losses<sup>1</sup>.

If end-users require high quality energy forms, such as electricity, ways need to be found of usefully employing the low grade waste energy released in the conversion process. But this can only really be done by dispersing the location of such cogeneration plant and increasing the efficiency through heating networks.

An important element in any conservation strategy may therefore be the thermodynamic matching of the Quality (Q) of the energy source with the Quality (Q) of the energy demand. Frequently the amount of energy consumed in various operations is far greater than is necessary and does not utilise the available work ('free energy') effectively.

Heat, mostly at low temperature, but often generated from fossil fuel or electricity, is used on the Island (but such fuels are capable of providing heat at temperatures much higher than required). We will show that the heat derived from distributed waste heat sources may go a long way to matching the quality of most of these low grade heat energy demands on Guernsey, but this needs to be tested.

#### **1.7 A wider view is required**

The Island needs to have a much wider view of energy provision than just the provision of electricity; it is an

1. See for example Twidell, J.W and Pinney, A.A, 1987, 'The quality and exergy of energy systems, using conventional and renewable resources'

emphasis on energy we need, not electricity<sup>1</sup>.

We will show that traditional (centralised) energy planning methods are just not appropriate for distributed cogeneration applications. Distributed cogeneration fundamentally changes the way in which energy planning is carried out.

Centralised power generation planning focuses on finding the least-cost bulk power generation option to meet a given demand. This approach does not account for the full array of costs associated with the delivery of that power to the final end-user who will use it. Nor does it account for the utilisation of the associated so-called waste heat.

Large generating units within centralised power stations do have some real advantages, though advantages are often subjective. The SEB are responsible for selecting large, slow-speed, two-stroke diesel engines within their centralised power station in the Vale (currently the only U.K. application). Combined cycle (electricity only) plant is essentially large-scale for very small islands such as Guernsey, whereas diesels do provide more appropriate small-scale matching.

The electricity industry is often cited as a classic

1. See also Jenkins, N, 1990, 'It is energy we need not electricity'.

example of economies of scale. The paper by Tombs<sup>1</sup> for example typically represents the electricity supply industry's myopic view, which conveniently does not address the 'disadvantages' of large generating units<sup>2</sup>.

Research at the Polytechnic of the South Bank<sup>3</sup> has examined the use of these large slow-speed diesels in base load electricity generation roles<sup>4</sup>.

Slow-speed diesels are primarily used for tanker ship propulsion (not base load electricity generation) and as such are designed for continuous operation, not for frequent starting and stopping.

They have an attraction in terms of their higher efficiency, compared with medium-speed engines (41.3%<sup>5</sup> compared with 35%). Where Wills quotes an overall efficiency

1. Tombs, F, 1978, 'Economies of scale in electricity generation and transmission since 1945'.

2. Powergen and National Power on the U.K. mainland have scrapped this economy of scale approach which their precursor, the CEGB insisted upon - Electrical Review 8-12 February 1991.

For further references on economies of scale see:

Merlove, M, 1963, 'Returns to scale in electricity supply' or

Christensen, L.R and Greene, W.H, 1976, 'Economies of scale in U.S. electric power generation'.

3. See Wills, R.J, 1988, 'Slow-speed diesels for electricity supply'.

4. Diesels for electricity generation are either of the medium-speed, four stroke type or of the slow-speed, two stroke type.

5. Efficiencies reached at times in actual operation in Guernsey.

of 50% - 55% for slow-speed engines, but this does not compare with operating such engines on Guernsey. The slow-speed generators on the Island have not achieved overall efficiencies to date greater than 41.3%. This increased efficiency is assisted by the placing of a so-called 'efficiency booster' in the exhaust gases which drive a small auxiliary electrical generator.

Guernsey's new recently sanctioned '1D' (14.2 MWe) slow-speed generator is specified to have an efficiency of 45.62% at 75% engine load. Regardless, the increased standing load of the unit with roof mounted radiators, results in lower overall efficiencies similar to the existing slow-speed engines.

Slow-speed diesels are very expensive to purchase and burn Heavy Fuel Oil which, although cheaper than Gas Oil, is environmentally poor (currently no action has been taken on the Island with regard to pollution control of power station emissions). Wills<sup>1</sup>, in a later work, quotes a capital cost of slow-speed engines far lower than has been experienced on Guernsey. The total number of such installations of this type for base load electricity production (on islands) around the world are still not great.

While the large slow-speed diesels are higher in capital cost and require more substantial foundations than medium-speed engines they are easier to maintain. The prime

1. Wills, R.J et al, 1992, 'New local diesel power stations'.



factor in the SEB management decision to purchase them.

Slow-speed, two stroke diesels remain superior to medium-speed engines for electricity production. Nonetheless medium-speed, four stroke engines are more suited for use in cogeneration schemes. The gain in efficiency obtained with medium-speed, four stroke cogeneration (80% +) is a gain in ENERGY efficiency not merely electricity conversion efficiency. Which is a wider view and indicates where our attention should really be focussed when energy supply planning.

The present approach has led to the electricity network becoming increasingly centralised (large slow-speed units are intimately linked with centralisation). The adaptability of the centralised electricity network being constrained by the costly 33kV specialised transmission network it has created<sup>1</sup>. Such investment has also strongly influenced future electrical network developments, which we discuss in Chapter 10.

Distributed energy service provision, in contrast, depends on the 11 kV electrical network not for transmission but for distribution and final end-use.

A dispersed approach to energy planning has to consider the final end-user's energy requirements first by

1. To alleviate voltage problems out in the Island electricity network the SEB have installed two twin 33 kV underground circuits from Vale to 33 kV bus-bars at Kings Mills and Les Amballes, from which 11 kV loads can be supported.

considering the Quantity (Q), Quality (Q), Timing (T) and geographical location of end-users back to the centralised utility (ie. bottom up) instead of the other way round.

By starting with what we will call the 'QQT' of specific end-user needs, energy service provision can account for electricity and heat requirements rather than just merely electricity requirements.

For any real (meaningful) energy planning two principal conditions must be satisfied if distributed cogeneration is to be successful:-

- (1) There must be a demand for the distributed heat output.
- (2) The unit costs of cogeneration must be competitive with the present centralised offering.

The dispersed QQT and geographical clustering of energy needs within each parish are therefore considered in Chapter 6. The demand for the heat output in Chapter 9 and a comparison of the unit costs of distributed cogeneration (and also renewable options) in Chapter 11.

### **1.8 Energy service delivery**

Over the past few years a number of studies have been carried out on the supply and demand for electrical energy on Guernsey<sup>1</sup>. These studies have focussed on the potential sources of electrical energy and have forecasted the growth

1. For example Ewbank Preece Limited, 1985, 'Brief review of the SEB's future energy policy options' and also the States Electricity Board, 1984, 'Energy policy memorandum'.

of electricity consumption over the next decade and beyond. We will show that this has not achieved any energy savings for the Island; in fact energy losses have increased significantly.

No attempt has been made in previous work to evaluate the possibility of dispersing the power and energy base away from the present (historical) highly centralised approach. There is a need to examine this prospect in detail, in order to assess the potential benefits of cogeneration and the provision of energy services locally. The concept of distributed cogeneration does not just consider electrical energy alone but encompasses this wider energy view.

We will show that in addition to possible enhanced customer service and increased flexibility, distributed cogeneration will offer significant energy savings to the Island, and may even lower the cost of service.

The main questions focus on how, and to what extent, distributed cogeneration can be implemented in the Guernsey context<sup>1</sup>.

1. The possibility of decentralised sites (fuel storage, electricity and heat distribution network provision, aesthetic and environmental considerations) should not be quickly dismissed out of hand.

The historical emphasis on coastal sites for small power stations needs to be questioned; nowhere is far from the coast on small islands.

It will be demonstrated that energy supplied to different geographic locations is susceptible to Quality (Q), Quantity (Q) and Timing (T) variations, which may be significant in terms of energy planning.

It may well be appropriate to decentralise down to the level of the parish, which may be appropriate in the case of Guernsey because of its society; reflecting the very composition and basis of the internal government within the Island. Similarly, this may also be applicable to other small islands such as Jersey, which also have similar parish communities.

However, care needs to be taken to ensure that we do not fall into the trap of energy service provision based solely upon convenient administrative boundaries. We need to discuss the various levels of energy service delivery and take a view as to its relevance.

Distributed cogeneration raises questions of strategic importance and may potentially offer the Island:-

- (1) Reduced energy imports.
- (2) Reduced pollution emissions.
- (3) Better thermodynamic matching of supply and demand.
- (4) Economic benefits.
- (5) Increased security against the vagaries of the international energy market<sup>1</sup>.

1. The Gulf war in 1991 brought security of energy supply very sharply into focus on Guernsey.

A strategic energy conservation strategy using dispersed cogeneration, as advocated here, may dampen the effects of such future oil market disruptions.

Dispersion would lead to the implementation of an energy service culture rather than one of merely supplying electricity. The present work attempts to evaluate the potential of this change of approach and culture. Providing an original contribution to knowledge in the energy planning field in relation to very small (densely populated) islands, using new techniques and new methods of analysis.

## CHAPTER 2

### ENERGY AND THE ISLAND ECONOMY

Despite their obvious diversity, very small islands share, in common, many problems including energy, environment and transport. Important is an understanding of energy and the economy of islands, which is the subject of this Chapter. It leads to the conclusion that non-intervention in the energy sector by the States of Guernsey leaves Guernsey particularly vulnerable.

#### 2.1 Raising the quality of the debate

The first co-ordinated approaches to energy management on islands was the joint UNDP/World Bank Energy Sector Assessment Programme (1981) and Energy Sector Management Assistance Programme (1984)<sup>1</sup>.

The islands that participated in the programme included Fiji, Haiti, Jamaica, Mauritius, Papua New Guinea, Samoa, Solomon islands, Tonga, Turks and Caicos islands, Vanuatu and Seychelles<sup>2</sup>.

The usual considerations of these studies involved a review of (a) the petroleum sub-sector (b) the power sub-

1. A series of studies of the joint UNDP/World Bank Energy Sector Assessment Program. Funded in part, under the supplementary 'small-country assessment program' financed by the Swedish Government through the UNDP. The work carried out by the World Bank.
2. The Writer involved in the Seychelles study as Chief Engineer of the Seychelles Electricity Corporation Limited, 1982, 'Seychelles: Issues and options in the energy sector'.

sector (c) renewable energy options and (d) energy institutions and technical assistance.

The outcomes usually emphasised the pressing needs of:-

(1) Developing an appropriate and adequate energy database (usually meaning that what data is available is scant, and if available aggregate in nature).

(2) Developing fuel substitution options (usually meaning a detailed examination of all renewable possibilities is required).

(3) Instituting a conservation programme (usually meaning an information campaign to 'educate' end-users of the virtues of saving energy; along with various technical recommendations on how to improve electricity transmission losses within the power sub-sector etc).

(4) Rationalising petroleum prices (usually only relevant to island communities who impose stringent import taxes on imported petroleum products).

If island governments have been motivated at all by these studies, the response has usually been to:-

(1) Attempt to establish the required (reliable) energy (usually aggregate) database.

(2) Produce energy demand/supply analyses and forecasts (which are usually not helpful to anyone except the electricity utility's ambition to build the next bigger (centralised) power generation project).

(3) Formulate broad energy policy guidelines (usually so broad that they become unrecognisable).

(4) Analyse and develop programmes for manpower and technical assistance (usually relevant only to third-world island communities, who really do have problems with technical expertise).

This is piecemeal, the usual (actual) outcome is that nothing really changes. We will show that a holistic approach to the Island energy problem helps to produce new considerations and conclusions, from equally new data collection techniques.

Recently the EU have also become interested in the exchange of experience and knowledge in the area of energy management on the very small islands of the European Union<sup>1</sup>. The basic proposal is for the formation of an interchange 'network' (via telefax, E-mail etc) to facilitate the transfer of information (on what islanders are doing, or not) on energy issues, generation techniques and initiatives with a view to very small EU islands also becoming less dependent on outside fuels (but Guernsey does not fall within this initiative, see Section 1.3).

The EU islands concerned include Bornholm (Denmark),

1. See Western Isles Islands Council, 1993, 'Towards an energy charter and network for European islands' also

Office for Official Publications of the EU, 1994, 'Portrait of the islands'.



Western Isles/Shetland/Orkney/Isle of Man/Isle of Wight (U.K.), Madeira/Acores (Portugal), Island Trust (Ireland), Rathlin (Northern Island), Reunion/Guadeloupe (France) and Lesvos/Kriti/Rhodos/Mytilene/Vario Aigaio (Greece).

Over the years a number of these islands have been active (in a small way) in the field of energy, either on an individual or collaborative basis. Particularly in the area of energy sources (usually renewable wind and solar<sup>1</sup>) and attempts at more efficient control of energy consumption through demand side initiatives.

The EU proposal is an attempt at defining the potential energy saving on each island, along with the exchange of expertise and information between the islands (demonstration projects, exchange of technicians etc).

Important is that all of this activity seeks (for all of these islands) less dependence on outside fuels, but there seems to have been little published research with regard to the notion of total dispersal of the power and energy base on very small islands<sup>2</sup>. This may be because the data has not been so readily available and also because it involves intrusion into centralised utility activities, which by their very nature are commercially sensitive

1. Although the northern islands have the problem of climate.
2. Although Barbour, D.W, 1983, 'Energy supply for the island of North Ronaldsay, Orkney' for example questioned the logic of rejected waste heat from diesel generators. Even though only a very small, sparsely populated (122 people) island, the average waste heat was found to be equal to the average space heat requirement; "The waste heat being seldom utilised".

areas<sup>1</sup>.

The present work attempts to address this omission and should be viewed as a contribution to the body of knowledge concerned with energy management within the class of very small (densely populated) islands. Raising the quality of the debate with respect to a more strategic energy conservation approach, through dispersed cogeneration.

Additional references on energy and small islands are provided in the bibliography.

## 2.2 The economy

The performance of Guernsey's economy, particularly over the period since 1980, has shown an average growth of 5% per year, Figure 10.

The two oil shocks in 1973 and 1979 affected the world economy in two main ways. First a major stimulus to inflation was created and second, it generated a recession in world trade. The recession in the Guernsey economy in 1973 and 1979 is clearly evident from the Figure.

Peat Marwick McLintock<sup>2</sup> noted that Guernsey has experienced rapid growth and observed that the boom in the Island has been impressive in the context of the widest international comparisons.

1. Now even more so since the privatisation of the electricity supply industry on the U.K. mainland.

2. Peat Marwick McLintock, 1987, 'Economic appraisal of Guernsey'.

### Guernsey economic growth - reflated GNP (1990 values)

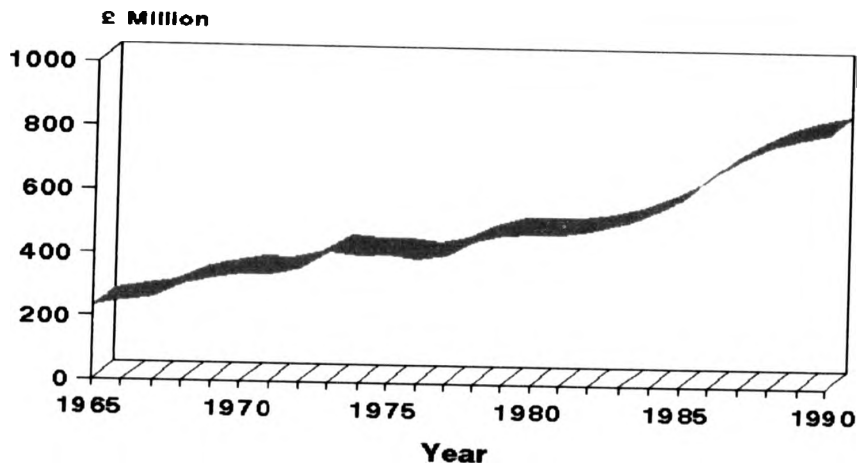

Source: Advisory and Finance Committee

Figure 10

Throughout its history the economy has relied on a succession of sectors for its prosperity: knitting in the 17th century, shipping and privateering in the 18th, quarrying and (later) vines in the 19th, and in the 20th century horticulture and tourism. The Island now has a new leading sector, financial services.

Figure 11 shows the contribution of sectors to the economy in 1973 and 1990, clearly showing the changes that have taken place over this period.

In 1990 all the major economic indicators showed little or no growth, Table 2.1. Reflatd bank profits, the number of tourist beds, reflatd horticultural exports etc remained at their 1989 levels, with the manufacturing sector suffering the loss of the largest manufacturer, Tektronix.

### % Economic contribution of export sectors to the economy

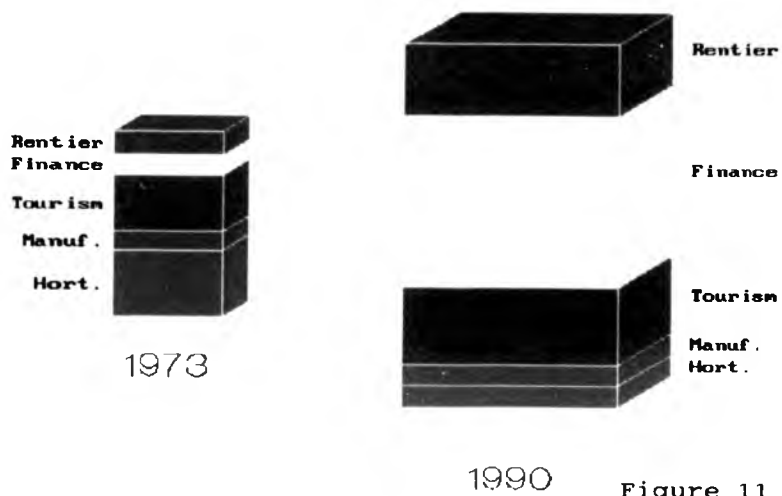

Source: 1991 Stat. Digest

Figure 11

**TABLE 2.1 - Main economic indicators  
(% changes - 1990 values)**

	Bank Profits (Comm/Fin.)	Tourist Beds (Tourism)	Manuf. Exports (Ind.)	Hort. Exports (Vineries)	Passenger Move: (Trans)
1986	23.6	- 5.1	- 5.5	- 9.6	1.6
1987	8.2	- 5.9	- 16.2	4.0	4.4
1988	5.3	- 10.1	- 16.9	5.7	5.5
1989	9.9	- 4.8	- 8.4	- 15.8	10.1
1990	- 0.9	- 2.1	- 42.9	6.8	- 1.5

Source: Billet d'Etat XVI 1991

Figure 12 provides the components of GNP for the period 1965-1986, reflatd to 1988 values, obtained from the States Income Tax Authority.

## GNP and its components related to 1988 values (1965 - 1986)

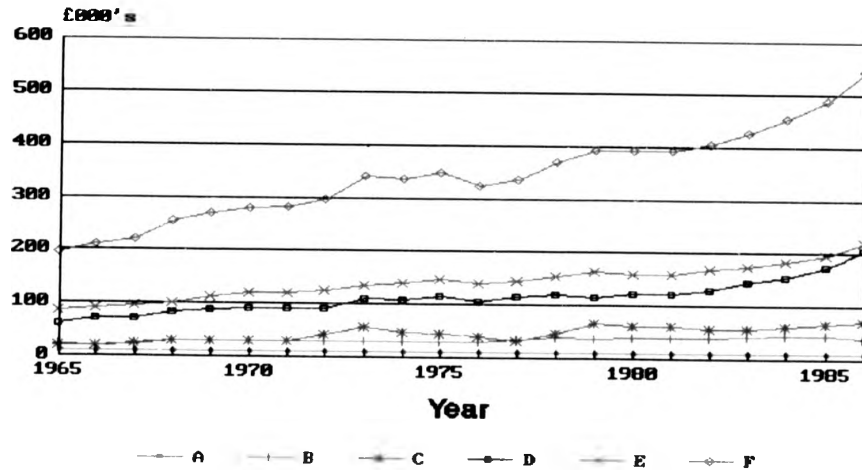

Source: States Income Tax Authority

- A - Land
- B - Total interest and dividends from outside sources
- C - Total internal interest and dividends
- D - Total business profits
- E - Net income from employment
- F - GNP

Figure 12

GNP data started to be collected on Guernsey in 1965, but because economic data is collected from income tax records the interpretation of the composition of GNP (particularly in relation to sector of origin) is not available.

Economic sectors for the purpose of our analysis can be described as follows:-

- (1) Commercial - dominated by the finance industry, which is dependent upon world wide markets for financial services, world wide economic growth, confidentiality (institutional arrangements are important).

(2) Tourism - main exporter to the U.K. mainland thus dependent upon a buoyant U.K. economy. Low and variable wages; interest charges are important in relation to gearing on borrowings for hotel refurbishment etc.

(3) Horticulture (vineries) - dependent upon the U.K. market thus again a buoyant U.K. economy is important, with strong competition from EEU imports.

(4) Industry (manufacturing) - exports to the EEU and the world market and has moderate and relatively fixed wages (currency conversion rate is important).

The first two sectors (Commercial and Tourism) are the largest, with concern presently being expressed that greater EU integration could create greater protectionism against the 'anomalous finance sector' (leading to calls for monetary/constitutional independence). The most significant economic factor on the Island to affect demand for energy has been the steady decline in the use of heated glass by the horticulture (vinery) sector.

The President of the States Committee for Horticulture in the 1985 Guernsey Growers Association Annual Report and Year Book<sup>1</sup> observed that:

"For over half a century we had lived in a protected U.K. market. When this protection started to be dismantled in 1973, followed in 1974 by a quadrupling of oil prices, we

1. Langlois, J.E, 1985, 'Guernsey Growers Association - Annual Report and Year Book'.

should have been embarking on a programme to ensure that we would remain competitive. There were some voices at the time which warned of the dangers and the need for action but the predominant Guernsey Tom seemed unassailable. We did not modernise our glass as we should have done in the early 70's; by the time we got around to it at the end of the 70s we were hit by the doubling of oil prices, spiralling interest rates and depressed prices on markets where we had to compete with heavily subsidised produce from other sources".

An indication of tomato exports to the U.K. is provided in Figure 13 which details horticultural revenue over the period 1965-1989. Between the two oil price shocks in 1973 and 1979 tomato exports fell by 33%. Since then they have dropped dramatically as Guernsey's competitiveness has been seriously eroded.

### Horticultural revenue (1990 Values)

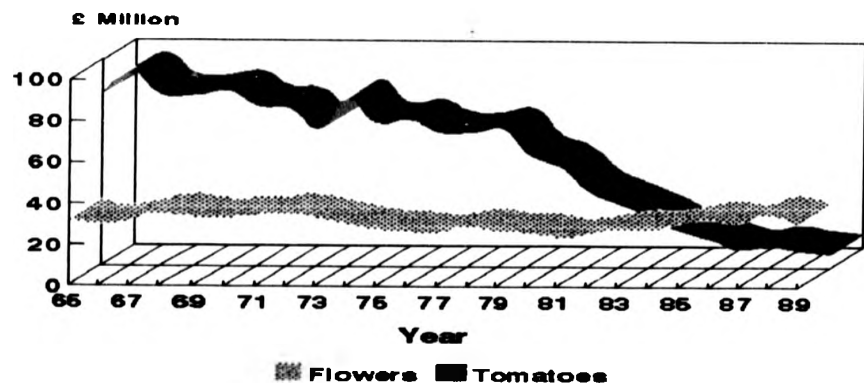

Source: Horticultural Committee

Figure 13

Island reliance on petroleum products and the sharp increase in the world price of oil pushed up considerably the production costs of Guernsey tomatoes. The State's laissez faire approach to Island oil imports and its derivatives contributed to the collapse of an important sector of the economy.

The present policy of leaving energy planning to market forces leaves Guernsey particularly vulnerable, and needs to be changed.

As a result of the rises in the price of oil in 1973 and, especially in 1979 (and hence the costs of heating greenhouses) and the resulting switch from tomatoes to flowers, the proportions of the commercial area under glass run hot and cold has altered dramatically.

The sector has adapted as best it could by converting to 'cold' greenhouses, by lagging pipes and by lining gable-ends and fronts. Moreover, it also has had to compete with countries like Holland who soon had an ample supply of cheap natural gas available.

During the late 1960's nearly 80% of the commercial area under glass was heated and this was still true of nearly three-quarters at the time of the second oil price shock in 1979. Subsequently the proportions have reversed



and in 1986 only 25% of the commercial area was run hot<sup>1</sup>.

For additional references on energy in the economy see Slesser<sup>2</sup> or Curran<sup>3</sup>.

### 2.3 Energy per capita

The traditional wood, water and wind<sup>4</sup> energy on the Island was first gradually replaced by imported coal<sup>5</sup>.

The consumption of coal was stimulated by four inter-related factors:-

(1) A shortage of firewood - without planned reforestation, increased shortages of wood gradually forced Guernsey householders to look to coal for their heating and cooking fuels.

(2) Growth in population.

(3) Rapid increase in the level of activity within the horticultural industry.

(4) The growth of the Island economy itself.

1. See Horticultural Advisory Service, 1987, 'A strategic overview of Guernsey horticulture - Consultation document' also

Guernsey Evening Press, 20 February 1986, 'High cost of heating contributes to glasshouse area decline'

2. Slesser, M, 1978, 'Energy in the Economy'

3. Curran, J.S, 1979, 'Energy and human needs'

4. Detailed research by the Rev. Wm. Kilshaw of St. John's vicarage provides the location of most historic windmill sites on Guernsey.

5. Coal is the fossil fuel that underpinned the industrial revolution on the U.K. mainland.

Figure 14 shows the coal imports into the Island from 1950 to 1990.

Between 1960 and 1970 fuel oil was then substituted directly for coal, Figure 15.

Applying regression analysis to the two variables, coal (y) and fuel oil (x) over the period, indicates strong linearity, with the form  $y = - 0.765x + 1897$  ( $R^2 = 0.964$ ).

### Coal Imports 1950-1990

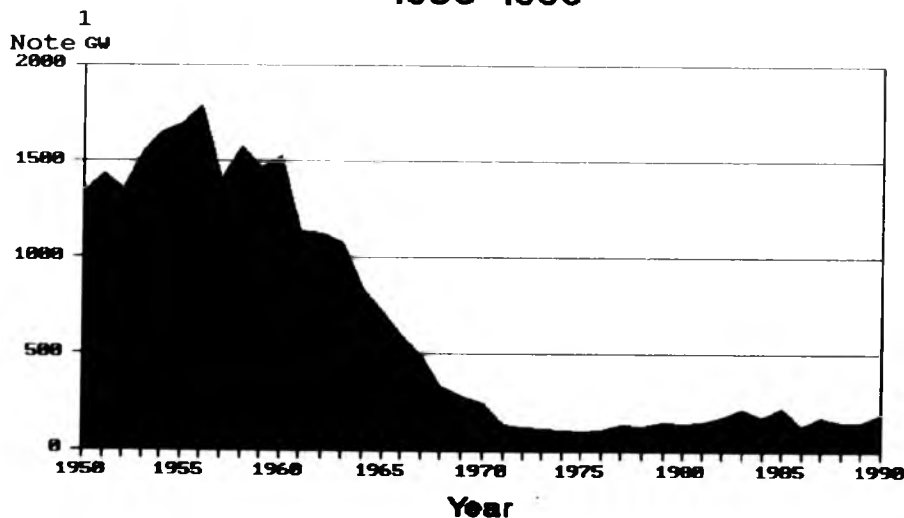

Source: Customs & Excise

Figure 14

1. Prime fuel, not derived electricity (see APPENDIX A, Energy measurement).

Materials from which energy is derived are usually referred to as 'fuels', a word derived from the old French word 'fouaille', meaning material for burning.

Rather than provide some rigid definition of the word 'fuel' it is helpful to use it in as broad a sense as possible. Two quite distinct groups of fuel can be recognised and these are usually referred to as 'primary' (naturally occurring raw material) and 'secondary' (derived from a primary fuel).

## Fuel Oil Imports 1950-1990 (HFO + Gas Oil + Kerosene)

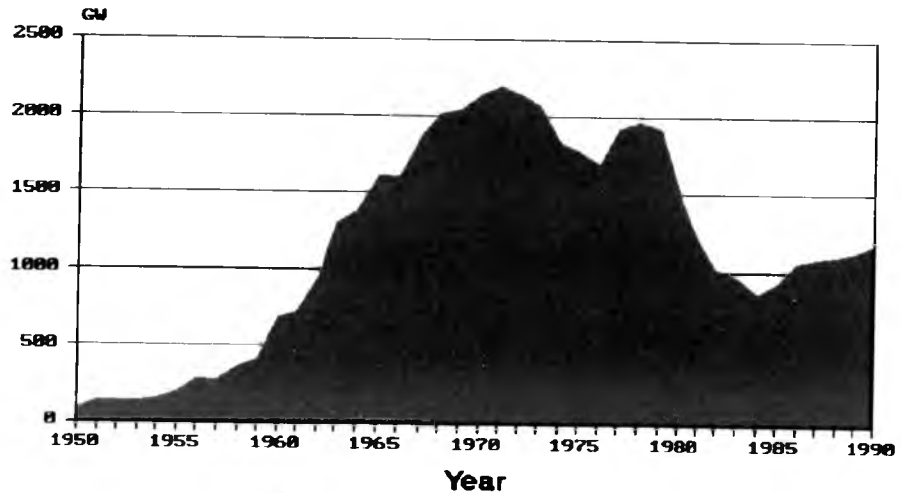

Source: Customs & Excise

Figure 15

Most writers argue that coal prices did not drive consumers to an oil substitute, simply the generic advantages of oil, or some other energy source (eg. gas or electricity) prompted the switch. An equivalent amount of energy in fuel oil being stored in a fraction of the space demanded by coal. This and other advantages of fuel oil (control, clean etc) also carried cost benefits but they were reflected in enhanced efficiency and convenience rather than in a cheaper initial price per energy equivalent unit of coal<sup>1</sup>.

1. Discussions with coal importers on why this substitution occurred on Guernsey suggests that fuel oil provided Island growers in particular, with greater control over temperatures within their vinerias, along with greater convenience. Confirming this view.

Studies of per capita energy consumption have revealed very wide differences in energy consumption between developed and developing islands. The differences are the result of a complex interaction of factors which include the energy intensiveness of the dominant economic sectors, the distribution of wealth, geographical location, social habits etc. Energy per capita and GNP per capita for Guernsey is provided in Figure 16.

### Energy/capita + GNP/capita (1990 Values)

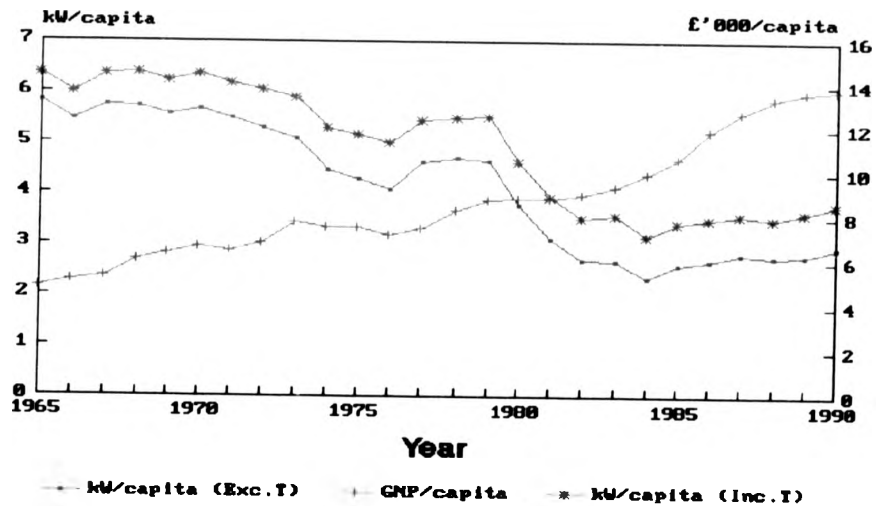

Figure 16

The energy intensity in an economy will vary over time, as can be seen with the Guernsey economy. Falling energy intensity demonstrates the collapse of the growing industry and the advancing role of the financial services sector. The apparently more efficient use of energy reflects mainly structural changes. This trend appears to

have ceased in 1984 and what we are seeing today is marked and disturbing.

#### 2.4 Inadequate energy policies

Traditional Island wood, water and wind have been allowed to decline in favour of fossil fuels, particularly oil products. The possibility that there might one day be an energy shortage has not been admitted, but this should not be dismissed. In the space of a few years the world energy situation has pivoted from scarcity to oversupply, from a seller's market to a buyers. With many students of the energy scene agreeing that the present glut is likely to be temporary.

Energy problems have been aggravated by inappropriate policies and institutional constraints on many small islands, particularly those which have no indigenous energy resources of their own like Guernsey.

Policy making on the Island is in the hands of the Advisory and Finance Committee who have taken a consistent line on non-intervention in the energy sector (the only States owned body operating within the energy sector is the States Electricity Board).

The Committee have stated<sup>1</sup> that:

**"Dependence on oil as the main source of primary energy is likely to continue for some considerable time. This renders the Island vulnerable to significant changes in the**

1. Billet d'Etat XVI, July 1988, p.594.

price or availability of petroleum products".

The President of the Committee has also noted<sup>1</sup> that:

"We already have an energy policy. It is to secure supplies, save energy to the greatest possible extent, consistent with financial sense, and to keep an eye on renewable energy sources".

Many islands such as Guernsey, especially since the first oil shock in 1973, have not assessed the strategic implications of dependence on oil imports and have not opted to interfere in their own energy markets.

The Island has maintained a complete dependence on international energy markets. Energy policy being driven more by the international oil companies (in Guernsey's case: Shell, BP, Total and Esso), rather than being driven by the Island itself.

We will show that significant energy savings are available to the Island, but for this to happen, a move away from the present laissez faire stance will be necessary.

The recent stabilisation and even decrease in crude oil prices has not reduced the need for careful energy planning. The uncertainty associated with predicting the availability and price of energy still remains.

1. See GEP, 2 August 1985, 'Nuclear industry like a cancer on this earth' - Report on States of Deliberation debate.

Because of the importance of imported oil products into the Island, even moderate savings through distributed cogeneration and renewable sources may result in a significant improvement in the Island's energy position, but this needs to be tested.

Energy related investments, at the aggregate Island level, continue to be planned and implemented without any real consideration for the potential of energy conservation<sup>1</sup>. This perpetuates dependence on outside sources of energy.

Elsewhere also (for example the 'Jersey Energy Supply Study'<sup>2</sup>) recommendations for new oil fired diesel generating capacity are confirmed as justified at existing centralised power stations<sup>3</sup>. Without wider (holistic) energy considerations taken into account; Konis<sup>4</sup> also indicates that a similar situation exists on the island of Cyprus. A much wider view of island energy is required.

References on world energy resources are provided in the bibliography.

1. The decision of the SEB in 1990 to purchase a further Sulzer 14.2 MWe slow-speed diesel generator, again to be located at their centralised power station for example.
2. W.S. Atkins Management Consultants with Merz and McLellan, 1989, 'The Jersey Energy Supply Study'.
3. Progress of work on the study was hindered by the inability to obtain timely and comprehensive information about the electricity sector. The study being flawed in that it did not consider energy conservation within its terms of reference.
4. Konis, C.Y, 1991, 'Energy management and conservation in the hotel industry of Cyprus' - PhD thesis (University of Stirling).

## 2.5 Co-ordination

Energy policy and administration on the Island is conducted among a number of States of Guernsey committees (Advisory and Finance, Board of Administration, Electricity, Transport etc) with less co-ordination than required by the complexity of the matters considered<sup>1</sup>. This results in delays in decision making, conflicting decisions or even no decisions at all.

Following the resolutions of the States in September 1987 (Billet d'Etat XIX, P.135) the Board of Administration became responsible for operational matters concerning energy co-ordination in relation to States buildings ONLY. With the appointment of a part-time energy officer to formalise this activity, who reported<sup>2</sup> in 1989 that:

"at the present time, the actual energy use and therefore cost for States buildings is not accurately known".

This is all piecemeal, with a complete absence of any holistic strategy relating to Island energy matters. Energy related considerations (such as energy conservation, implementation of renewable sources etc) are rarely taken into any serious account. There is a requirement for a new

1. At present the responsibility for formulating energy policy lies with Advisory and Finance and for implementing it with the Board of Administration. The States Electricity Board provides electrical energy and the Island Development Committee and Housing Authority are involved in the planning of energy use.

2. See Technical Services Department (Architectural division), 1989, Annual Report.



quantitative energy planning environment for decision making, within a much wider energy planning forum.

Even in a small island such as Guernsey the States Electricity Board (SEB) appear to be a States owned, centralised utility with an existence all of its own (remote and unaccountable).

Not really under the control of the States of Guernsey, the SEB have only nominal accountability to electricity customers and the public in general. Seen by the workforce, customers and the public alike as possibly belonging to 'them' and not to 'us'.

The SEB should not have a monopoly in framing Guernsey's energy strategy because their business is focussed on producing and selling units of electricity. They may not necessarily be acting in the best interests of the Island (using high quality electricity for space and water heating is questionable, although justifiable in certain contexts such as off-peak supply).

Current electricity planning is seen as a need to explain, even to the owners (States of Guernsey), only the minimum. Letting people know what has already been decided and partly why it has been decided. Consulting energy end-users and the wider public in the planning process is conveniently not really addressed.

#### **2.6 Direct intervention**

The present U.K. Government's energy policy is clearly,

influenced by the belief that market forces are the most effective method of regulating their energy market and allocating resources in the energy market<sup>1</sup>.

On the contrary, the present work hypothesises an energy regulatory environment for Guernsey within which market disciplines are allowed to operate, but based upon:-

- (1) Clear responsibility for energy strategy to be vested within the political framework.
- (2) Regulatory activity based upon the monitoring and enforcing of established policies.
- (3) All energy end-users being involved in decision making.

With clear accountability for energy planning and regulation on the Island, and a forum enjoying the participation of all interested parties.

This would remove the existing institutional problems/ barriers described and provide a way forward; the focus now being on the energy service requirements of end-users. The centralised approach does not really encompass the energy services that end-users require such as comfort, illumination, mobility etc. Nor does it really encompass the energy hardware that converts fuel and electrical energy to provide these energy services.

The States, acting through a regulatory mechanism as

1. See the Economist, 21 August 1993, 'Britain is launched on an audacious experiment in energy policy: not to have one'.

part of a formal 'States of Guernsey Energy Management System', has some vital roles to perform in order to bring this change about.

The present work suggests that it may not be adequate to leave energy management in relation to small island communities entirely to market forces alone. Market mechanisms of themselves may not be adequate to balance the intrinsically conflicting objectives of:-

- (a) Obtaining the cheapest possible energy.
- (b) Ensuring security of supply.
- (c) Reducing the risks associated with over-dependence on particular energy sources (such as petroleum products).
- (d) Protecting the environment.

Market mechanisms are an essential discipline but may not be a final substitute for political choice. However, the present work is concerned with modelling some of these choices, rather than with 'political' decision.

The SEB exists to supply electricity; Gas Energy on the Island exists to supply gas; the four oil companies exist to supply oil; British Fuel exists to supply coal. Each does so in competition with the others. Though it would be wholly unjust to suggest that these companies have no sense of social responsibility, it is not the responsibility of any individual centralised energy supplier to do what is best for the Island or the global environment. Such an outcome

can only be achieved through the direct intervention of the States of Guernsey.

All of the strategic energy conservation, environmental and economic reasons for having a formal energy management forum may also apply equally to transport energy. Indeed transport energy usage may be of greater relevance environmentally.

A systemic model for direct market intervention by the States of Guernsey is provided as a separate 'tool' in Chapter 3.

#### 2.7 Disaggregated information

We will show that the energy needs of small (densely populated) islands may be better met and matched by considering decentralised clusters of demand. By taking their local needs for heat (as well as electricity, at different times of day and season) and matching these to locally generated supplies from energy service companies<sup>1</sup>.

This is all location specific, and depends on the local profile of QQT demands (there is no single solution).

We will show that there are benefits to the Island from near optimal use of input fuels in relatively low cost, tailored supply units, but this is only achieved by good

1. It could be argued that the supply side is the only side that can truly be managed. The approach in the present work is to consider meeting current Island energy demands and then later to take a view on demand side measures. However, clear demand side forecasts (ie. marketplace potential) is an essential prerequisite of sensible supply side investment strategies.

energy planning (careful local measurements and analysis) and sound techno-economic design in individual situations. Something which traditional (centralised) energy planning on the Island simply does not address.

Distributed cogeneration may offer an as yet unexplored option on Guernsey.

In order to consider this it is essential to provide greater disaggregated information on (a) economic activity (b) energy demands and (c) renewable resources, which are all necessarily location specific. This is not an easy set of tasks; the present work proposes to test the quantifiable benefits of this bottom-up approach however.

A much more accurate end-user data collection process is required rather than just merely the present (sparse) aggregate Island energy statistics. Computer based planning can be useful here since it serves as an information bank and also allows energy data development. Such a detailed database did not exist on Guernsey<sup>1</sup>; the research undertaken as part of the present work attempts to provide it.

Our research effort investigated major end-user energy demands at locations throughout the Island to identify the types and characteristics of consumption patterns (see Chapter 6). It found that the effect of a large hotel or

1. This is usually the case in most other small island situations.

industry in one part for example dominated energy demand in that location.

All of this provides an idealised approach and quality of data collection that has not been available from research work in other small island situations, and should lead to sound energy planning<sup>1</sup>.

**The development of indigenous renewable energy resources:**

A realistic appraisal of the extent of local indigenous energy potential on the Island is also important (one of the attractive features of renewable energy is that they are dispersed supply sources). It will be shown however that these potential (location specific) renewable energy sources may only contribute in a very limited way to meeting the Island's energy demands, without significant changes in end-user behaviour (see Chapter 9).

**Switching fuel, especially away from oil:**

This will be shown to be questionable, with a high capital investment required in most cases (for example an electricity cable link to the French mainland, see Chapter 8).

What is needed from strategic energy management is a far more innovative way of looking at energy conservation, which goes beyond merely switching fuel.

We will show that this involves QQT matching the local

1. The detailed characteristics of aggregate (historic) energy conversion and distribution are also provided in Chapters 4 and 5.

energy demand profile with the appropriate energy source to avoid the present 'reject heat' losses from centralised power generation on the Island. All of which is a long-term solution to the energy problem, and will require States of Guernsey intervention in order to make it happen.

## CHAPTER 3

### METHODOLOGIES EMPLOYED

A diversity of interests are involved in the energy problem on Guernsey (see Section 1.5) with the debate on energy issues often confused and conflicting; a piecemeal approach is therefore unsatisfactory. A holistic view taking system/subsystem interactions into account is essential.

This Chapter concludes that a systems approach, using Soft Systems Methodology (SSM), is a suitable methodology for dealing with the energy problem on the Island. It proceeds to set a soft systems model against reality by notionally operating the model on paper, and then uses it to order our research effort and thesis presentation.

#### 3.1 Approach to the energy problem

There is a requirement to ask as to "what kind of problem situation can be 'managed' with which sort of methodology?".

A system dimension offers the required holistic approach, which deals with complexity in terms of the 'system' or 'systems' that make up the problem situation. The difficulty is in knowing which to use from the range of systems methodologies available, which are described by Flood et al<sup>1</sup> for example, as follows:-

##### (1) Operational Research (OR)

1. Flood, R.L and Jackson, N.C, 1991, 'Creative problem solving'.



- (2) Systems Analysis (SA)
- (3) Systems Engineering (SE)
- (4) Systems Dynamics (SD)
- (5) Viable System Diagnosis (VSD)
- (6) General System Theory (GST)
- (7) Socio-technical Systems Thinking (ST)
- (8) Contingency Theory (CT)
- (9) Social Systems Design (SSD)
- (10) Strategic Assumption Surfacing and Testing (SAST)
- (11) Interactive Planning (IP)
- (12) Soft Systems Methodology (SSM)
- (13) Critical Systems Heuristics (CSH)

The question as to which of these is the most suitable when dealing with the energy problem on Guernsey, can fortunately be resolved. It is possible to provide guidelines that point to the relative strengths of the different systems approaches, which can help to suggest when a situation favours the use of one rather than another (Ibid). This can be done by grouping the problem contexts according to two dimensions:-

- (a) Systems
- (b) Participants

The systems dimension relates to the relative complexity in terms of the 'system' or 'systems' that make up the problem situation. The participants dimension relates to the relationship between the individuals or parties who stand to gain (or lose) from a systems intervention.

We can classify systems as a continuum of 'system types'; at one end, relatively simple systems and at the other highly complex. In terms of participants, the classification can be unitary, pluralist and coercive. From this, the range of systems methodologies can be grouped according to assumptions made about problem situations,

TABLE 3.1.

TABLE 3.1 - A grouping of system methodologies based upon assumptions made about problem situations

	Unitary	Pluralist	Coercive
Simple	OR		
	SA	SSD	CSH
	SE	SAST	
	SD		
Complex	VSD		
	GST	IP	
	ST	SSM	?
	CT		

This provides us with some guidance as to which methodology we should put to work and the kinds of issues or 'problems' for which they are most suitable.

The energy situation on the Island for example can be adequately described as complex and pluralist. The systems methodologies most suitable are 'Interactive Planning (IP)' and 'Soft Systems Methodology (SSM)'.

#### Interactive Planning (IP)

Ackoff's<sup>1</sup> work recommends 'Interactive Planning', which

1. Ackoff, R.L, 1974, 'Redesigning the future'.

has as its most original element, the idea of participation.

It depends on all the stakeholders being prepared to enter into participative planning concerning the future. In the Guernsey energy problem situation however, this is unlikely to be appropriate because of the dominant position of the SEB for example. Who are unlikely to participate in idealised design and forego their current position (where objectivity is of major concern).

### **Soft Systems Methodology (SSM)**

Checkland's<sup>1</sup> work primarily deals with soft<sup>2</sup> systems modelling exercises which require a fair degree of time and effort. The methodology is appropriate and useful in the Guernsey energy problem situation for the following reasons:-

- (1) The way in which it reveals the system (unravelling the complex unstructured problem)
- (2) It questions the system and produces new classes of problem (the critical genesis of Root Definitions, then taking each apart and questioning how they apply for example).
- (3) It focusses recognition on the fact that there are

1. Checkland, P.B, 1981, 'Systems thinking, systems practice'.

2. The term HARD and SOFT are used frequently in SSM, the distinction between the two are:

HARD systems approach - prescriptive techniques that address clearly defined problems.

SOFT systems problems - used when the problem is not clear.

alternative system boundary definitions (and hence may help to point to energy supply solutions).

(4) It enables comparisons (between centralised and distributed energy provision for example).

What SSM does not do is prescribe the simulation modelling (this is a choice we have made), and we use a computer based methodology, which we describe in detail in Chapter 7.

Important is that our concern here is the management structure of resource utilisation and how current resource management can be improved. The central aim of the present work is the reduction of petroleum product imports into the Island.

A technology that can assist us (and is a demonstrable 'real world' tool, not a perverse technology) is cogeneration (which already exists and has been proven): In Chapter 8 we examine the present status of 'technical fix' technologies in order to demonstrate that this is a feasible reality. Cogeneration is very flexible, and we use it in the present work as an illustrative mechanism to change radically the current management structure of resource utilisation on the Island.

The nature of the problem though may change if new technologies appeared; the management structure may then have to change also as a result. But all the signs are that it may be another 30 years before this radical change

happens.

The consideration of cogeneration implies change in currently used technology and management on the Island, and is only one scenario of possible outcomes (albeit one of the most difficult to quantify). If in the future energy source technology further developed, the disaggregated models produced as part of the present work could still be used.

One of the most frequently used sources of inspiration for problem solving is experience. The Writer's basic discipline is electrical engineering, which does not necessarily help in providing innovative solutions to the problem in hand, indeed, it might introduce distracting technical bias<sup>1</sup>. There is a need here to break free from convention and where SSM can be very powerful.

With complex unstructured problems, there is no single analytical technique or approach which can solve these kind of problems<sup>2</sup>. A number of skills are required to understand these situations (analytical, application, creative, communication, social, self-analysis, model building).

1. "It is not surprising that engineering as a professional activity attracts action-orientated people who value practical achievement above all else. A result of this is that engineers are impatient with theorising; after a good design has been successfully realised in practice they are little inclined to analyse the way they went about achieving it." Checkland, P.B, 1981, 'Systems thinking', p.128.
2. The search for some super-method that can address all complex unstructured problems is mistaken. Equally it would be wrong to revert to a trial and error approach to solve problems.

Creative problem solving may be the work of politics, but as Greenberger et al<sup>1</sup> notes:

"Politics deals in pressure, power and negotiation, not optimisation or rational deduction. Its instrumentalities are coalitions, compromise and reciprocity, not decision rules, computer models, or payoff functions".

A pragmatic view of problem solving offers no fundamental or unique way of dealing with the real world. Essentially the world is what it is and all we can hope to do is to achieve outcomes which are more, rather than less, successful. This emphasises experience, practical solutions, power etc (a typical engineering approach).

SSM offers in contrast an overall approach, which potentially offers a more useful aid to the problem solving on Guernsey. It does not yield a unique solution but there is no unique solution; but its relevance and optimality (in the light of long and medium term economic evaluations) need to be verified.

Checkland notes that:

"Systems thinking will appeal to all those people in any discipline who are knowledgeable enough to know that there is much they do not know, and that learning and re-learning is worthwhile. For such people a systems approach is not a bad idea".

1. Greenberger, M, Brewer, G.D, Hogan, W.W and Russell, M, 1983, 'Caught unawares: The energy decade in retrospect'.

Systems thinking has rarely been applied formally to the energy sector before, thus there are no examples of this from the Lancaster School of Systems<sup>1</sup>. It offers the prospect of a rich learning experience and an ordered approach to our research effort.

The consequences of the systems approach is that it can highlight that fundamental changes may be needed. More importantly, it demands that problem solving be carried out on a more interdisciplinary basis and that the way things are presently organised may need to be organised in a more integrated way. This is particularly useful in the energy sector where a number of disciplines are represented and where a large number of social, technical and economic interactions might be expected.

### 3.2 Systems thinking and the energy situation

The real world is complex, dynamic and ambiguous, as portrayed by the energy situation on Guernsey for example.

**Complex**, because it contains a large number of factors.

**Dynamic**, because the number and significance of factors and their interconnectivity varies with time.

**Ambiguous**, because there is an absolute limit to our knowledge of the real world. It reflects our ability, time, availability of knowledge etc, which can be used selectively to support different values and views. No one description of

1. See Department of Systems, University of Lancaster, 'List of PhD theses 1970-89.'

a complex situation is likely to be acceptable to everybody<sup>1</sup>.

Whilst systems thinking may have a wide range of classifications, we will concentrate here on systems most relevant to strategic 'Island' energy management activities. This is a human activity system (but other classifications exist<sup>2</sup>).

The activities of human activity systems can be placed in four classes:-

- (1) Primary activities (inputs into outputs).
- (2) Secondary activities (caring, renewing, adapting etc).
- (3) Management activities (innovating, planning etc).
- (4) Anti-thetical activities (a consequence of dealing with human activity systems).

The properties<sup>3</sup> of such human activity systems can be described as:-

- (1) The need for a name
- (2) It should have a purpose
- (3) It should have resources

1. Checkland calls this different W's (WELTANSCHAUUNG or 'World views').

2. For example:-

Natural systems (jungle etc).

Designed abstract systems (mathematics, poems etc).

Engineered systems (cars, space rockets etc).

Transcendental systems (the idea of God).

3. See Beishon J and Peters, G, 1972, 'Systems Behaviour' for example.



- (4) Openness
- (5) A process
- (6) A structure
- (7) Behaviour

Optner<sup>1</sup> argues that management objectives should in fact not be to treat solutions to problems as special cases but to look upon them as setting up, running and maintaining these human activity systems.

As mentioned earlier, the terms HARD and SOFT are used frequently in most explanations of the systems approach<sup>2</sup>. Much of the original systems thinking work was carried out in the context of the engineering of complex physical systems; such structured problems are what HARD systems thinking are concerned with<sup>3</sup>.

Greater difficulty is experienced as problems become less structured, which result in sets of inter-dependent problems. These (problems) are often described as 'problematical' or 'messy' (ill-structured problem situations). The energy situation on Guernsey is an example of this type.

Checkland describes such situations as SOFT problems; a

1. Optner, S.L, 1965, 'Systems analysis for business and industrial problem-solving'.
2. Not to be confused with hard and soft energy paths.
3. See Jenkins, G.M, 1971, 'On the definition of 'systems' in systems engineering.

problem which cannot be formulated as a search for an efficient means of achieving a defined end; a problem in which 'ends' and 'goals' are themselves problematic.

It is useful for the purposes of our analysis to take the energy situation on Guernsey as being one undertaken for a client, and pose questions such as:-

**Who is the client ?**

The States of Guernsey.

**What are his aspirations ?**

A feeling of unease about the energy situation and the future; may not fully recognise ownership of the problem.

**Who are the occupants of the roles 'decision taker' and 'problem owner' ?**

Decision taker - States of Deliberation (see Section 1.2)

Problem owner - The States of Guernsey

**The 'decision taker'/'problem owner's' version of the nature of the problem ?**

The past decade has transformed a quiet tomato-growing and tourist Isle into a busy offshore international financial centre. Concern has been expressed about the future of energy, on an island where new wealth has brought an increasing standard of living. The 'old indigenous' population may not have been instrumental or beneficiaries in this transition.

**The 'decision taker'/'problem owner's' reasons for regarding 'the problem' as a problem are ?**

Guernsey relies for all its primary energy requirements on imported oil and its derivatives.

Energy tariffs are higher than on the mainland.

Decisions have to be taken within changing frameworks.

Pressure on the infrastructure.

Social change.

Pressure groups Global Co-operation/Friends of the Earth etc

Land use constraints.

**The 'decision taker'/'problem owner's' expectation of the problem solving system ?**

To provide advice and guidance on the management of the Guernsey energy system as a whole, in the context of an overall vision of energy use.

SSM recognises the difficulties of defining these problems and suggests that time is spent exploring the 'RICHNESS' of the problem situation (SSM Stages 1 & 2).

Usually some features emerge to characterise the situation, which can be summarised in a rich picture. Which is particularly unscientific, but is generally based upon the theory that 'a picture tells a thousand words'.

There are five broad classes of variables affecting the evolution of Island energy patterns:-

- (1) Economic
- (2) Demographic
- (3) Technological
- (4) Institutional
- (5) Geographic

These are interdependent and form the basis of the 'messy' soft energy problem situation on the Island.

A system must have a boundary and how it is defined is an essential 'key' step. The advantage of a small island situation is that there are very well defined physical boundaries, although these may not necessarily be the same as the problem boundaries (inter-parish energy schemes for example).

The Guernsey rich picture is provided in Figure 17, and was constructed from early thoughts about issues that might be relevant.

**RICH PICTURE:**

Environment: Monopolies exist in electricity, gas & coal.  
 All primary fuels are imported.  
 Parish-based energy activities.  
 Requirements of the Companies Law.  
 Technological change.  
 Politics.  
 The States of Guernsey: Fiscal policies.  
 Land-use planning.  
 Acts of God

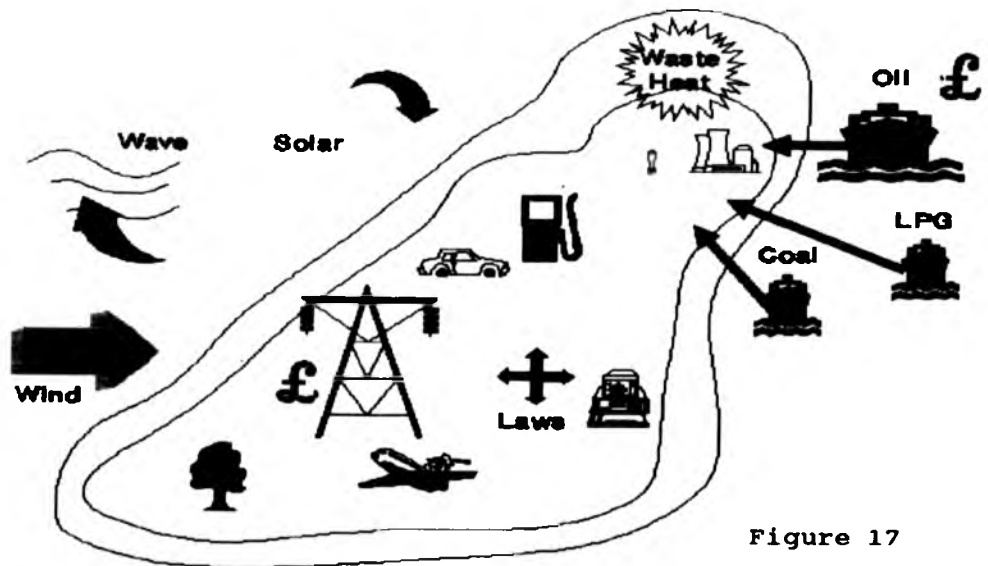

Figure 17

The transition from Stage 2 to Stage 3 of the SSM are the NAMES of systems which appear to be relevant to the problem situation. They reflect the different viewpoints or World Views (Ws) which can be adopted, and the more radical/creative these are the more likely they will be insightful<sup>1</sup>.

### 3.3 Conceptual model building

Stage 3 of the SSM is the production of a concise, tightly constructed description of a human activity system which states what the system is (ie. its ROOT DEFINITION).

The core of a root definition (RD) of a system is a 'transformation' process (T); the means by which defined inputs are transformed into defined outputs.

There will be 'ownership' (O) of the system; some agency having a prime concern for the system and the ultimate power to cause the system to cease to exist.

Within the system itself will be 'actors' (A); the agents who carry out the main activities of the system, especially its main transformation.

Within and/or without the system will be the 'customers' (C) of the system; beneficiaries or victims affected by the system's activities.

1. For example:-

RADICAL - A States of Guernsey owned system to reduce the desirability of the environment by producing pollution !

CREATIVE - A States of Guernsey owned ecosystem support system.

Fifthly, there will be 'environmental constraints' (E) on the system; features of the system's environments and/or wider systems which it has to take as 'given'.

To these five elements a sixth item is added which by its nature is seldom explicit in an RD but which cannot be excluded. Which is a 'world view' (W), an outlook, framework or image which makes this particular RD meaningful<sup>1</sup>.

Underlying much of the energy debate on the Island is a divergence of views about what the energy problem 'really' is. Society has mechanisms only for resolving conflicting interests, not conflicting views of reality; perceptions can and do differ markedly.

The exposure of other world views (for example, 'devising an effective and capital efficient energy investment plan', with no mention of energy efficiency or the environment) may be equally valuable and valid. All of which are none the less important to the thesis development.

The selection and justification of a particular choice of world view however (within the galaxy of choice) need not be arbitrary. A decision on which of the several prevalent world views is the most useful can and should be made on a few basic values:-

1. These six elements covered in a well-formed root definition are remembered by the mnemonic CATWOE, which can be used to test a root definition. It does not tell you if the root definition is good in the sense of 'useful', but it does tell you if it is good in the sense of 'well formulated'.

(1) The approach should be not to expand centralised energy supplies indefinitely but to offer more innovative solutions, and consider more local clustering of energy needs, using a minimum of energy.

(2) Ordinary people are qualified and responsible to make energy choices through the democratic political process.

(3) The less energy very small islands need, the greater the security and the less vulnerable they are to circumstances outside of their control (such as sudden price rises and scarcity of supply).

(4) Using the non-interventionist, laissez faire, approach of the past has done little to save energy; in fact there may have been wilful profligacy (see Section 1.6).

All of which reflects the sort of world view that requires that:

"The States of Guernsey should intervene in the imperfect energy market and disperse the power and energy base, within a formal energy planning framework. With the preeminent aim of significantly reducing petroleum product imports".

What makes this world view the best or more meaningful is the requirement of direct intervention (via a regulatory transformation), rather than some uncoordinated foray into the imperfect energy market.

Several RDs flow directly/obviously from this world

view and have been formulated in the course of our work. A CENTRALISED ENERGY PRODUCTION -----> DECENTRALISED ENERGY PRODUCTION transformation within one of the RDs lost the richness gained by the pairing of BEING and DOING, which the RD/Conceptual Model relationship should provide. This was abandoned along with others.

The formulation of RDs with several transformations lead nowhere, and model building becomes impossible (the model quickly becomes unmanageable).

The most insightful RD/Conceptual Model combination came from the following:-

#### **ROOT DEFINITION**

**A States of Guernsey owned system concerned with regulating the energy market on the Island, taking both the environment and infrastructure needs into account whilst not aggravating social and economic development.**

The CATWOE test for this selected root definition is as follows:-

**C - The island of Guernsey<sup>1</sup>.**

**A - Civil servants.**

**T - Unregulated energy market into a regulated energy market.**

1. Within CATWOE the most common mistake is to define C, the system's beneficiaries or victims, as some persons who are affected by the system, but at several removes (final energy end-users for example).



W - The States of Guernsey should intervene in the imperfect energy market and disperse the power and energy base, within a formal energy planning framework. With the preeminent aim of significantly reducing petroleum product imports.

O - The States of Guernsey.

E - Legal authority for action. Within a limited budget. Should lead to reduced petroleum product imports.

The NAME of this system is the "States of Guernsey Energy Management System (SOGEMS)" and the root definition can now be elaborated in a CONCEPTUAL MODEL, Stage 4 of SSM.

The conceptual model (CM) should accomplish what is defined in the RD. The RD is an account of what the system 'is'; the CM is an account of the activities which the system must 'do' in order to 'be' the system named.

At its simplest, a system<sup>1</sup> can be regarded as a related set of parts or components which together form a whole (a key feature of systems thinking is that it treats systems as open).

The general model of organised complexity is that there exists a hierarchy<sup>2</sup> of levels of organisation, each more complex than the one below, a level being characterised by

1. System: A model of a whole entity. When applied to human activity, the model is characterised fundamentally in terms of 'HIERARCHICAL' structures, 'EMERGENT' properties, 'COMMUNICATION' and 'CONTROL'.
2. Hierarchy: The principle according to which entities meaningfully treated as wholes are built up of smaller entities which are themselves wholes.

emergent properties<sup>1</sup> which do not exist at the lower level.

Activities can only be derived from a knowledge of, or at least a presumption of HOW a particular transformation process can be performed in the real world. A danger in creating activity diagrams therefore is to focus attention on some pre-conceived HOW of doing something. Rather attention should be focussed on WHAT needs to be done, and so avoid shallow stereo typed thinking. To overcome this it is useful to think in terms of activities at different levels of resolution, starting at the lowest level of resolution and expanding downwards.

It is in no sense a description of any part of the real world but is simply the structured set of activities which logic requires (in a notional system) to be that defined in the RD<sup>2</sup>.

Modelling becomes a question of asking "What activities, in what sequence, have to occur in order to?".

Because the CM is a model of an 'activity' system its elements will be 'verbs'. The 'technique' of modelling is therefore to assemble the 'minimum' list of verbs covering the activities which are 'necessary' in a system defined in

1. Emergent properties: The principle that whole entities exhibit properties which are meaningful only when attributed to the whole, not its parts. Every model of a human activity system exhibits properties as a whole entity which derive from its component activities and their structure, but cannot be reduced to them.

2. This is difficult to come to terms with.

the RD, and to structure the verbs in a sequence according to logic.

Figure 18 provides a first attempt at an activity diagram for our root definition.



Activity Diagram

Figure 18

It is a matter of judgement as to when to stop model building and move on to a real-world comparison between what exists there and what is in (or is suggested by) the models of systems thought to be relevant to the problem.

Checkland and Scholes<sup>1</sup> have recently revised the seven stage SSM approach and defined new Constitutive Rules. Which provides an account of using SSM over the past decade in problem situations where experiences have led to the recognition of a spectrum of use of SSM from, on the one hand, a formal stage-by-stage application of the methodology (called MODE 1), and internal mental use of it as a thinking

1. Checkland, P and Scholes, J, 1990, 'Soft systems methodology in action'.

mode (called MODE 2).

These new Constitutive Rules introduce the '5Es' into the criteria by which T (T in CATWOE) is judged:-  
**Efficacy** - does the means work ?

**Efficiency** - are minimum resources used ?

**Effectiveness** - does the T help the attainment of longer term goals related to O's expectations ?

**Ethicality** - is T a moral thing to do ?

**Elegance** - is T aesthetically pleasing ?

This new account of SSM (which has been applied in our systems thinking on Guernsey) fits the needs of the present work well.

#### 3.4 The SOGEMS model

The building of conceptual models is based on principles which have been tested in system studies elsewhere<sup>1</sup>.

From the activity diagram, a system diagram is produced in a further design stage in order to model the first Resolution Level (to model what could be), Figure 19.

The RD and the SOGEMS model together confirm that they constitute a mutually-informing pair of statements; what the

1. See Wilson, B, 1984, 'Systems: Concepts, methodologies and applications' for example.

system 'IS' is what the system 'DOES'.

Once this first Resolution Level version of the model has been constructed it can then be used as a basis for further expansion (ie. to Resolution Levels 2 and 3 for example).

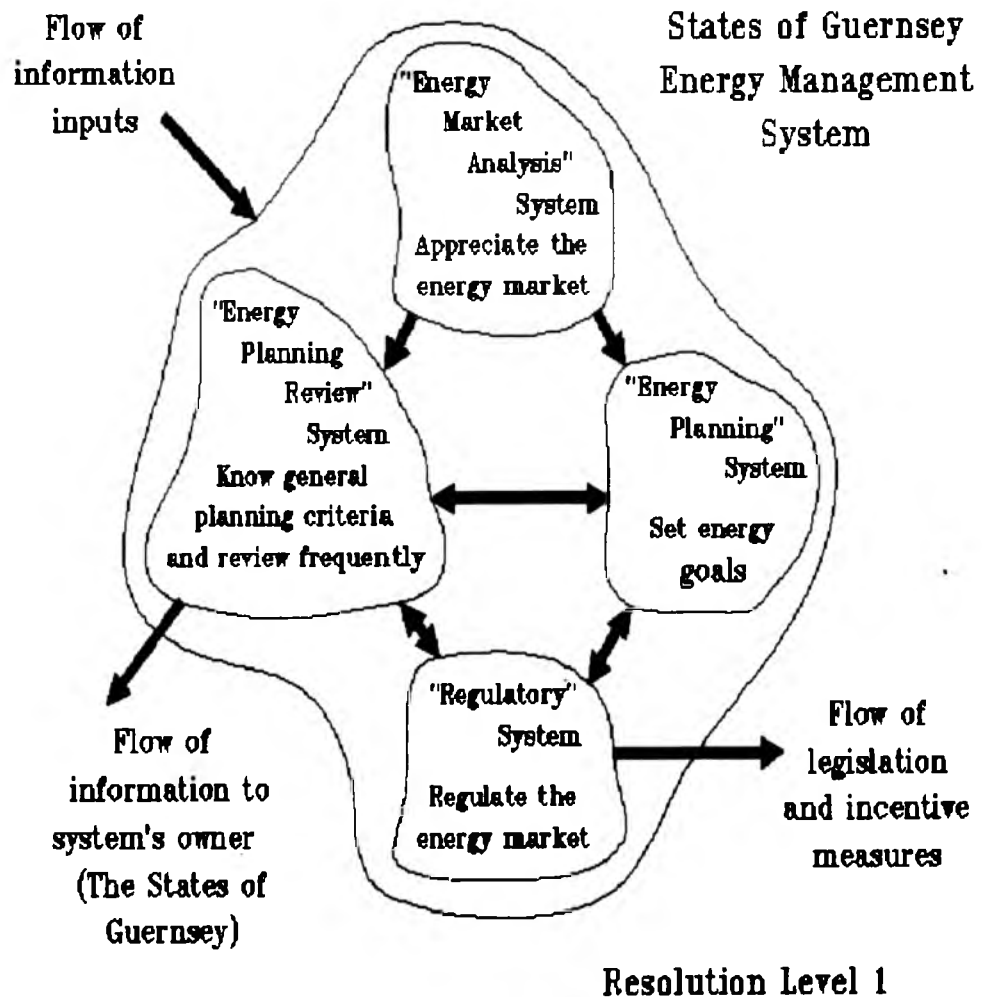
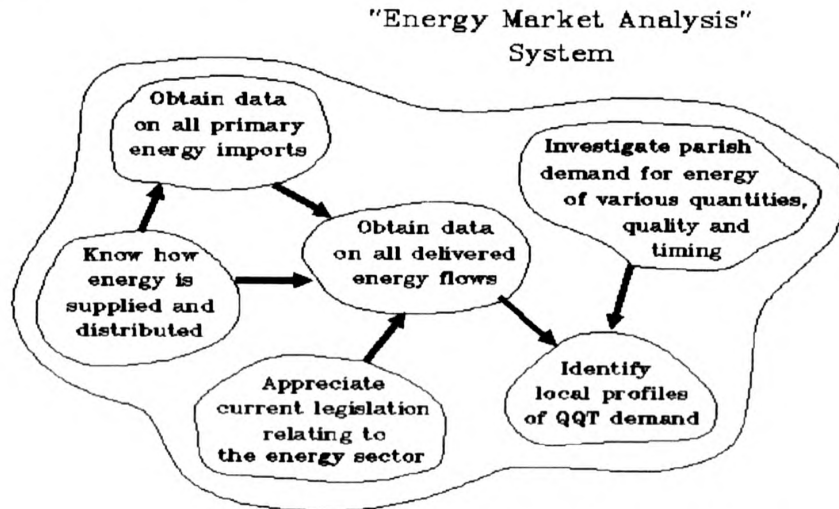

Figure 19

### 3.5 Resolution Levels 2 and 3

The Resolution Level 2 sub-system models are provided in Figures 20 - 23.



Resolution Level 2

Figure 20

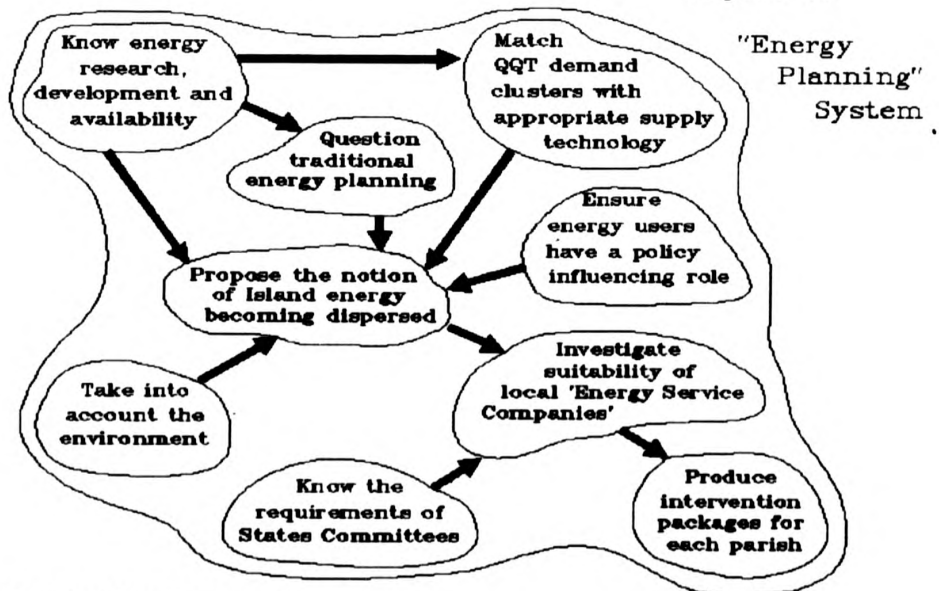

Resolution Level 2

Figure 21

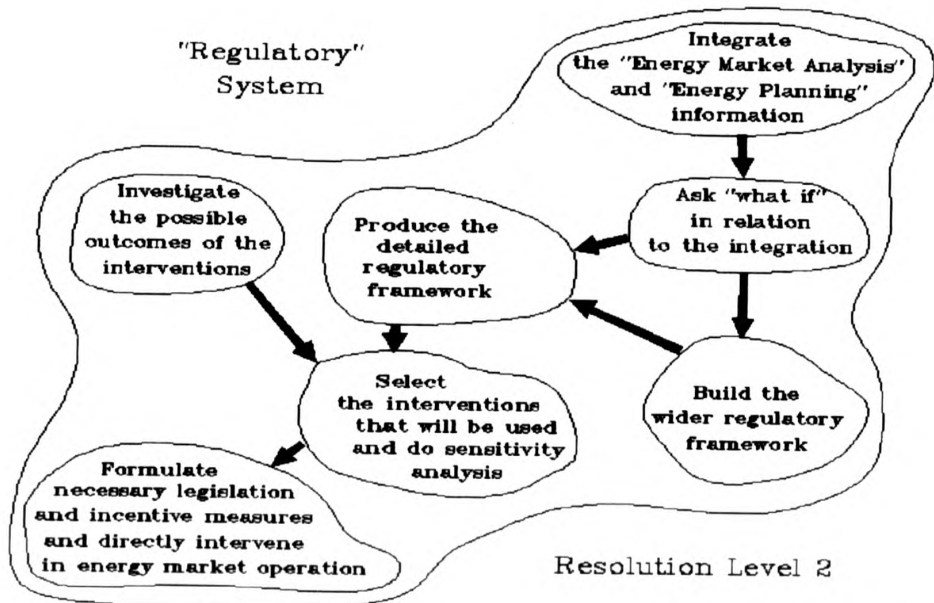

Figure 22

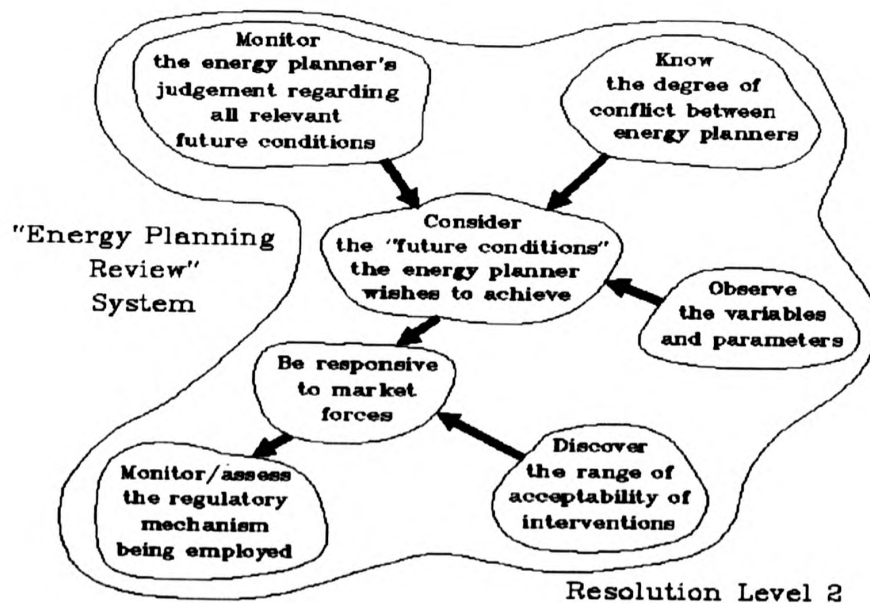

Figure 23

The 'Energy Market Analysis' sub-system model analyses aggregate (historical) energy trends (see Chapter 4<sup>1</sup>), final user fuel trends and system changes (see Chapter 5) and the 'dynamic' context of the system model (ie. energy end-users themselves, see Chapter 6).

The 'Energy Planning' sub-system model deals with the behaviour of the system (see Chapter 8), the QQT matching process of the system (see Chapter 9) and the vectors for, and consequences of changing the system (see Chapter 10). Along with the important costs of changing the system (see Chapter 11).

There is a need here, in moving from the 'Energy Market Analysis' sub-system model to the 'Energy Planning' sub-system model, for 'computer' model building and 'scenario' construction, Figure 24.

**'Energy Market Analysis'  
System**

**Computer  
Model  
Building**



**'Energy Planning'  
System**

Figure 24

1. Historical information relating to the energy sector in Guernsey was not cut and dried. It was ambiguous, sometimes irrelevant and sometimes did not exist at all (reconciliation of aggregate Island energy data was a thankless task).



This is not really methodology but rather the requirement for detailed end-user data collection and its transformation into useful energy planning information.

Chapter 7 is therefore devoted to this computer model building work. Where a commitment is made to modelling different levels of energy service delivery (but these models are not necessarily unique to the declared world view and root definition).

The 'Regulatory' and 'Energy Planning Review' sub-system models (with statutory powers) are necessary for the successful implementation of the SOGEMS model. Such direct intervention in energy market operation is quite legitimate in terms of the Island's self-interest.

Regulatory control is necessary because of the wide range of decisions which often (also indirectly) influence energy decisions (the approval of infrastructure developments for example).

Recommendations for the further work that is required to develop these two other sub-system models (of which Resolution Level 3 proposals are offered in Appendix B) are provided in the Conclusion. All of which is a large (and separate) major task outside the provenance of this thesis.

### 3.6 Comparison with the real world

When systems thinking has been used by others<sup>1</sup> it has basically covered five types of system studies:-

- (1) System design
- (2) Action to improve an ill-defined problem situation
- (3) Historical analysis
- (4) Survey of an area of concern
- (5) Clarification of concepts

Our model building of the energy sector on Guernsey has involved all of these aspects, and provides the basis for a formal energy management system for the Island. It is in no sense a description of any part of the real world (the real world energy situation on Guernsey lacks any strategic energy conservation management).

There are four ways in which we can compare our developed conceptual model with the real world:-

- (1) Informal discussion.
- (2) Formal questioning.
- (3) Scenario writing based on 'operating' the model.
- (4) Try to model the real world in the same structure as the conceptual model.

The method we use is to set the SOGEMS model against

1. For example Watson, R and Smith, R, 1988, 'Applications of Lancaster Soft Systems Methodology in Australia'.

reality by notionally operating the model on paper. The present work reports on the proposed dispersed energy future and compares it with the present (centralised) real world on Guernsey.

Our model offers fundamental change for the organisation of strategic energy conservation management on the Island, but more particularly offers change in:-

- (1) Structure
- (2) Procedures
- (3) Attitudes
- (4) Quality of debate

Chapter 9 discusses the practical implementation of our approach; Chapter 11 its financing and time frame for action and Chapter 12 the acceptance of the concept.

We will show that significant potential exists for reducing oil dependency if the States of Guernsey promotes the implementation of the 'plan, regulate and monitor' phases for development of the energy sector. This will be demonstrated (see Chapter 9).

With an orderly energy investment programme, the monitoring and review phase needs to evaluate the progress of such a programme, updating the information base as it evolves, and adjusting the plan as required. The interplay within the integrated energy management system is the process by which an optimal energy balance may then be achieved.

The formalised thinking of the Resolution Level 3 models are provided in APPENDIX B and have been used both to order our research effort and thesis presentation.

Comprehensive references on 'Systems Thinking' literature are provided in the bibliography.

## CHAPTER 4

### AGGREGATE (HISTORICAL) ENERGY TRENDS

Chapters 4, 5 and 6 provide the 'Energy Market Analysis' sub-system model operated on paper.

The major steps in most forms of energy study involve the necessary collection and later analysis of aggregate (historical) data. Which involves data collection relating to the E-mix, E-consumption and E-pricing, which is the subject of this Chapter. A brief summary of our findings are provided at the end, with the conclusion that shipments of prime fuel into the Island are made particularly onerous by the constraints imposed by St.Sampson's harbour.

#### 4.1 Primary energy imports

##### The E mix and E consumption

In order to examine the pattern of energy demand on Guernsey it is necessary to consider the contribution of the various fuels to the total aggregate demand. Figure 25 provides the primary energy imports into the Island from 1960-90, excluding transport<sup>1</sup>.

Imports of Coal have decreased from 67% of primary energy demand (excluding transport) in 1960 to 14% in 1990. Imports of Fuel Oil (HFO + Gas Oil + Kerosene) have increased from 30% to 77% and LPG from 3% to 9%, over the same period.

1. The Gas Oil component of fuel oil includes Gas Oil used for transport in this Figure.

## Primary energy imports (ex.transport) into Guernsey 1960-1990

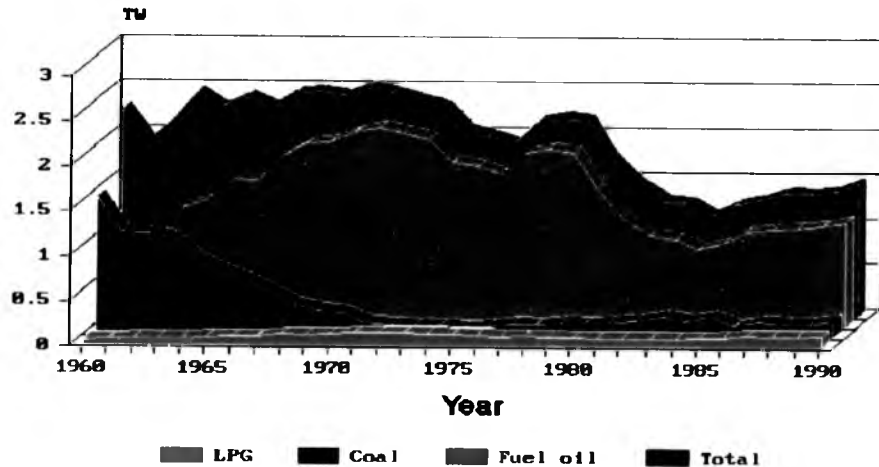

Source: Customs & Excise

Figure 25

Which reveals the extent to which the Island is now dependent on oil, and raises questions of strategic importance<sup>1</sup> (see Section 1.8).

Figure 26 details the (historic) petroleum products of fuel oil imports (HFO + Gas Oil + Kerosene).

Figure 27 the (historic) petroleum products of transport energy imports (Avgas + Avtur + Motor Spirit).

1. Guernsey has no indigenous sources of fuel and has not yet exploited renewable sources of energy as a substitute for oil imports.

**Fuel oil Imports 1977-1990  
(HFO + Gas Oil + Kerosene)**

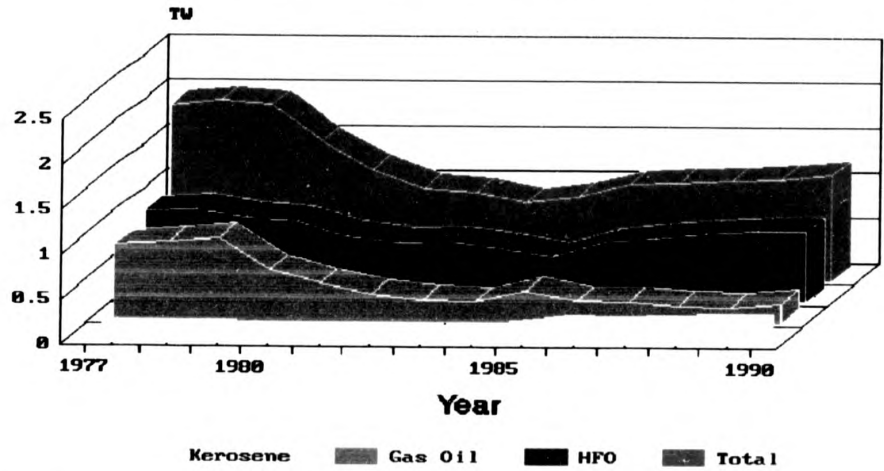

Source: Customs & Excise

Figure 26

**Transport 1965-1990  
(Avgas + Avtur + Motor Spirit)**

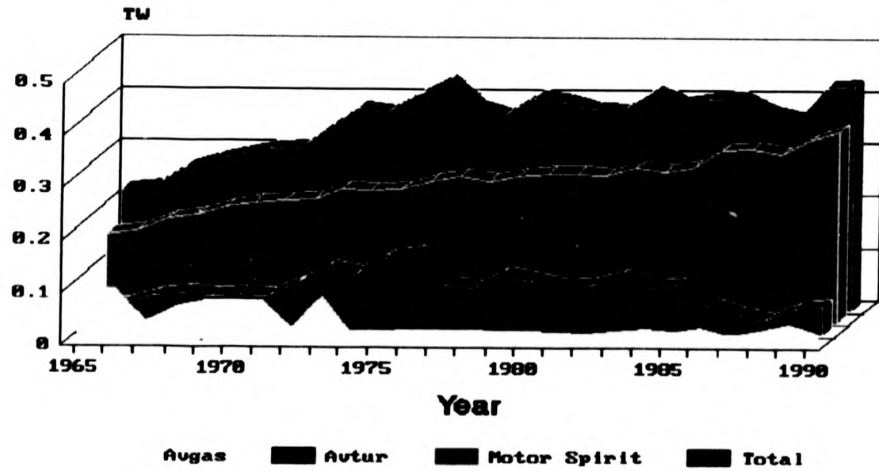

Source: Customs & Excise

Figure 27

### **The importers**

Seven types of oil product are imported into the Island:-

- (a) Kerosene (for domestic central heating)
- (b) Gas Oil (for commercial heating & transport)
- (c) Motor Spirit
- (d) Aviation Gas (for piston engines)
- (e) Avtur Jet A (for turbine engines)
- (f) Heavy Fuel Oil (primarily for electricity generation)
- (g) Liquid Petroleum Gas

Imports and distribution of (a) to (e) are handled by the four oil companies operating in the energy sector (Esso, Total, Shell and BP). Esso operations are organised on Jersey while the other three companies have independent agents on Guernsey.

These petroleum products are supplied to Guernsey mainly from the following British sources:-

- (1) Esso - Fawley in Hampshire
- (2) Total - Immingham on Humberside
- (3) Shell - Thames estuary
- (4) BP - Grangemouth

The agencies supplying the Island energy market are:-

- (1) Esso - Guernsey Petroleum Distributers Limited
- (2) Total - Total (Sarnia) Limited
- (3) Shell - Fuel Supplies (CI) Limited
- (4) BP - Channel Oil Limited



The petroleum product imports for 1990 are described in Figure 28 (total 1729 GW).

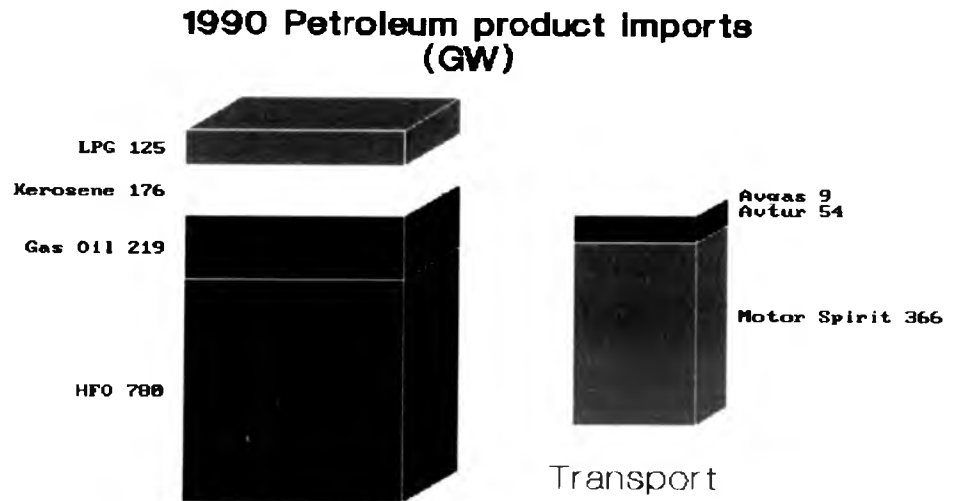

Source: Customs & Excise

Figure 28

All electricity on the Island is generated from oil; the SEB is the only electricity utility and the only importer of product (f), Heavy Fuel Oil, which is mainly imported from BP (Grangemouth).

Import and distribution of (g), Liquid Petroleum Gas, is handled by Kosangas (CI) Limited; Kosangas supply LPG to Gas Energy (CI) Limited, the mains gas supplier on Guernsey<sup>1</sup>. LPG is imported into the Island from Esso at

1. Gas Energy (CI) Limited and Kosangas (CI) Limited are both subsidiaries of the Guernsey Gas Light Company Limited, incorporated 18 February 1911.

Fawley in Hampshire and occasionally from Flushing in the Netherlands.

#### Solid fuel

Six solid fuel products are imported:-

- (a) Housecoal<sup>1</sup>
- (b) Anthracite Stovenuts
- (c) Anthracite Peas
- (d) Anthracite Ovoids
- (e) Charcoal
- (f) Dust

Solid fuel is shipped in bulk by British Fuels Limited (BFL) mainly from the following sources:-

- (1) Goole or Gunness on Humberside
- (2) Swansea
- (3) Amsterdam

BFL is a U.K. wide organisation split into regions. BFL on Guernsey submit their expected demand for the coming year to their headquarters in Harrogate, who then source the required solid fuel.

The British Coal 'Rossington' and 'Bywater' collieries produce the majority of the housecoal used on the Island, the remainder is mainly Colombian and Czech coal from

1. Housecoal (smoky) represents over 70% of the total solid fuel imports into the Island.

Amsterdam<sup>1</sup>. The solid fuel imports for 1990 total 187 GW.

#### Fuel data

The calorific value of a fuel may be considered to be its single most important property. The gross calorific value is the maximum energy that can be obtained from the fuel (which assumes that water vapour formed during combustion is condensed out), and that the heat of vapourisation is recovered (but this is usually not the case in most combustion systems).

The net calorific value is the energy that can be obtained from the combustion of the fuel when the water vapour formed is allowed to escape with the flue gases. In most practical combustion systems no attempt is made to condense the water vapour out and recover its heat of vapourisation (the exception being condensing boilers). In the case of fuel oils the difference between gross and net is approximately 6%.

Typical values for fuel oils on Guernsey are:-

(1) Kerosene, with a typical mean net calorific value of 43.29 MJ/kg and Gas Oil 42.50 MJ/kg. The SEB's Heavy Fuel Oil has a mean net calorific value of 40.79 MJ/kg and Product 469<sup>2</sup> from Total 40.86 MJ/kg.

1. The housecoal imported into the Island has a degradation rate of some 6%.
2. A heavy fuel oil imported by Total, mainly supplied to the horticultural/vinery sector.

(2) Both Propane and Butane are imported into the Island with typical net calorific values of 46.30 MJ/kg and 45.80 MJ/kg respectively.

(3) Coal defies any universal classification system, and is a vast subject which comprises a large number of classification systems. The most important variable in the nature of coal is its rank<sup>1</sup>. Volatile matter, calorific value and carbon content (singly or in combination) is used to divide coals into major classes or groups on the basis of rank.

The rank of housecoal on Guernsey is primarily 702, high-volatile, weakly caking coal (smoky) with a typical gross calorific value of 30.60 MJ/kg and net calorific value 29.65 MJ/kg.

The approximate conversion equivalents used in the present work are provided in APPENDIX A.

#### **Financial accounts of importers**

The oil company agencies supplying the market are each incorporated in Guernsey but little can be revealed with regard to their financial position. Under the Companies Law on the Island the identities of the beneficial owners are not required to be disclosed, and also no accounts need to

1. See Harker, J.H and Backhurst, J.R, 1981, 'Fuels and energy' or Sarkir, S, 1990, 'Fuels and combustion' for example.

be filed<sup>1</sup>.

Only two agencies supplied fuel oil throughout the 1960-1970 period (Shell and Esso), along with the SEB (Gas Oil). Total entered the market in 1972 when a joint marketing agreement between Shell and BP in the U.K. ended; BP was incorporated in 1977. Which led to the present arrangement between Shell and BP where BP operates only a 'dry' depot on Guernsey, and purchases all its oil products from Shell.

Two types of oil are used for electricity generation; Heavy Fuel Oil imported by the SEB, and Gas Oil purchased from local agencies. The latter now accounting for only a small percentage of the SEB's total oil consumption<sup>2</sup>. In order to attempt to assess the financial performance of the SEB a comparison is made with the Jersey Electricity Company Limited, Manx Electricity Authority and Alderney Electricity Limited for the year 1988/89.

The sales/capital employed ratio is provided in TABLE 4.1, which relates to the invested funds each organisation employed to attain their sales in 1988/89.

1. An income tax paying company has only to produce accounts to support its tax return. This information is then also used in the compilation of Guernsey's GNP figures (see Section 2.2).
2. The SEB began importing Heavy Fuel Oil into the Island in the late 1970s for their new (large) slow-speed diesels.

**TABLE 4.1 - Sales/capital employed<sup>1</sup> 1988/89**

		Sales/Capital
<b>Guernsey:<sup>2</sup></b>		
Consumers:	25,611	£13,878,200
Units billed :	199,600,000 kWh	----- = 0.44
Av.price/kWhe:	6.95p <sup>3</sup>	£31,642,171
<b>Jersey:<sup>4</sup></b>		
Consumers:	36,600	£21,152,000
Units billed :	383,750,000 kWh	----- = 0.37
Av.price/kWhe:	5.51p	£56,968,000
<b>Isle of Man:<sup>5</sup></b>		
Consumers:	32,337	£14,799,000
Units billed :	198,151,474 kWh	----- = 0.42
Av.price/kWhe:	7.47p	£35,494,000
<b>Alderney:<sup>6</sup></b>		
Consumers:	1444	£566,062
Units billed :	4,328,758 kWh	----- = 0.77
Av.price/kWhe:	13.07p <sup>7</sup>	£731,496

1. Historic cost accounting.
2. Black, Geoghegan and Till, 15 May 1989, 'States of Guernsey Electricity Board - Auditors Report - 1 April 1988 to 31 March 1989'.
3. Note that average unit prices do not include standing charges.
4. The Jersey Electricity Company Limited, 1988/89, 'Annual Report and Accounts for the period 3 October 1988 to 1 October 1989'.
5. Manx Electricity Authority, 1989, 'Annual Report and Accounts for 1988/89'.
6. Alderney Electricity Limited, 1988, 'Annual Report and Accounts for 1988'.
7. Alderney Electricity import and supply Gas Oil and Kerosene as well as supply electricity. The price of electricity is set at a high level in order to encourage domestic energy consumers to purchase Kerosene (a cheaper and more energy efficient form of space heating). Personal communication - Buggy, J, 25 June 1992, General Manager, Alderney Electricity.

There is no set level for the sales/capital employed ratio and it is used here only as a comparison of similar very small island (centralised) electricity companies. The return on investment for the SEB in 1988/89 was 13.4% (12.5% in 1989/90).

The Guernsey Gas Light Company Limited has become something of a conglomerate over recent years with gas supply making only a small contribution to turnover,

TABLE 4.2.

TABLE 4.2 - Guernsey Gas Light Company Limited  
Contribution to turnover - 1989

Gas	3.4%
Motor trade/retail fuel	75.0%
Fuel distribution	18.2%
Rents	1.7%
Other	1.7%
	-----
	100.0%
	-----

$$\text{Sales/capital employed} = \frac{\text{£82,479,000}}{\text{£22,732,000}} = 3.63$$

BFL is incorporated on the UK mainland (not in Guernsey) with British Coal (before privatisation) having over 50% stake in the Company; the remaining equity participation comprise bank and employees.

#### 4.2 Primary energy pricing

##### Petroleum product prices:

The price at which oil products are bought from U.K. suppliers tend towards a level which is related (via a given

mark-up) to the spot market price at Rotterdam<sup>1</sup>.

In the case of most oil companies operating on the Island, the price at which oil products are sold is primarily determined by the parent company on the U.K. mainland. A degree of responsiveness to local market conditions are provided both by adjustments made centrally by the parent and by way of a limited amount of flexibility given to the local agent. In the case of Total (whose Guernsey agents organise the purchase and shipping of oil products from the refinery themselves) there may be more scope for discretion at the local level.

The SEB have in the past had annual contractual agreements with BP on the mainland to ensure that the power station has sufficient supplies of HFO at all times for the generation of electricity<sup>2</sup>.

In the SEB 1990/91 financial year their fuel cost was £3,407,000, with fuel consumption of 52.7 million litres of HFO and 0.57 million litres of Gas Oil; which gives an approximate fuel cost of some 6.4 pence/litre.

We can compare this with the Energy Information Centre

1. Guernsey Evening Press headline of the 15 August 1990 notes "the trouble with oil prices is not just the Gulf crisis, they are always up or down".
2. Guernsey Evening Press, 8 March 1982, reported the then General Manager of the SEB remark "of course we realise that we could buy oil at spot prices in Rotterdam much cheaper than from the U.K. domestic market at present, but above all is the question of security of supply. This is particularly important in times of oil shortages".



'Price evaluation and market intelligence (1990) Report', which gives the U.K. regional HFO average price along with the Rotterdam spot market alternative for 25 July 1990 (well before Iraq invaded Kuwait), TABLE 4.3.

**TABLE 4.3 - UK regional HFO average price (pence/litre)**

Region	25 July 1990
South East	5.75
Western	5.80
Midlands	5.53
Eastern	6.08
North East	6.14
North West	5.61
Scotland	5.72
Northern Ireland	6.29
<b>Rotterdam spot alternative</b>	<b>5.98</b>

Taking into account freight costs, the delivered HFO price on Guernsey (1990) suggests that it may have been BELOW the Rotterdam spot alternative.

#### **LPG prices**

The import of Propane or Butane is determined by their respective prices. During 1990 prices favoured the use of Propane and therefore mains gas output was mainly Propane based.

#### **Coal prices**

TABLE 4.4 provides a breakdown of the pricing structure

of house Coal, based on a shipment from Swansea to Guernsey (5 November 1990) of 1164 Tonnes (40-80mm in size) carried by the M.V. CORNET.

**TABLE 4.4 - British Fuels Limited - House Coal (£/tonne) (1990)**

f.o.b.	65.750	(48%)
Freight	7.950	
Insurance	0.076	
C. Liability	0.060	
Cartage	0.310	
Stevedoring	1.508	
Craneage	0.657	
Ocean losses	-	
c.i.f.	76.311	
<b>Marketers margin</b>	<b>41.689</b>	<b>(31%)<sup>1</sup></b>
Duty	-	
Duty Paid Price	118.000	
Retailer's margin	18.000	(13%)
<b>Retail Price</b>	<b>136.000 (40 * 25kg Bags)</b>	<b>(100%)</b>

#### Freight costs

Freight costs affect all aspects of energy on Guernsey. The cost of shipping oil products around the British Isles (relating to one way journeys of between 400 and 1000 miles) has been estimated (for a shipment of 1500 tonnes) to involve freight costs of approximately £10,000 (1990 prices)<sup>2</sup>. This implies a per litre freight cost of around 0.56 pence; the cost of transporting motor spirits and kerosene is normally slightly less than this, while that of

1. A high-margin business. Out of the marketer's margin, costs are incurred in bagging and storing at the BFL coal yard.

2. See Armstrong, H, Johns, G, Johns, J and Macbean, A, 1990, 'Energy prices on the Isle of Man' for example.

shipping heavier oils would be slightly more.

Costs associated with demurrage, insurance, import dues and losses through degradation are likely to add a further one third of a penny per litre to the total transport cost<sup>1</sup>.

#### Duty charged on energy imports

The only intervention in the energy market by the States of Guernsey is in the form of excise duty levied on motor spirit ONLY. The rates of duty are much lower than on the U.K. mainland, TABLE 4.5.

TABLE 4.5 - Rates of duty (pence/litre)  
(28 November 1988)

Fuel	UK	Guernsey
Leaded M.S.	20.44	6.20
Unleaded M.S.	17.72	5.00

### 4.3 The supply and distribution of energy

#### Primary energy transportation

As described earlier, BP operate a 'dry' depot on Guernsey and purchase their oil from Shell, who handle the arrangements for both shipping and storage. The oil products sold by BP are not of the same specification as those sold by Shell. Advanced petrols are dosed with additives, Gas Oil

1. For references on sea freight see:  
Journal of Transport, Economics and Policy, 1985, 'The optimal ship size' or

Journal of Transport, Economics and Policy, 1985,  
'Economies of trade density in liner shipping' or

Review of Economics and Statistics, 1978, 'Economies of scale of general cargo ships'.

is doped to produce advanced diesel etc. In 1990 Shell made 25 shipments of combined cargo, Esso made 17 shipments and Total 25 shipments to the Island.

The SEB made approximately 23 deliveries<sup>1</sup>, the frequency of delivery is greater in the winter than in the summer. LPG (Propane and Butane) is shipped to Guernsey by Kosan Tankers (Denmark).

The problem with importation is that the size of the tankers used for shipping are determined by the severe constraints imposed by St.Sampson's harbour. Which is a 'tidal' harbour and limits the size of tanker making the delivery.

In 1990 BFL imported solid fuel in bulk vessels, TABLE 4.6. (with an annual contract for shipping negotiated).

**TABLE 4.6 - 1990 annual coal shipments**

<b>Solid Fuel</b>	<b>Shipments</b>	<b>Tonnes</b>
Housecoal	17	18,569
Anthracite Stovenuts	4	3,200
Anthracite Peas	2	1,600
Anthracite Ovoids	2	1,600
	-----	-----
	25	24,969

**Storage facilities/capacity available**

Bulk storage capacity for the primary energy importers at St.Sampson's harbour is shown in Figure 29.

1. Size of tankers 2000-2500 tonnes.

# Bulk Storage Facilities (GWh)

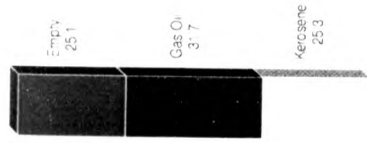

# Esso/Petroleum Distributors



Transport

# Total (Sarnia) Limited



Transport

# Shell/Fuel Supplies (CI) Limited

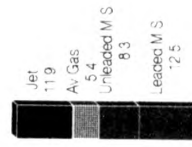
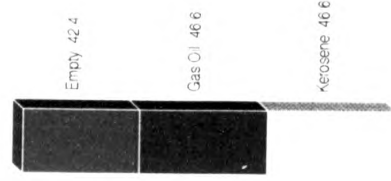

Transport

Figure 29

Source: Health & Safety Exe.

Airport storage of Avgas and Avtur is 0.3 GWh and 1.7 GWh respectively.

The SEB have a separate storage capacity of 135.7 GWh for Heavy Fuel Oil (in six storage tanks located within the power station site at St.Sampson's harbour) and also the capacity to store 12.7 GWh of Gas Oil.

Storage of LPG on the Island has been very limited; maximum storage capacity of 11.8 GWh (8.9 GWh at St.Sampson's harbour and 2.9 GWh at St.Peter Port; with the storage facilities at St.Peter Port filled by pumping gas from St.Sampsons). In 1990 a time charter had to be negotiated between Guernsey Gas and Kosan (Denmark) to ensure that a tanker was available at all times. The acute storage problem was emphasised just before Christmas of 1989 when LPG stocks dropped to just four days, during a period of mild weather<sup>1</sup>.

BFL import coal into St.Sampson's harbour and then transfer it to the nearby coal yard for storage (and then pack it into 25 kg polythene bags). Most of the bulk storage is under covered sheds where 41.1 GWh can be stored. A further 22.4 GWh of bulk coal is kept under polythene sheet outdoors, with 15 GWh of ready packed 25kg bags usually held in stock<sup>2</sup>.

1. A new LPG storage facility was commissioned in 1991 which added 5.6 GWh to existing capacity.

2. Annual calorific deterioration of stocks is considered to be negligible.

The constraints imposed by St.Sampson's harbour impose extra transport costs on importers due to the large number of shipments that have to be made to the Island.

With the harbour also being tidal, deliveries are only possible every two weeks and the draft of vessels entering the harbour also limit the size of ships being used<sup>1</sup>. A strategic energy conservation approach to the energy problem would reduce the number of shipments into the Island, thus improving this situation; this will be demonstrated (see Chapter 9).

#### Energy distribution networks

##### Oil products

Delivery of oil products from the bulk storage facilities to each economic sector is undertaken by the oil companies themselves. With a maximum width restriction of 2.2 metres for vehicles using Guernsey roads, which requires road tankers to be adapted to suit the road network. The vehicles currently in use hold approximately 110 MWh of fuel and are seen regularly to be making deliveries throughout the Island.

Most of the Heavy Fuel Oil imported by the SEB is used to generate electricity, but a small quantity is sold to the

1. A very high capital investment would be required for a deep water port facility. Representatives of the energy agencies have indicated that current trends in shipping make such a facility a matter of high priority. The number of ships available to importers in the present situation is diminishing and this has the effect of raising overheads for importers of fuel, making the Island even more vulnerable to breaks in supply.

horticultural sector through a distribution agreement with Esso. Esso load fuel from the SEB storage tanks and then deliver direct to Island growers.

### **Electricity**

The power station site at the Vale has historically supplied the whole Island, at a system voltage of 11kV.

During the last few years though the SEB have thought it necessary to install a 33kV transmission network. After transmission the voltage is stepped down from 33kV to 11kV and then distributed via the local 11 kV high voltage cable network.

The voltage is then further reduced for use in all sectors of the Island economy. The network is so designed as to maintain the supply voltage and frequency within the working range of standard a.c. electrical equipment and appliances.

### **Gas distribution**

The north, east, south east and north west areas of Guernsey are supplied with mains gas (some 60% of the Island) which consists of a mixture of LPG and air. Many of the gas mains are cast-iron (although there is a limited amount of steel and P.V.C and, more recently, medium-density polyethelene). Significantly, nearly all of central St.Peter Port used the older cast-iron pipework.

Bottled gas is also supplied to ALL of the Island by Kosangas, who deliver to customers mainly by lorry (but



domestic consumers can also collect cylinders from their depot).

### Coal

Island delivery of coal is arranged by franchised lorry drivers. In addition, BFL deliver domestic coal themselves to some 44 retail outlets (garages, supermarkets etc) throughout the Island, with a small proportion of domestic sales taking place at the coal yard itself (BFL also arrange deliveries to 10 large growers).

### The costs of supply and distribution

#### Oil products

The cost of road tanker delivery of oil products from storage facility to end-user is INCLUDED in the per litre purchase price of the fuel. This inclusive charging system is used by each of the four agencies on the Island.

For example, a typical 900 litre load of Kerosene delivered anywhere on the Island (1992 prices) is provided in TABLE 4.7.

**TABLE 4.7 - 900 litre delivery of Kerosene (1992 prices)**

TOTAL (Total (Sarnia Ltd))	15.65p/L (1.48p/kWh)
SHELL (Fuel Supplies (CI) Ltd)	14.65p/L (1.38p/kWh)
ESSO (Gnsy Pet. Distributers Ltd)	14.35p/L (1.35p/kWh)
BP (Channel Oil Ltd)	14.25p/L (1.34p/kWh)

### Electricity

Transmission and distribution costs contribute significantly to the total cost of providing an Island wide

electricity service. In the SEB 1990/91 financial year 25% (£1.25 million) of their total capital expenditure was spent on the transmission and distribution network and £1.3 million on operations and maintenance.

Total fixed assets (current cost accounting) for 1990/91 was £62,343,000. Of this £23,257,000 was associated with the transmission and distribution network (cables, plant and equipment etc; but does not include land, buildings and vehicles).

The SEB suggest that the cost of their centralised electricity generation<sup>1</sup> is to a large extent determined by the cost of fuel burnt in their Vale power station,

TABLE 4.8.

TABLE 4.8 - Cost of SEB generation for a typical month of 1992 for example (Electricity generated 24,154,100 kWh)

	Pence/kWhe
B Station	0.065
Gas Turbine	0.007
C Station	0.135
Fuel Oil Treatment	0.010
Site	0.040
Vehicle Maintenance	0.000
Steam Raising	0.026
Indirect Exp. (inc.Dep.)	0.766 <sup>2</sup>
Fuel	1.654
	-----
	2.705

1. States Electricity Board, 1992, 'Monthly generation cost reports'.

2. Great care however needs to be taken when making comparisons with the SEB and the costs of other new generation/cogeneration sources. The SEB figure may have largely written-off costs. This is discussed in Chapter 11.

Important is that the major component of the cost of a unit of centralised electricity delivered to the final-user is related more to the transmission/distribution network.

Electricity end-users on Guernsey pay 2.5 times as much to have electricity delivered to them from the centralised power station at Vale as to generate it (9.37p/kWhe [see TABLE 4.9] as against - 2.705 p/kWhe, 1992 prices)<sup>1</sup>.

#### Gas

The contribution of gas sales to turnover of the Guernsey Gas Light Company Limited is only small, but indications are that in terms of profitability the contribution may be greater. Yet the costs associated with the operation and maintenance of the storage facilities, gas producing plant and mains gas network may be high.

#### Coal

As described earlier, Island delivery of domestic coal is arranged by ten franchised lorry drivers. TABLE 4.4 recorded the retailer's margin as £18.00 per tonne (13%), out of which all their costs must be paid.

#### 4.4 Delivered energy pricing

Both electricity and gas are secondary fuels on

1. We will later show that electricity generation (and consequent transmission and distribution) from the centralised power station also accounts for the major proportion of Island conversion, transmission and distribution losses.

Guernsey and are not in a position to compete with the primary fuels. These form their feedstocks, and the value added by the manufacture of the secondary fuel has to be absorbed. A comparison of the typical tariff costs in the Guernsey domestic energy market for 1992 are provided in TABLE 4.9<sup>1</sup>.

**TABLE 4.9 - Typical tariff costs in the domestic energy market (9540 kWh/annum, including standing charges - 1992)**

Fuel	(pence/kWh)
Gas <sup>2</sup>	5.56
Electricity <sup>3</sup>	9.37 (Economy 7 - 4.37)
Oil <sup>4</sup>	1.48
Coal	1.95

A domestic consumer on Guernsey using mains gas pays over twice as much as a similar consumer on mainland Britain or in most other European countries<sup>5</sup>.

A comparison of Guernsey electricity charges also

1. These prices will be used for comparison with dispersed power and energy futures later (1992 taken as the base year for all cost comparison purposes).
2. Gas Energy (CI) Limited, 1992, 'Gas pricing data'.
3. States Electricity Board, 1992, 'Annual Report and Accounts 1991/92'.
4. Typical 900 litre kerosene delivery (see TABLE 4.7).
5. See British Gas, 1990, 'Techno-economic feasibility study for Gas Energy (CI) Limited' - Phase Two Report and British Gas, 1989, 'Techno-economic feasibility study for Gas Energy (CI) Limited' - Interim Report.

indicates that the standard domestic tariff is 20% higher (standing charge 10% higher); Economy 7 tariff 44% higher (standing charge 0.4% higher) than the average U.K. Regional Electricity Company in 1992.

An examination of these various domestic energy tariffs on the Island reveal how competitive the end-user pricing is. This competition appears to be very tight between gas and electricity where the electricity Economy 7 night tariff undercuts the standard gas tariff for example.

At the present time oil currently enjoys a low price in the end-user market (but of course is always subject to economic and political influences on its price). It is priced so low as to make competition with it very difficult<sup>1</sup>.

With respect to energy for transport, there are 41 garages on the Island selling motor spirit and diesel, the majority are tied to one of the oil agencies. The price of motor spirit is the same at all garages (but this is not the case for diesel fuel). The retailer has a margin of around 20%, which is considerably higher than on the UK mainland, and explains why there are so many garages.

Typical tariff costs in the transport energy market for 1992 are provided in TABLE 4.10.

1. Various discounts are also available for large commercial (non-domestic) consumers of oil products, which can amount to over 10% of the listed price.

**TABLE 4.10 - Typical tariff costs in the transport energy market (1992)**

<b>Fuel</b>	<b>(pence/kWh)</b>
Motor Spirit	3.02
Gas oil (diesel)	1.48
Avtur	2.69
Avgas	2.98

**SUMMARY**

(1) In 1990 petroleum product imports into the Island were 1729 GW and solid fuel imports 187 GW.

(2) Freight costs affect all aspects of energy on Guernsey, with more than 120 oil and coal shipments made to the Island in 1990. The constraints of St.Sampson's harbour are particularly onerous.

(3) Transmission and distribution of electricity contribute significantly to the total cost of delivered electricity.

(4) Gas and electricity tariffs on the Island are higher than on the U.K. mainland.

(5) Currently oil is at a low price in the end-user market, so low as to make competition with it very difficult.

## CHAPTER 5

### FINAL USER FUEL TRENDS AND SYSTEM CHANGES

A complete accounting of energy flows on the Island is now provided in this Chapter, from original supply through conversion processes to economic sectors<sup>1</sup>.

It leads to the conclusion that there has been a threefold increase in energy losses from centralised electricity generation from 1964 to 1990 (and they are increasing). Present Island institutions (and non-intervention in the energy sector) have been unable to reduce or eliminate these losses.

#### 5.1 Delivered energy flows

The collection and assembly of a wide variety of aggregate raw energy data has been required during the course of the present work. Important sectors are not elsewhere covered by available statistics.

A particular problem at the sectoral level is the failure of official Island statistics to specify energy sales by final end-use categories. Formal inspection of the sales ledgers of most centralised energy suppliers was impossible for commercial reasons, however, co-operation on

1. Later (Chapter 6), a disaggregated approach is adopted which has the advantage that end-user activities become far more identifiable.

an informal basis enabled this problem to be resolved<sup>1</sup>.

British Gas<sup>2</sup> and the States Technical Services Department<sup>3</sup> have in the past attempted to quantify energy flows to economic sectors on Guernsey. However, the data collection and analysis in the present work suggests that two significant errors exist in these earlier works (which are corrected here).

First, a large misallocation of Gas Oil was evident which does not accurately represent the Gas Oil (diesel) component of the transport sector. Second, the significant losses with respect to mains gas have not been correctly identified as a loss but identified as part of the mains gas end-use demand.

#### Heavy Fuel Oil Market

Figure 30 describes the energy flows associated with the importation of Heavy Fuel Oil in 1990 (Product 469 is included within this HFO classification).

The two markets for HFO are electricity generation (559 GW) and horticulture/vineries (55 GW). Product 469

1. Access to large energy end-user premises for the purposes of energy data collection (in order to supplement existing data by direct research work) was undertaken under the auspices of the SEB (see Chapter 6).
2. British Gas, 1990, 'Techno-economic feasibility study for Gas Energy (CI) Limited' - Phase Two Report and  
British Gas, 1989, 'Techno-economic feasibility study for Gas Energy (CI) Limited' - Interim Report.
3. States of Guernsey Technical Services Department, 1988, 'Energy flows'.



Heavy Fuel Oil  
1990

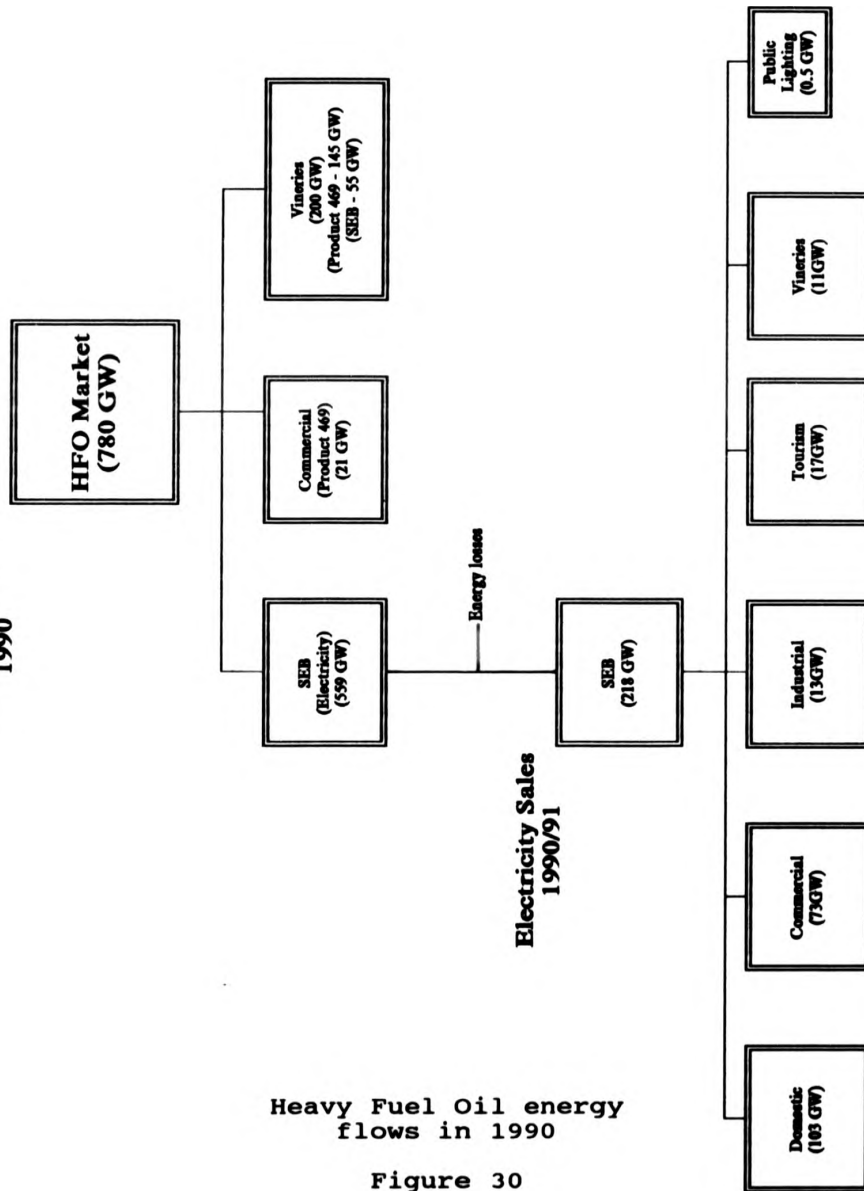

is used in horticulture/vineries (145 GW) and the commercial sector (21 GW). The principal advantage of Product 469 over HFO is that there is no requirement for trace heating; the principal disadvantage is it's high sulphur content.

The 1990 annual report of the SEB indicated end-user electricity (sectoral) demands to be: domestic (103 GW), commercial (53 GW), industrial (40 GW), tourism (13 GW), vineries (8 GW) and public lighting (0.5 GW). Regardless when investigating the SEB's database it became clear that the sector described as 'industrial' did not wholly consist of industrial consumers<sup>1</sup>.

Within the database, the industrial sector is described as the listing of all 'Maximum Demand' consumers (approx 100; who have electricity demands in excess of 50 kWe). A detailed investigation of the database revealed that the description of the sector called 'industrial' is very misleading<sup>2</sup>, the ACTUAL electricity consumers in this category are: 11 tourism, 7 vineries, 46 commercial/public buildings and only 36 industrial.

The end-user sectoral demands for electricity should therefore be: domestic (103 GW), commercial (73 GW), industrial (13 GW), tourism (17 GW), vineries (11 GW) and

1. The industrial/manufacturing base in Guernsey is very small.

2. Published electricity (sectoral) data is often the only source of reasonably reliable consumption estimates. In Guernsey, forecasts of future electricity growth have even been made by external consultants using such erroneous data. See Ewbank Preece Limited, 1989, 'Review of generation development' for example.

public lighting (0.5 GW), and we use this in the present work.

Heavy Fuel Oil for electricity generation represents 41% of primary energy imports in 1990 (excluding transport).

#### Gas Oil Market

Figure 31 describes the energy flows associated with the importation of Gas Oil, Motor Spirit, Avtur and Avgas in 1990.

The present work indicates that 52% of Gas Oil imports were used for transport end-uses in 1990 (114 GW); marine (60 GW) and road (54 GW)<sup>1</sup>.

The remainder is primarily used for space heating; commercial/tourism/industrial (68 GW), domestic (10 GW) and horticulture/vineries (18 GW).

1. Misallocation of Gas Oil to other sectors is difficult to quantify; for example industrial consumption when it is in fact for freight transport etc.

Detailed research carried out on the Island in 1992 (Brown, R.P, Fielden, D and Jacques, J.K, 'Electric vehicles: An alternative transportation system for Guernsey'- a University of Stirling internal report) quantified the Gas Oil market in detail. The Writer directing the research effort and supervising the field work, locally.

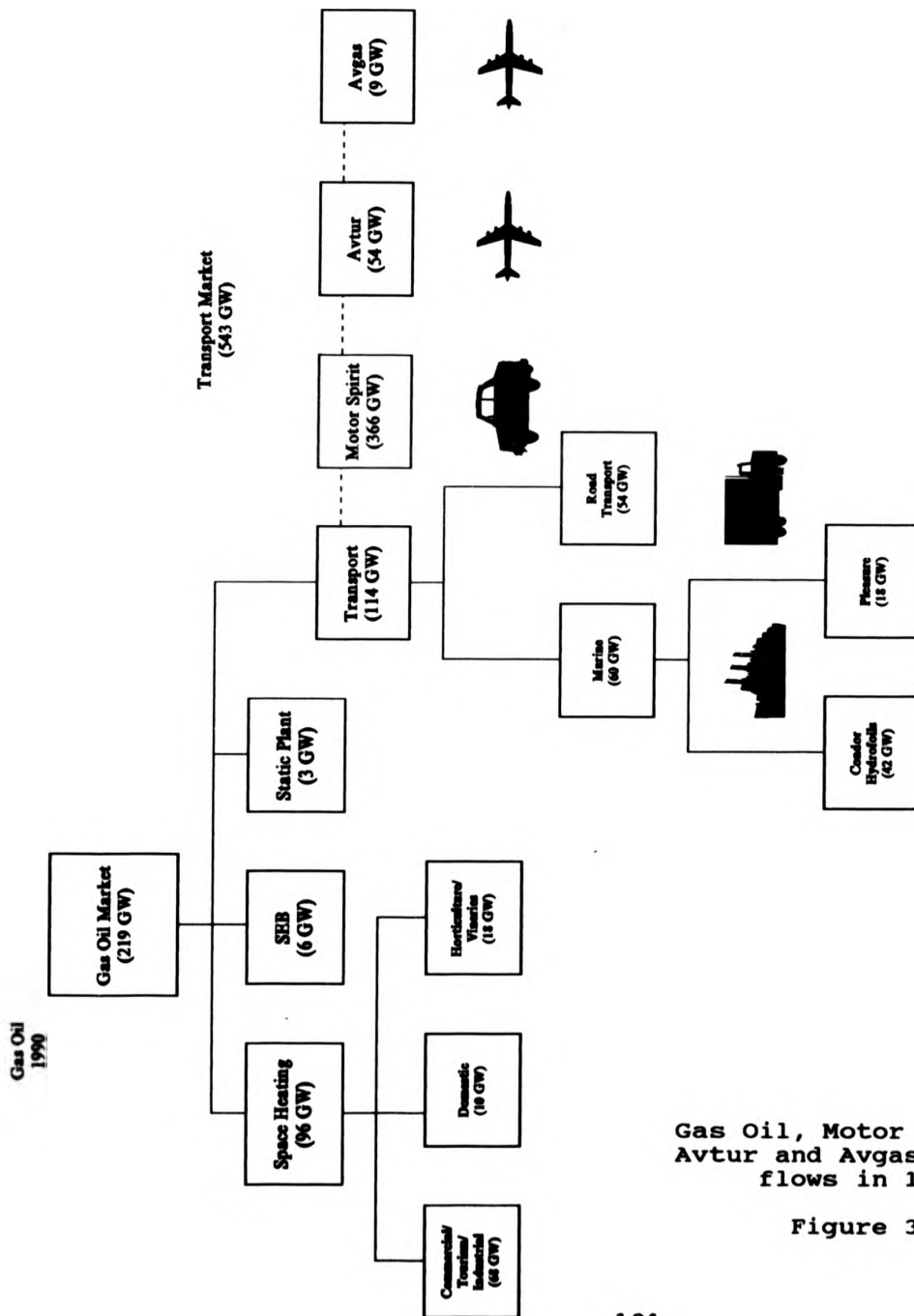

Gas Oil, Motor Spirit, Avtur and Avgas energy flows in 1990

Figure 31

**Kerosene/LPG Market**

Figure 32 describes the energy flows associated with the importation of Kerosene and LPG in 1990.

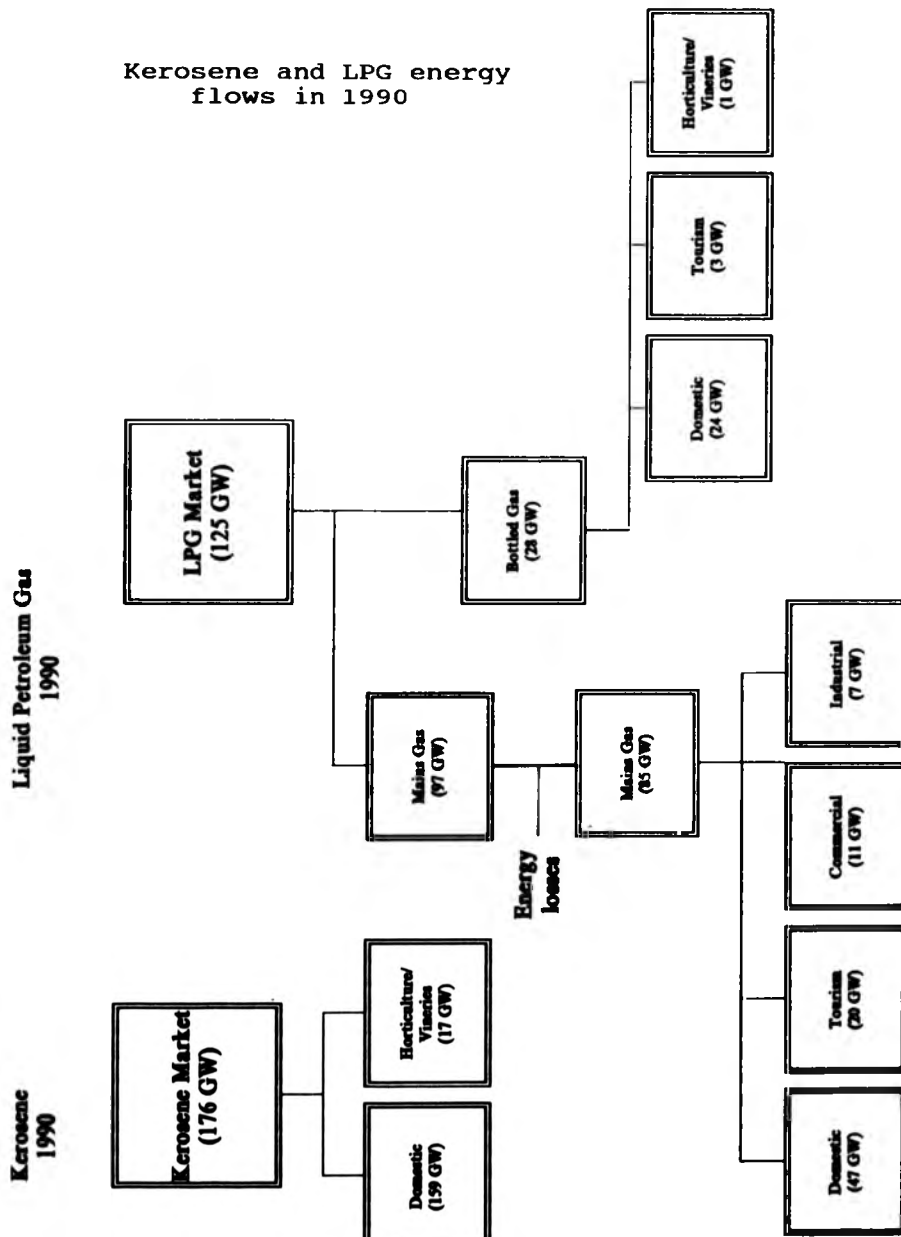

Figure 32

### The coal market

Figure 33 describes the energy flows associated with the importation of Coal in 1990.

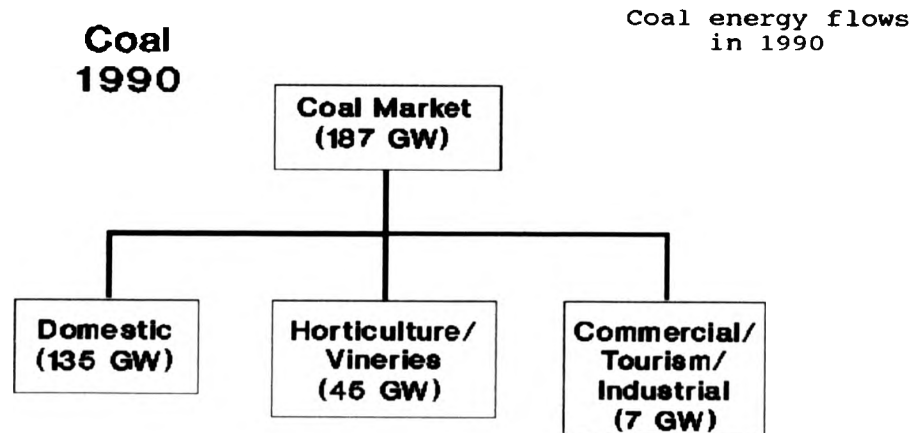

Figure 33

### Comparisons of energy use

All comparisons of energy use have to face the problem that different fuels and electricity are neither consumed nor supplied with the same efficiencies or conversion losses. Therefore to compare sectoral energy use by the simple totals of fuels and electricity consumed can be very misleading.

One solution is to make use of comparisons in terms of useful energy, by this we mean the thermodynamic work 'availability' or energy Quality<sup>1</sup>.

1. Others have researched the quality and work potential (exergy) of energy systems, particularly in relation to very small Scottish island communities, using both conventional and renewable resources. See Pinney, A.A, 1987, 'Planning energy systems for small, rural communities (including economic, technical and thermodynamic criteria)' - PhD thesis [University of Strathclyde] for example.

The other solution, and the one we use in the present work, is to convert each type of energy to its primary energy equivalent and total these. Each energy consuming sector is charged with its fair share of 'overhead' due to energy conversion and distribution losses.

Figures 34 and 35 provide these energy flows for the Island both with and without this 'overhead'.

**Energy flows to economic sectors 1990  
With 'overhead'**

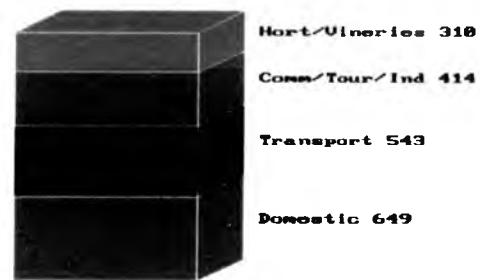

Total = 1916 GW

Figure 34

**Energy flows to economic sectors 1990  
(Total = 1916 GW)**



**Without 'overhead'**

Figure 35

The domestic sector (649 GW) has the largest energy demand on Guernsey, followed by transport (543 GW), commercial/tourism/industrial (414 GW) and horticulture/vineries (310 GW).

#### **Sizable losses**

What is clearly evident from the supply/demand balances and the charging of this 'overhead' is that the electricity conversion process + transmission and distribution of electricity (and also gas) are responsible for high losses.

It is questionable whether Guernsey can afford such high losses, particularly in a small island situation where all energy requirements are imported (with difficulty, see Section 4.3). What we need to ask is whether the imported fuel equivalent to these losses can be saved through alternative cogeneration and transmission schemes.

Distributed cogeneration may potentially offer a reduction in prime fuel imports for this very small (densely populated) Island. Its relevance and optimality in the light of long and medium term economic evaluations though need to be verified (see Chapter 11).

#### **5.2 The end-user energy market**

An analysis of the aggregate energy trends within the domestic, commercial/tourism/industrial and horticulture/vinery sectors are now provided. Which is all very detailed (but necessary) in leading us to quantify and appreciate the general trend within the end-user energy market.



**Domestic sector energy consumption**

Electricity (41%), Kerosene (25%) and Coal (21%) account for 87% of the domestic energy market (Gas consumption represents most of the remainder), Figure 36.

Using the tariff costs in the domestic energy market (see TABLE 4.9; with Gas Oil retailed at 5% below the price of Kerosene) produces an estimated cost of supplying the domestic energy sector of £18,725,400 (Electricity - £9,651,100, Oil - £2,494,200, Coal £2,632,500 and Gas - £3,947,600) at 1992 prices.

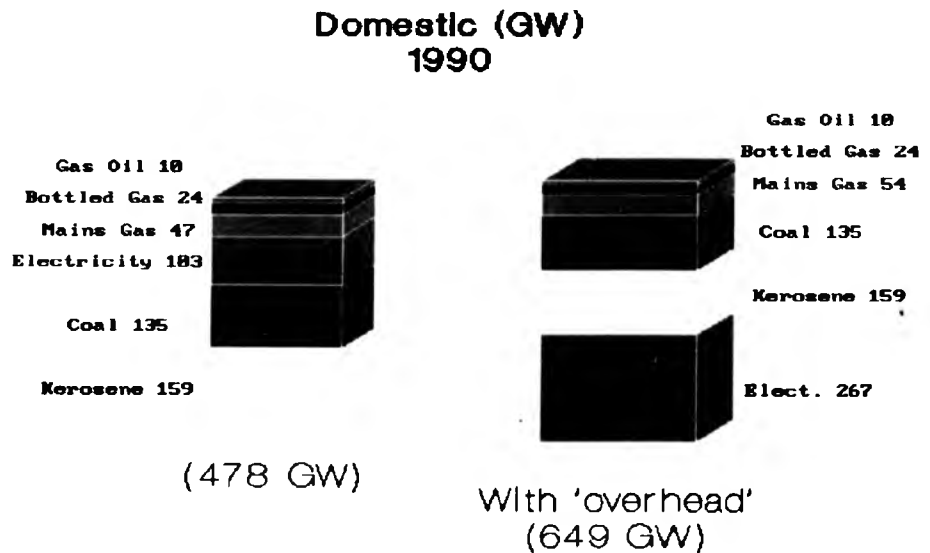

Figure 36

Figure 37 details the trend in domestic electricity demand over the period 1963-90.

### Domestic electricity demand by final user (1963-90)

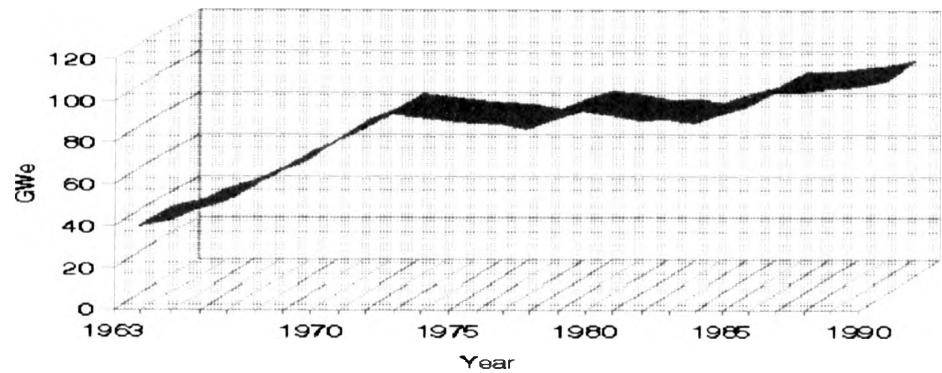

Figure 37

The two most important factors influencing electricity sales are economic growth and population. Figure 38 details the correlation against GNP; Figure 39, against population.

### Domestic electricity consumption/GNP<sup>1</sup>

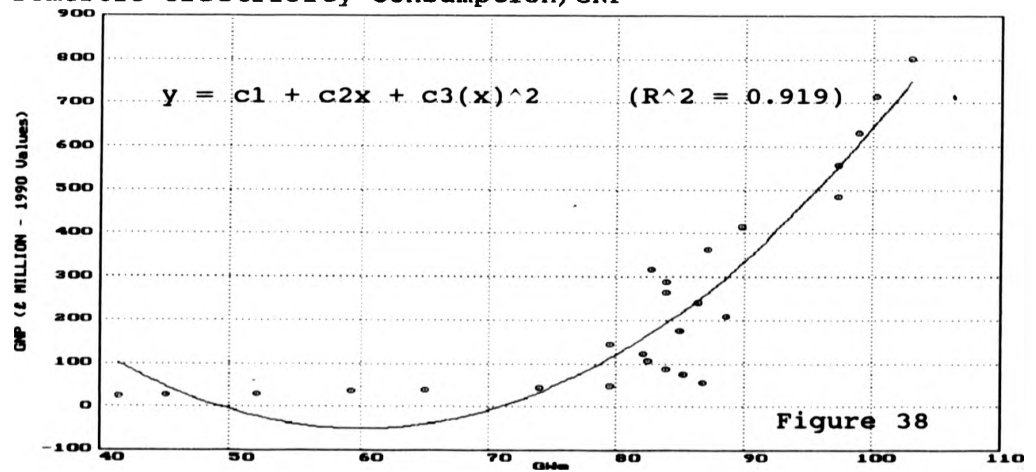

Figure 38

1. Domestic electricity consumption/GNP, R<sup>2</sup> is much better over the last ten years, 0.99.

Domestic electricity consumption/population<sup>1</sup>

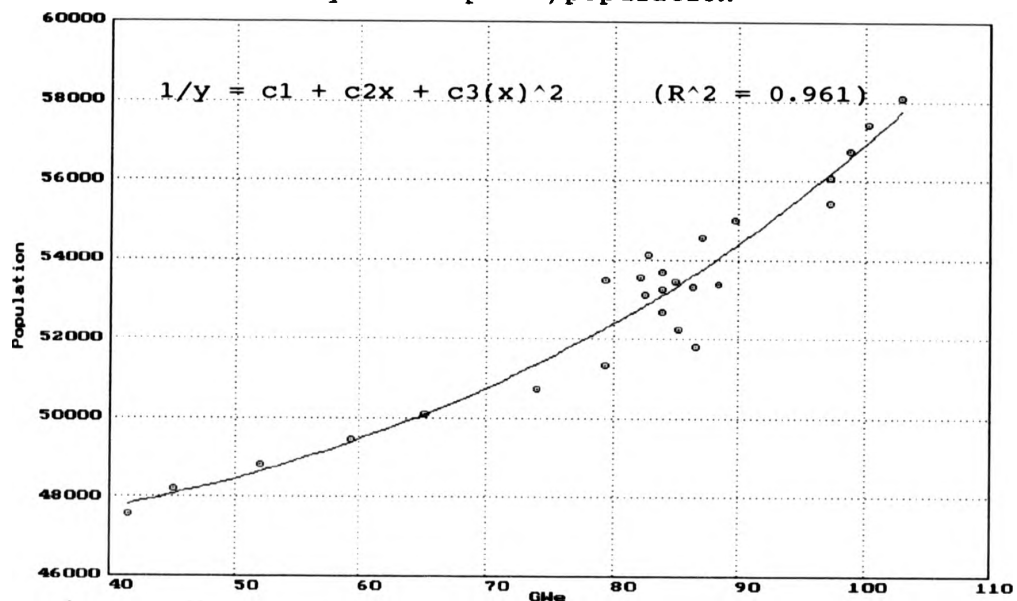

Figure 39

Kerosene is the second largest demand within the domestic energy sector and is primarily used for domestic oil fired central heating purposes. Over the period 1984-90 there was an increase in demand of 250%<sup>2</sup>, which represents an increase in Kerosene imports into the Island of over 100 GW in 1990 compared with 1984<sup>3</sup> for example.

1. Domestic electricity consumption/population,  $R^2$  is no better over the last ten years.
2. The increase in domestic electricity demand over the same period was 18%.
3. Again, the two most important factors influencing Kerosene consumption are economic growth ( $R^2 = 0.920$ ) and population ( $R^2 = 0.923$ ), taken over the period 1977-90.

Kerosene against crude oil price (from BP World Energy - 1990) produces a low  $R^2 = 0.357$ , which may indicate oligopolistic behaviour among the four petroleum agencies on the Island, with regard to their mark-up (see Section 4.2).

Increased demand for Coal occurred between the period 1981-86 when real electricity prices were high<sup>1</sup>.

Between 1984-90 annual Gas consumption increased by 44%, mainly again due to the increased use of domestic central heating.

**Commercial/tourism/industrial sector energy consumption**

Electricity (65%), Gas Oil (17%) and Gas (11%) account for 93% of the commercial/tourism/industrial energy market, Product 469 represents most of the remainder, Figure 40.

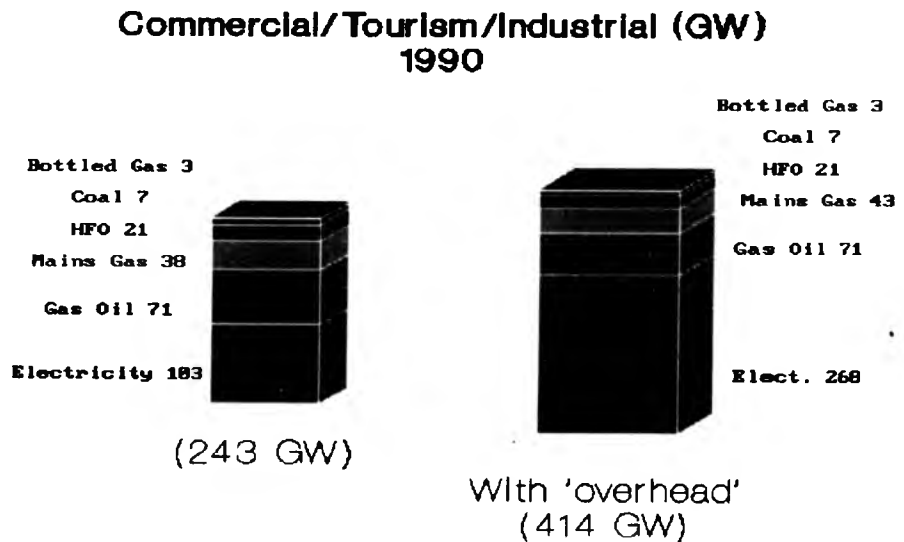

Figure 40

Using the tariff costs in the domestic energy market

1. There is no correlation between Coal consumption and GNP or population, and low correlation against average electricity price ( $R^2 = 0.561$ ).

again as a guide only (see TABLE 4.9; with Gas Oil retailed at 5% and HFO/Product 469 at 40% below the price of Kerosene) produces an estimated cost of supplying the commercial/tourism/industrial energy sectors of £13,255,200 (Electricity - £9,651,100, Oil - £1,188,000, Gas - £2,279,600 and Coal - £136,500) at 1992 prices.

Figure 41 details the trend in commercial/tourism/industrial electricity demand over the period 1963-90.

### Comm/Tour/Ind electricity demand by final user (1963-90)

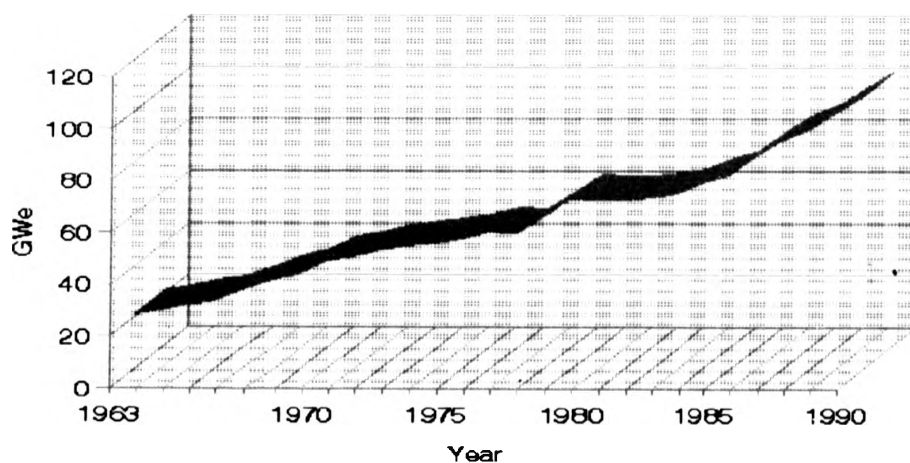

Figure 41

Unlike the domestic sector, electricity consumption within these sectors are influenced by electricity price, as well as economic growth and population; see the correlations in Figures 42, 43 and 44 respectively.

Comm/Tour/Ind electricity consumption/ave.price per unit<sup>1</sup>

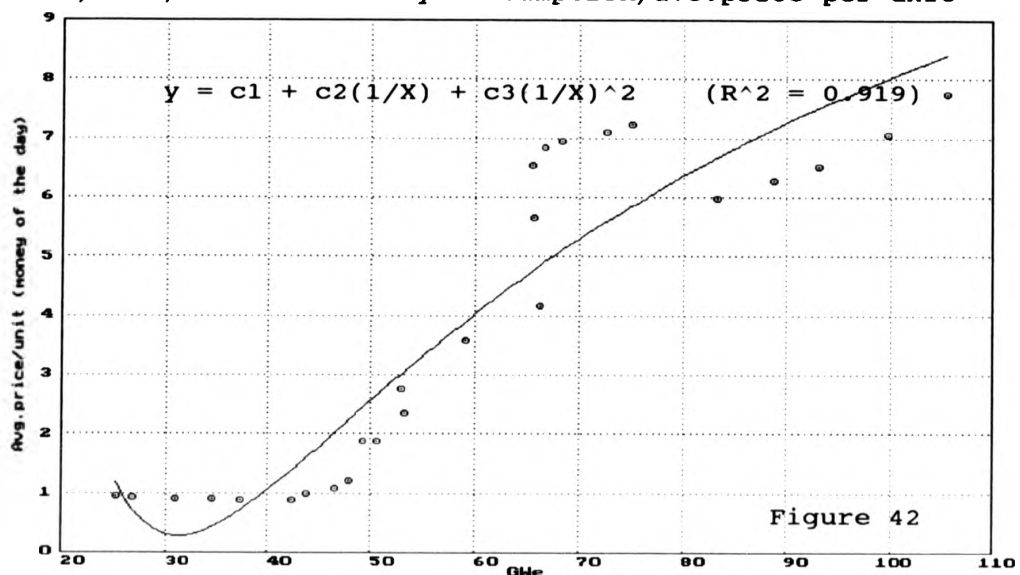

Figure 42

Comm/Tour/Ind electricity consumption/GNP<sup>2</sup>

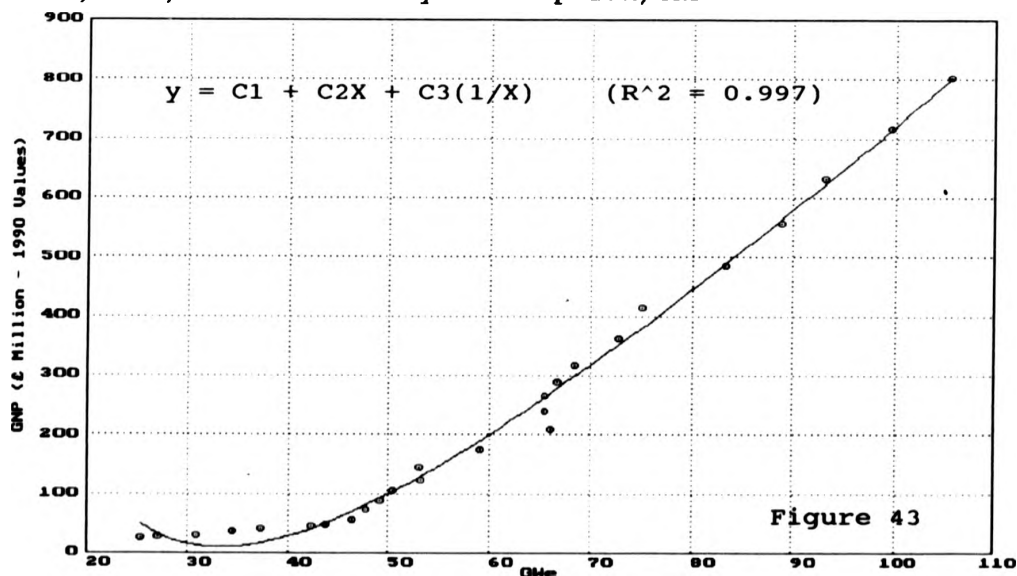
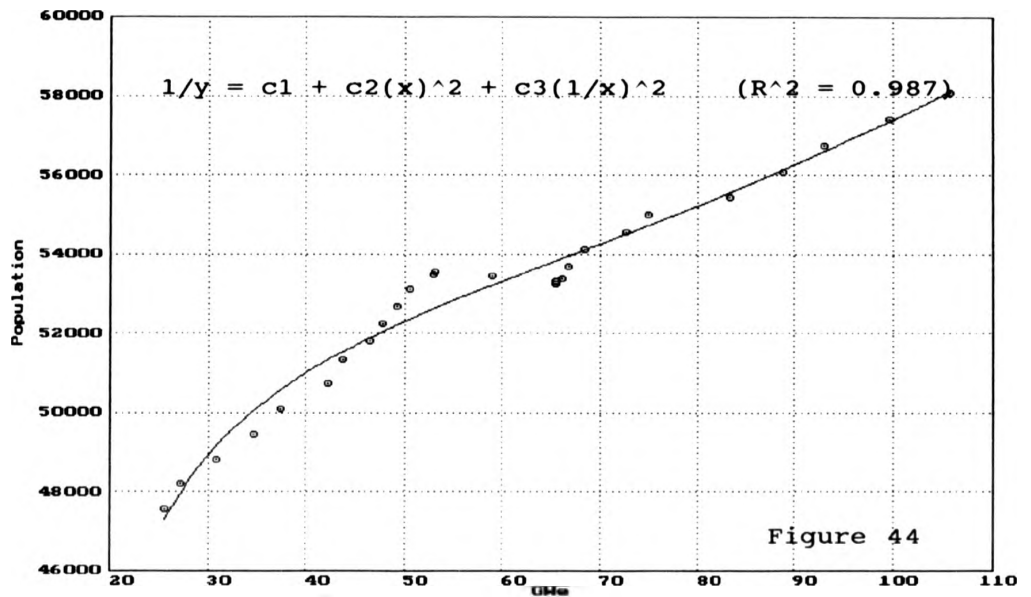

Figure 43

1. Between 1979 and 1982 the increased cost of fuel was a factor in reducing electricity consumption and encouraging energy conservation.
2. Since 1975 the relationship has been linear; for every £13.33 million of GNP an extra 1 GWe is required.

Comm/Tour/Ind electricity consumption/population<sup>1</sup>



Over the period 1984-90 electricity consumption in these sectors has increased by 45%, double the 18% growth experienced in the domestic sector over the same period.

Gas Oil is the second largest energy demand within these sectors, used mainly for space heating.

The Gas market is just over half that of the domestic sector; with Gas cooking (within the tourism sector) an important end-use<sup>2</sup>.

1. Between 1984 and 1990 a linear relationship exists.
2. Gas consumption has a high correlation with crude oil price (BP World Energy - 1990)  $R^2 = 0.910$ . Indicating that Gas pricing on the Island has a close relationship with the price of its feedstock.

### Horticulture/vinery sector energy consumption

HFO/Product 469 (65%), Coal (15%) and Electricity (9%) account for 89% of the horticulture/vinery energy market; of the remaining demand, Kerosene is widely used by growers for CO<sub>2</sub> enrichment within greenhouses, Figure 45.

Using the tariff costs in the domestic energy market again as a guide only (see TABLE 4.9; with Gas Oil retailed at 5% and HFO/Product 469 at 40% below the price of Kerosene) produces an estimated cost of supplying the horticulture/vinery energy sector of £4,249,200 (Oil - £2,285,400, Coal - £877,500, Electricity - £1,030,700 and Gas - £55,600) at 1992 prices.

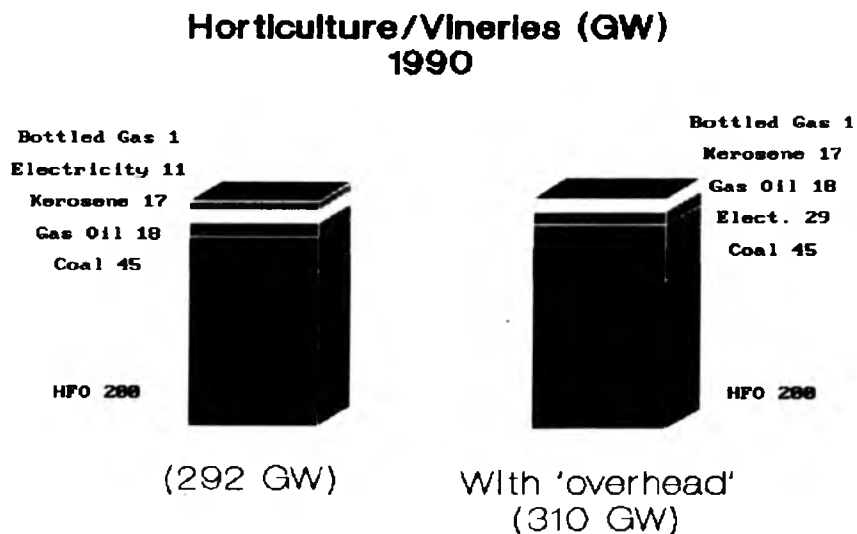

Figure 45



Figure 46 details the trend in end-user HFO and Product 469 demand over the period 1977-90.

### HFO demand (1977-90) (including Product 469)

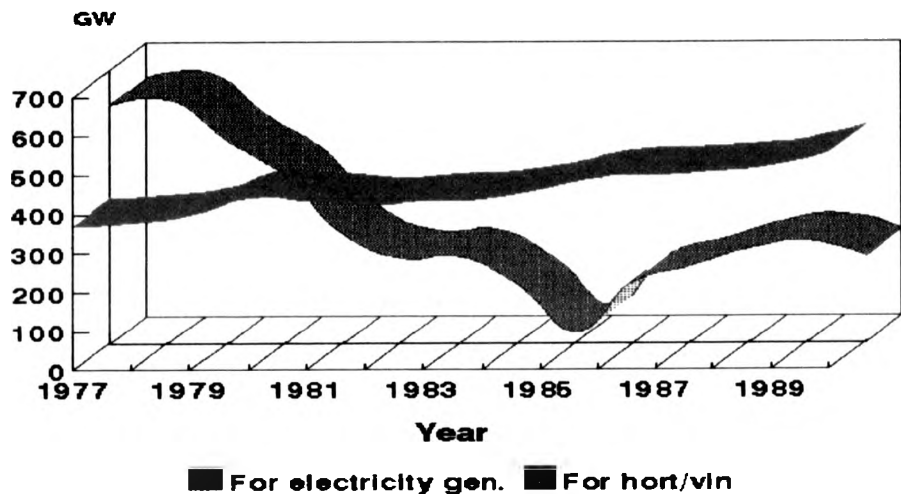

Figure 46

Over the period 1985-90 HFO demand in this sector increased by over 650%, which represents an increase in imports of 194 GW in 1990 compared with 1985 for example.

Important is that there is a close correlation between the average price of electricity and HFO ( $R^2 = 0.934$ ), which reflects the price setting role of the SEB with regard to HFO sales to growers, as well as setting electricity prices.

Coal represents only ten large growers (mainly roses), with electricity really only used for pumping and lighting (providing daylight conditions at night to promote early

growth for example<sup>1</sup>).

### 5.3 The general trend

In order to appreciate the general fuel trends in the final user energy market we focus on the years 1964, 1976 and 1990, Figure 47<sup>2</sup>.

The total conversion/transmission/distribution losses in those years was, as follows:-

In 1964 - 121 GW.

In 1976 - 194 GW.

In 1990 - 360 GW.

Some threefold increase in energy losses over the period and rising, which represents an appalling wastage of fuel energy and suggests:-

(1) Electricity intensive activities.

(2) Increased use of space heating (notable is the significant increase in Kerosene and Gas for domestic central heating purposes).

(3) The SEB's significant price setting role in all economic sectors<sup>3</sup>.

1. Recently the SEB have particularly targeted growers, writing to each of the major growers to encourage greater use of their Economy 7 tariff.
2. Important is that the trend with respect to oil is inclusive of the transport component of Gas Oil (diesel).
3. Electricity has the largest market share in domestic and commercial/tourism/industrial sectors. In the horticulture/vinery sector also, the SEB is involved in supplying HFO to growers.

growth for example<sup>1</sup>).

### 5.3 The general trend

In order to appreciate the general fuel trends in the final user energy market we focus on the years 1964, 1976 and 1990, Figure 47<sup>2</sup>.

The total conversion/transmission/distribution losses in those years was, as follows:-

In 1964 - 121 GW.

In 1976 - 194 GW.

In 1990 - 360 GW.

Some threefold increase in energy losses over the period and rising, which represents an appalling wastage of fuel energy and suggests:-

- (1) Electricity intensive activities.
- (2) Increased use of space heating (notable is the significant increase in Kerosene and Gas for domestic . central heating purposes).
- (3) The SEB's significant price setting role in all economic sectors<sup>3</sup>.

1. Recently the SEB have particularly targeted growers, writing to each of the major growers to encourage greater use of their Economy 7 tariff.
2. Important is that the trend with respect to oil is inclusive of the transport component of Gas Oil (diesel).
3. Electricity has the largest market share in domestic and commercial/tourism/industrial sectors. In the horticulture/vinery sector also, the SEB is involved in supplying HFO to growers.

Figure 47

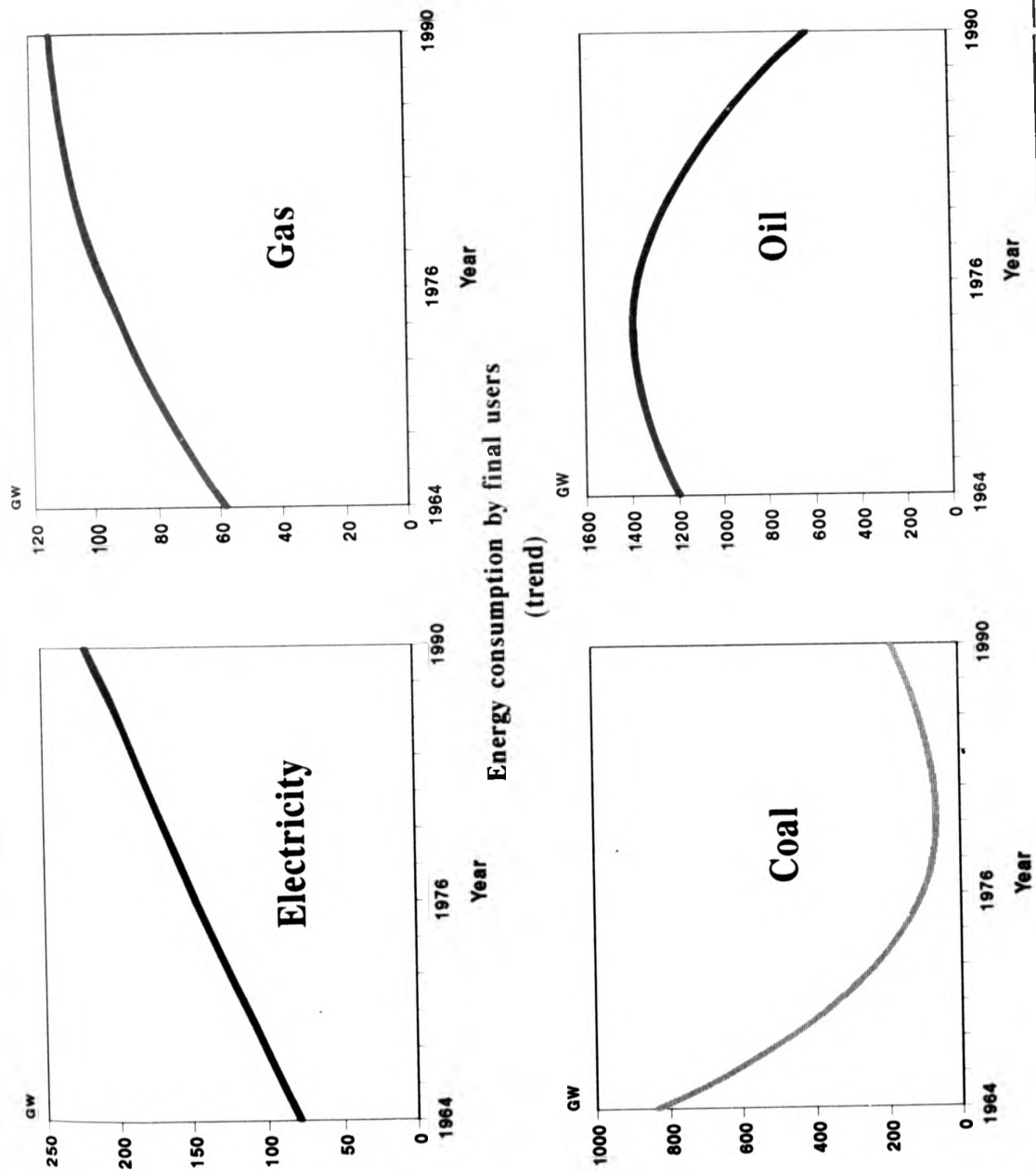

### Transport sector energy consumption

The trend here is what Leach<sup>1</sup> refers to as "the time bomb of personal transport energy consumption".

Motor Spirit (67%) and Gas Oil (marine [11%] and road [10%]) account for 88% of the transport energy market; aircraft movements represent the remaining demand, Figure 48.

Using the typical tariff costs in the transport energy market (see TABLE 4.10), the estimated cost of supplying the transport energy sector is estimated to be £14,461,200 (Motor spirit - £11,053,200, Gas Oil - £1,687,200, Avtur - £1,452,600, Avgas - £268,200) at 1992 prices.

### Transport (GW) 1990

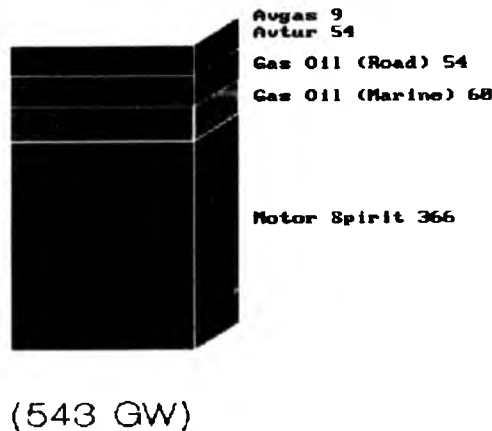

Figure 48

1. Leach, G, 1986, 'Energy and growth: A comparison of 13 industrial and developing countries'.

Figure 49 details the trend in end-user Motor Spirit demand over the period 1965-90.

### End-use motor spirit demand (1965-90)

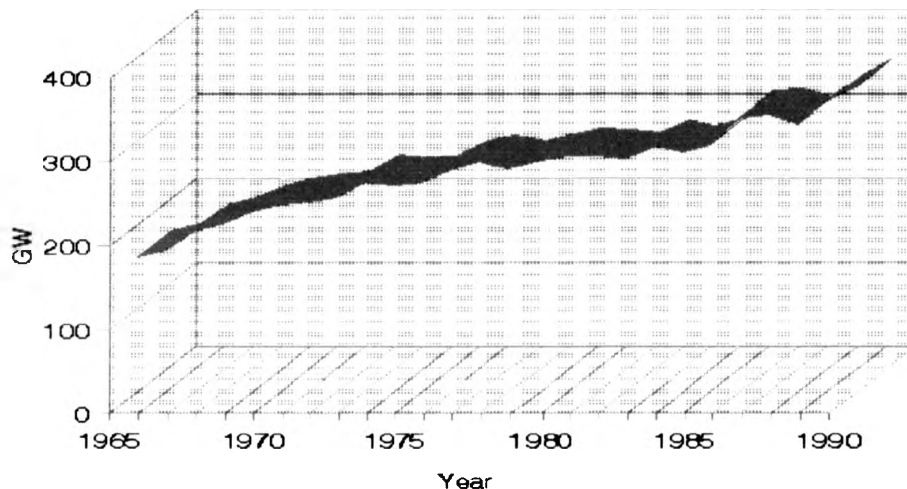

Figure 49

With higher disposable income, passenger travel in Guernsey has changed from public transport to the more energy-intensive motor car. Figure 50 indicates the close correlation between Motor Spirit consumption and GNP.

The second largest energy demand within the transport sector is for Gas Oil. 70% of the marine demand is for the Condor hydrofoil services between the U.K. mainland/ Jersey/Guernsey/France, the remaining 30% for marine, pleasure purposes.

The Gas Oil (diesel) for road transport is used by company trucks, vans, buses, tractors, forklifts etc.

Motor spirit consumption/GNP

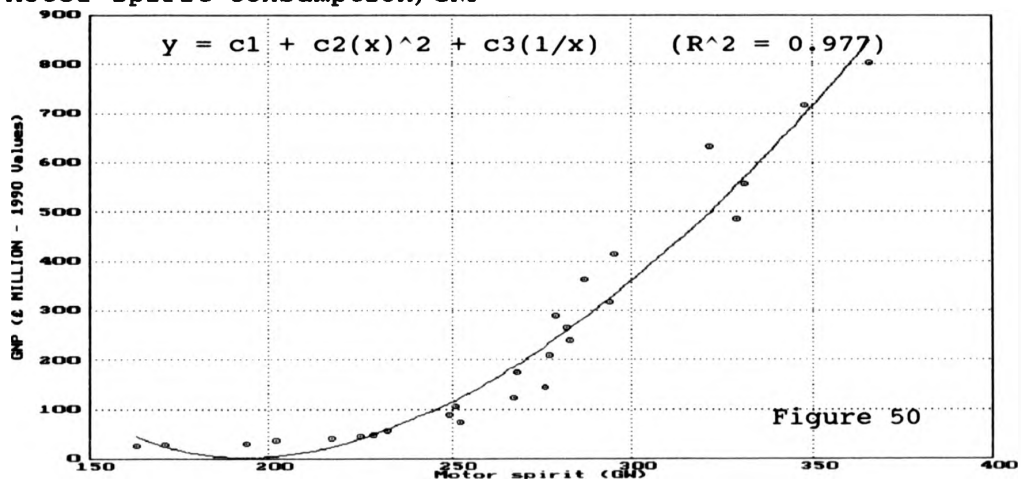

5.4 Energy conversion

Electricity production

Since its formation 60 years ago the SEB have made extensive use of diesel engines for power generation; the present installed capacity is shown in TABLE 5.1.

TABLE 5.1 - Generating units currently installed at the central power station site (Vale)

Unit	Manuf/Model	Capacity (MWe)
B1	Mirrlees/KV12	3.8
B2	Mirrlees/KV12	3.8
B3	Mirrlees/KV12	3.8
B4	Mirrlees/KV12	3.8
B5	Mirrlees/KV12	3.8
B6	Mirrlees/KV12	3.5
C1	Sulzer/9RNF68M	12.6
C2	Sulzer/9RNF68M	12.6
C3	Sulzer/9RNF68M	12.6
C4	Sulzer/9RTA58	14.2
D1	Sulzer/9RTA58	14.2 (New)
Gas T	Stal Laval/GT35	13.5
		-----
		102.0

All the electricity requirements of the Island are met by medium-speed diesels in the Vale 'B' and large slow-speed diesels in the Vale 'C' and 'D' central power station.

Overall efficiency of the 'B' station engines from 1977-80 was 35.6%, but since the introduction of the large Sulzer 9RNF68M slow-speed engines (over the period 1981 to 1987 [C1-C3]) the overall efficiency increased to 39.5% (+3.9%). Since the introduction of the 9RTA58 (over the period 1987-90 [C4]) the overall centralised power station efficiency increased to 41.3% (+1.8%), Figure 51.

This further increase of 1.8% in conversion efficiency is achieved by improved turbocharger design and ignition/scavenge air system improvements.

### SEB - Fuel energy conversion (net efficiency (%))

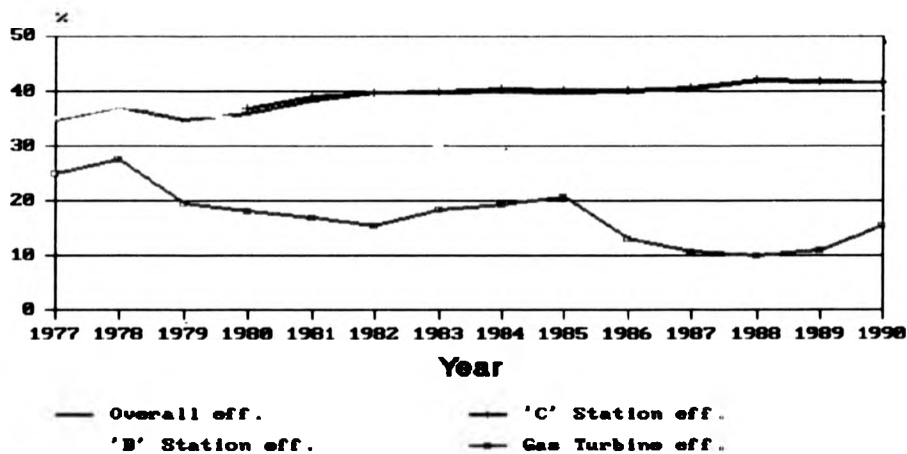

Figure 51



Because of their higher fuel efficiency the large slow-speed engines are used as 'base load' sets and provide the bulk of SEB centralised generation. The Mirrlees KV12 Major medium-speed engines are used only when the Sulzer engines are out of service for maintenance or repair.

#### **Mains gas production**

The mains gas production plant located in St. Peter Port (which produces LPG/air at 716 Btu/cu.ft) was supplied by Old Park Progas Limited in 1976. It comprises two variable venturi mixers (one working and one standby) together with a range of fixed venturis, with a maximum capacity of 280,000 cu.ft/hr. These mixers make into a small 250 cu.ft gas holder fitted with a bubble tube control which operate the mixers in a 'cascade' cycle, maintaining production in balance with demand.

No storage capacity is required, but since major plant failures are possible one 0.5 million cu.ft holder is maintained in commission and kept full for emergency use. Vaporisation of the LPG is provided by LPG fired boilers, the thermal efficiency of which is in excess of 98%. The plant operates on an unattended basis, with an automatic shut down system.

#### **5.5 Who are the energy users ?**

The division between energy use for consumption and energy use for production purposes is a distinctive feature on Guernsey. Consumption is the largest category, which consists mainly of the domestic sector and private passenger

transport:-

End-users	(Year 1990)	
	GW	
Domestic	-	649
Private passenger transport	-	366
		-----
		1015

**Domestic end-users:**

The most distinctive characteristic of household energy consumption is its variability. Apart from income and prices several other factors such as climate, fuel availability, culture and tradition affect not only the amount of energy that is consumed but (as we have shown) the fuel structure. In 1990 there were 21,206 domestic (residential) energy end-users on the Island<sup>1</sup>.

**Private passenger transport:**

The number of vehicles in use on the Island over the period 1950-90 is shown in Figure 52.

On a very small island like Guernsey even a modest increase in traffic cannot really be accommodated without considerable environmental damage; coupled with a further increase in energy consumption and pollution.

1. Derived from the SEB billing database.

### Total number of motor vehicles in use (1950-90)

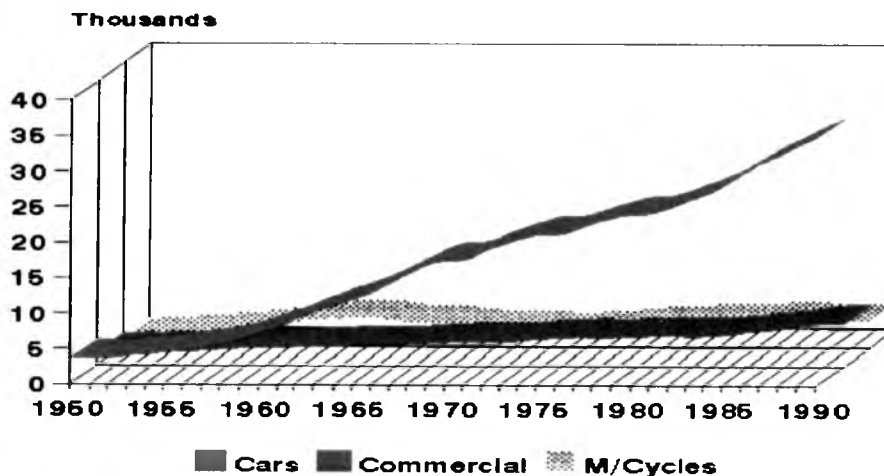

Figure 52

The production category consists of the commercial/tourism/industrial, horticulture/vinery and freight transport:-

End-users	(Year 1990) GW
Commercial/tourism/indust.	- 414
Horticulture/vineries	- 310
Freight transport	- 54
	-----
	778

This accounts for the bulk of energy use; marine (60 GW) and air transport (63 GW) are not included.

#### Commercial/tourism/industrial end-users:

These sectors have a variety of activities, the public sector in particular accounts for around 18% of total employment on the Island. Which represents a significant

component of commercial energy sector consumption in the form of public buildings (340 sites). The financial services share of GNP represents very high value with relatively low energy content. A study of retail outlets<sup>1</sup> suggests that the Island is not underprovided with shops etc.

Traditionally important has been the tourism sector which has seen a steep fall in visitors<sup>2</sup> (over 80% of the tourism business comes from the U.K.).

It is difficult for Guernsey to become a significant light industrial location because of the beneficial position of other light industrial areas near to large markets, and also the high costs of transport to and from the Island.

#### **Horticulture/vinery end-users:**

In 1986 there were some 2,000 greenhouse holdings on the Island, comprising a total area of 877 acres<sup>3</sup>. Nearly all the holdings under 800ft were run by part-time or seasonal workers, over 800ft by full-time professional growers.

1. See Chas E Goad Limited, 1990, 'Sanistat - Profile report - Shop counts', retail specialist.

2. Costs have been kept down by the use of foreign labour (usually from the island of Madeira).

3. See States Committee for Horticulture, 1988, 'A strategic overview of Guernsey horticulture - consultation document'.

## SUMMARY

(1) Accounting for energy flows in 1990:-

Fuel		Transport	
	GW		GW
Heavy Fuel Oil	559	Gas Oil	114
	221	Motor Spirit	366
Gas Oil	10	Avtur	54
	86	Avgas	9
	6		
Kerosene	176		
LPG	125	Static plant	3
Coal	52		---
	135		546
	----		---
	1370		
	----		

(2) There is little virtue in a non-linear model as a 'predictive tool' when 10-15 years of very linear behaviour is evident.

(3) There is evidence of monopolistic/oligopolistic behaviour in the (historic) energy market.

(4) There is a threefold increase in energy losses (from 1964 to 1990) and they are increasing.

(5) Using present energy losses as a substitute for oil and coal imports (through distributed cogeneration) may potentially offer a significant reduction in prime fuel imports into the Island, but this has to be carefully tested.

(6) The total 1992 expenditure of the States of Guernsey (covering health services, social services and education) was £156.9 million. A significant management effort is used

to control these costs (The Civil Service)<sup>1</sup>.

The estimates in the present work suggest that the total energy market on the Island may be worth in the order of £50 million at 1992 prices. This is almost a third of all States of Guernsey expenditure in 1992 and represents a significant cost to the Island, which is not controlled at the Island level (unlike health services, social services and education).

(7) Present Island institutions (and non-intervention in the energy sector) have been unable to reduce or eliminate high energy losses (even when small islands generally are looking for ways to conserve energy).

1. The money to pay for all these services is raised by income tax on companies, individuals etc (no borrowings).

## CHAPTER 6

### 'DYNAMIC' CONTEXT OF THE SYSTEM MODEL

After having examined aggregate energy consumption on the Island we now focus on end use activities in this Chapter. Energy use needs to be better understood from the demand viewpoint but this raises the question of how detailed such an understanding needs to be, and how detailed it can be in view of the limitations of data.

There are severe limitations to the attainable depth of disaggregation; at the limit of very high disaggregation everything is described and nothing understood. This Chapter leads to the formation of an elementary 'energy profile' database for the largest electricity end-users, in each economic sector, in each parish.

#### 6.1 Parish energy demands

Early in the research it became apparent that Island energy statistics were inadequate for the level of disaggregation required. To overcome this problem and to develop a detailed picture of present energy consumption (disaggregated by end-user for each energy consuming sector [domestic, commercial/tourism/industrial and vineries]). A database which registers ALL energy consumers on the Island (electricity billing) was examined.

The SEB consumer database is held on an ICL mainframe computer and is of high quality (eg. completeness, accuracy, reliability). The existing software was modified by the

Writer to apply Pareto analysis to each sector of the database to determine, on a per parish basis, electricity consumption using an energy banding approach<sup>1</sup>.

The database was then asked to output average electricity consumption for each parish over the four quarters of 1990, in four range bands. The four bands cover annual consumption of 1) up to 400 kWhe 2) 401-8000 kWhe 3) 8001-80000 kWhe and 4) in excess of 80000 kWhe.

This was applied to each of the domestic, commercial, tourism, industrial and vinery sectors within the database.

The principle of the approach is that large heat energy end-users also usually have a high electricity requirement. It does not, however, follow that all large electricity end-users also have a high heat energy demand. A similar technique was used on a city centre study of the U.K. mainland city of Leicester<sup>2</sup>, where the approach worked well, with few unexpected exceptions.

A benefit of this approach is that a detailed electricity consumption/demand picture can be assembled for each parish which will be useful later. It focuses attention on the important larger consumers, some of whom are significant in terms of parish based energy planning.

1. Published electricity consumption statistics have to-date always been produced on an Island-wide aggregate (sectoral) basis and not per parish.

2. See Scragg, D, 1987, 'Means of identifying heat loads within a city'.



Figures 53-61 provide the results of this banding analysis, the significance of the larger end-users (ie. those in Band 4) are clearly indicated<sup>1</sup>. They dominate energy demand at their location on the Island.

TABLE 6.1 details the number of Band 4 end-users in the production category and their contribution to production electrical energy demand within each of the parishes.

**TABLE 6.1 - Band 4 end-users and their contribution to production electrical energy demand**

Parish	Number of Band 4 end-users	% of total energy for production
Vale	26	53
St.Sampsons	33	57
Castel	25	60
St.Saviours	7	56
St.P/Torteval	7	40
Forest	8	74
St.Andrews	7	77
St.Martins	32	71
St.Peter Port	130	56

In order to make the research effort manageable there was a need to apply Pareto analysis again to the Band 4 end-users to determine who the largest end-users are in each of the productive economic sectors, TABLE 6.2. This is in accord with the principle of 'cyclical' refinement, which is a frequent requirement in managerial planning processes.

1. There are no Band 4 end-users in the domestic sector.

# The Parish of Vale

## Electricity demand by end-users

Total = 25.9 GW (1990)

Vineries (1.4 GW)

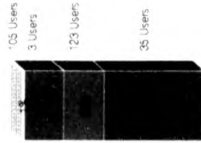

Domestic (15.6 GW)

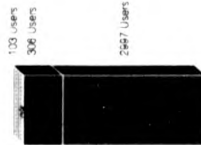

Tourism (1.6 GW)

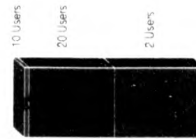

Commercial (5.3 GW)

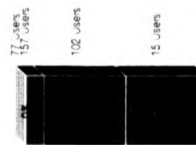

Industrial (2 GW)



Band 1 = Yellow  
Band 2 = Blue  
Band 3 = Green  
Band 4 = Red

Figure 53

# The Parish of St. Sampsons

## Electricity demand by end-users

Total = 26.5 GW (1990)

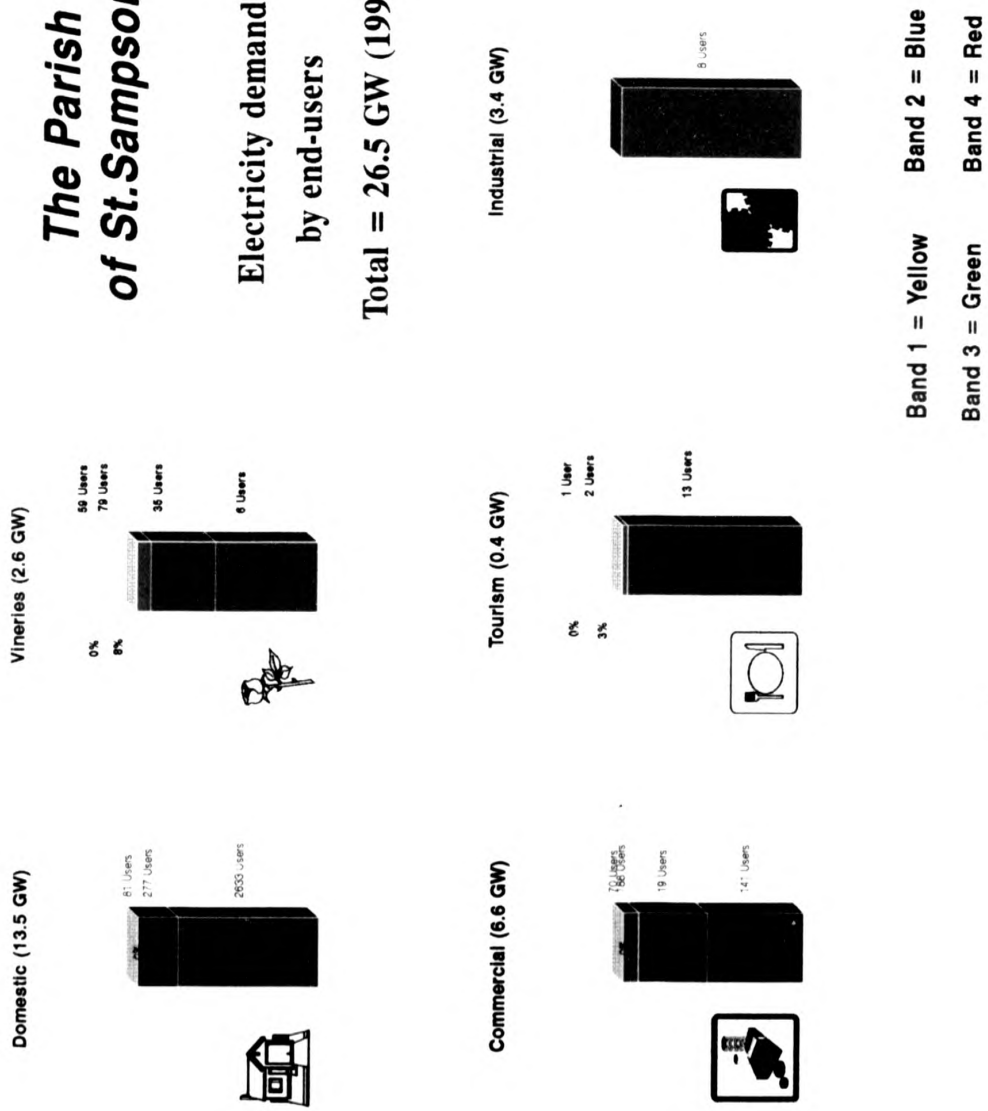

Figure 54

# The Parish of Castel

## Electricity demand by end-users

Total = 22.2 GW (1990)

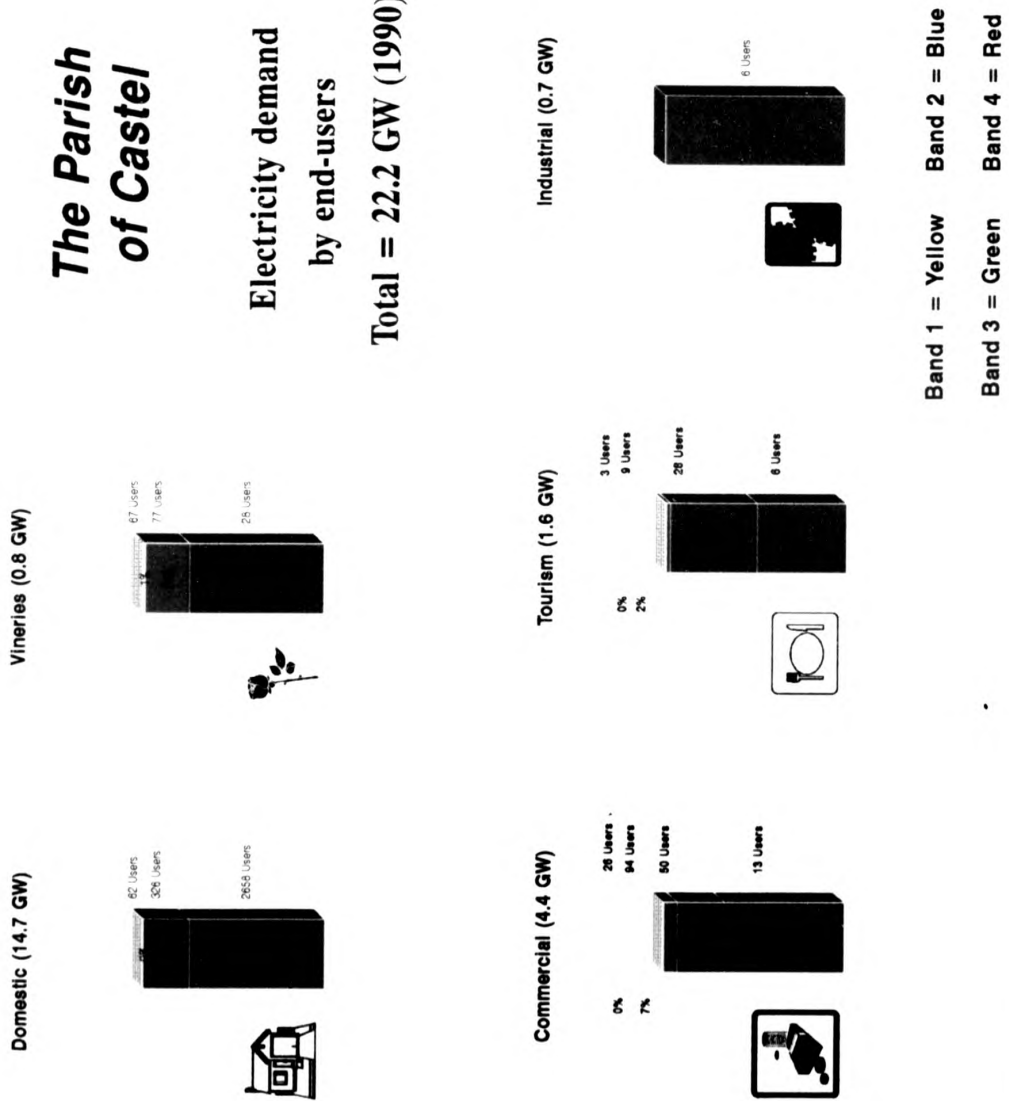

Figure 55

# The Parish of St. Saviours

Electricity demand by end-users

Total = 7.8 GW (1990)

Vinerias (0.6 GW)



Domestic (4.6 GW)



Industrial (1.1 GW)



Tourism (0.4 GW)

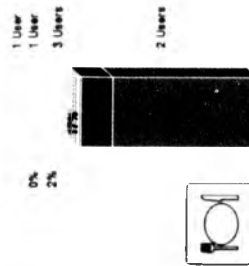

Commercial (1.1 GW)



Band 1 = Yellow      Band 2 = Blue

Band 3 = Green      Band 4 = Red

Figure 56

# The Parishes of St. Peters/Torteval

Electricity demand  
by end-users

Total = 8.9 GW (1990)

Vinerias (1.1 GW)

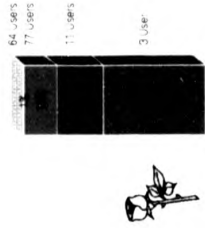

Domestic (5.9 GW)



Tourism (0.7 GW)

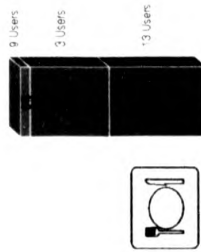

Commercial (1.2 GW)

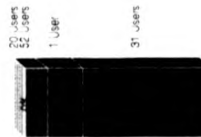

Band 1 = Yellow Band 2 = Blue

Band 3 = Green Band 4 = Red

Figure 57

# The Parish of Forest

## Electricity demand by end-users

Total = 7.2 GW (1990)

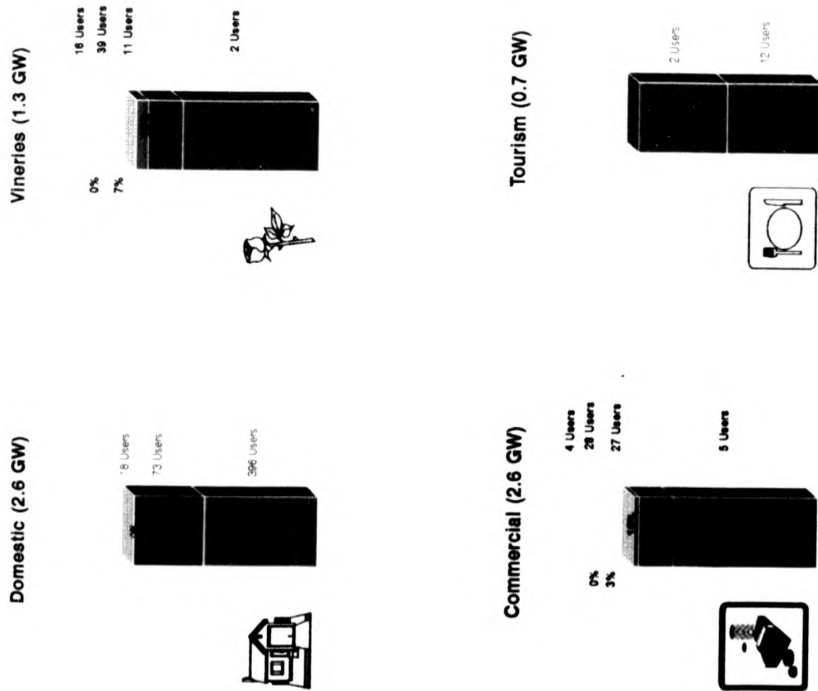

Band 1 = Yellow    Band 2 = Blue  
 Band 3 = Green    Band 4 = Red

Figure 58

# The Parish of St. Andrews

## Electricity demand by end-users

Total = 9 GW (1990)

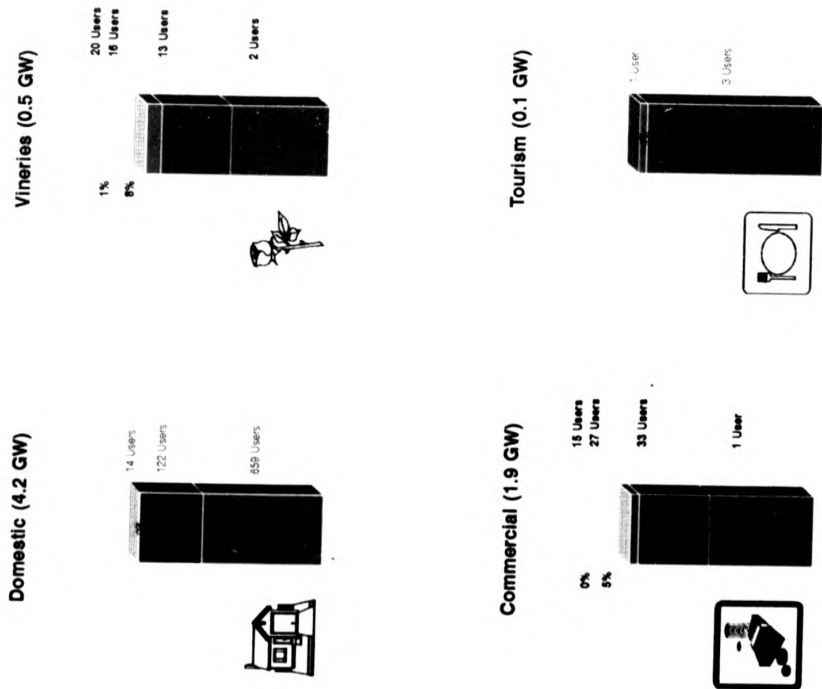

Band 1 = Yellow    Band 2 = Blue  
 Band 3 = Green    Band 4 = Red

Figure 59



# The Parish of St. Martins

Electricity demand  
by end-users  
Total = 21 GW (1990)

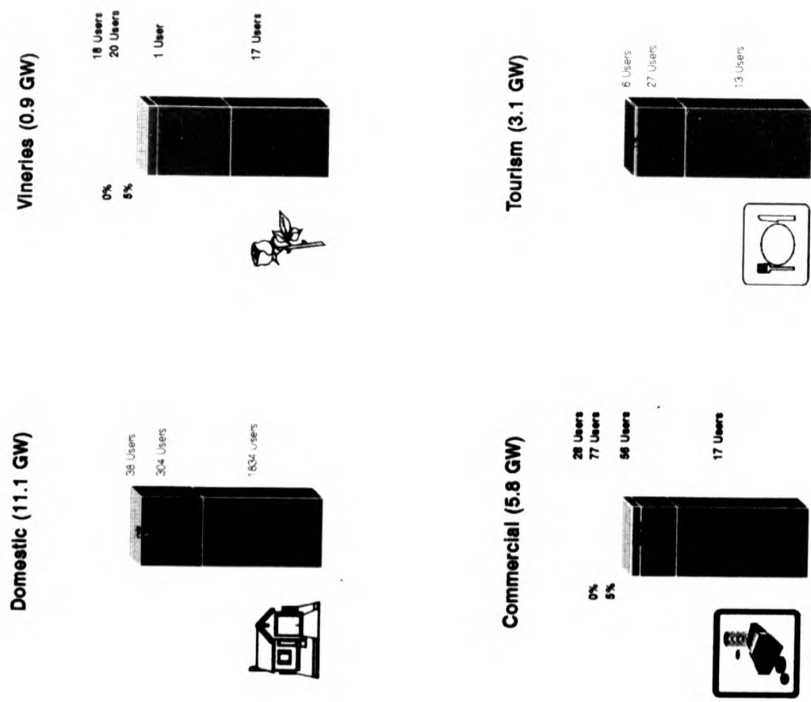

Band 1 = Yellow    Band 2 = Blue  
Band 3 = Green    Band 4 = Red

Figure 60

# The Parish of St. Peter Port

Electricity demand  
by end-users  
Total = 82.8 GW (1990)

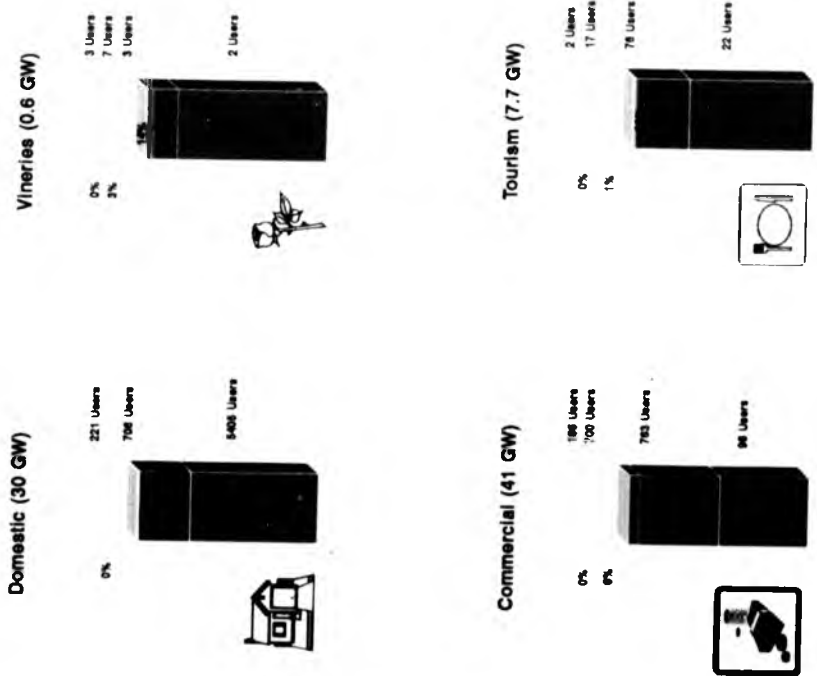

Band 1 = Yellow    Band 2 = Blue  
Band 3 = Green    Band 4 = Red

Figure 61

These large end-users are significant in terms of parish based energy planning, and there is a great need to know far more about their QQT consumption patterns (electricity and also heat energy). Necessarily, this means visiting each site and measuring/collecting end-user energy data but this is not easy.

**TABLE 6.2 - The largest end-users in each economic sector, within each parish**

<b>Vale</b>		<b>St.Sampsons</b>	
Alliance Cash and Carry	(C)	States Prison	(C)
Vingtaine Vinery	(V)	Kenilworth Vinery	(V)
Peninsula Hotel	(T)	-	(T)
Juas Quarry	(I)	Les Vardes Quarry	(I)
<b>Castel</b>		<b>St.Saviour</b>	
King Edward VII Hosp	(C)	Mont Variouf School	(C)
-	(V)	Les Mourants Vinery	(V)
Hougue du Pommier Hotel	(T)	Atlantique Hotel	(T)
States Water	(I)	States Water	(I)
<b>St.Peter/Torteval</b>		<b>Forest</b>	
Le Riche Stores	(C)	States Airport	(C)
Bader Roses	(V)	Sovereign Flowers	(V)
Imperial Hotel	(T)	Mallard Country Hotel	(T)
-	(I)	-	(I)
<b>St.Andrews</b>		<b>St.Martin</b>	
Grammar School	(C)	Princess Eliz. Hosp.	(C)
J.Angenent Roses	(V)	Bali-Hai Vinery	(V)
-	(T)	St.Margarets Lodge	(T)
States Dairy	(I)	-	(I)
<b>St.Peter Port</b>			
Beau Sejour	(C)	C - Comm. & public bldgs.	
Ramee Roses	(V)	T - Tourism	
St.Pierre Park Hotel	(T)	I - Industrial	
Intersurgical Ltd	(I)	V - Vineries	

### 6.2 Clusters of QQT demands

This is the 'dynamic' context of the 'Energy Market Analysis' sub-system model, where considerations such as the

variation in energy consumption (as well as the absolute level) are important.

We will show that the energy needs of such 'clusters' of demand may be better matched, by taking their local needs, at different times of day and season, and matching these to locally generated sources. However, this depends upon a rigorous audit of energy consumption patterns, both in terms of quality (Q), quantity (Q) and demand time-cycles (T). With the possible benefit to the Island of a far more optimal use of input fuels (and may result in relatively lower cost).

The usual SEB customer segmentation for example is far too general to be useful for this purpose. It ignores the differences in usage (QQT) patterns and neglects to take proper account of location specific (parish) cost-of-service differences (see Chapter 11).

End-user energy requirements vary in terms of thermodynamic availability (Quality), size (Quantity), time of use of service/period of use (Timing) and also important, location.

'QQT' analysis lies at the heart of our strategic planning work on Guernsey. The fluctuating demand patterns for electricity and heat (focussing on the Guernsey parishes) provides a suitable platform for investigating the nature of these QQT demand clusters. The results of this then feeding into scenarios for parish demands (see Chapter 7) and enabling us to evaluate possible energy supply

sources within the 'Energy Planning' sub-system model (operated on paper in Chapters 8, 9, 10 and 11).

#### QUALITY

Quality of energy is related to the availability of energy to produce useful work. High-quality energy (such as electricity) has high availability, and during any real process, the availability (or quality) is reduced (the energy is degraded), in accordance with the requirement of the Second Law of Thermodynamics<sup>1</sup>. Once a fuel has been used a significant proportion of its energy content is lost forever. It is therefore surely sensible to make prudent use of existing fuels a priority (particularly so on very small islands).

It is neither technically necessary nor in any sense essential to heat rooms and buildings at 20-25 C by burning fossil fuels at 1200 C. Although modern boilers achieve conversion efficiencies of 80% +, the maximum energy of primary fuel sources remain substantially unutilised. In cogeneration plant (with network distribution of hot water), a much wider temperature gradient can be exploited from

1. Despite the First Law of Thermodynamics that energy cannot be destroyed, the Second Law implies that although the energy may still be there, once used it will in some way be 'downgraded'.

See Benson, R.S, 1976, 'Advanced engineering thermodynamics' or

Rogers, G.P.C, 1967, 'Engineering thermodynamics, work and heat transfer' or

Sherwin, K, 1993, 'Introduction to thermodynamics'.

generating electricity (the associated bulk low temperature heat can then be distributed by thermally insulated pipework).

This limited, so called 'Exergy'<sup>1</sup>, reserve of fossil fuels is least well exploited in conventional individual service boilers. In cogeneration plant (with network distribution of hot water) the exergy reserve is used substantially more efficiently, first to generate electricity and then for the generation of heat.

Economic utilisation of degraded-quality (waste heat) energy is addressed in the present work by getting as much useful heat output from reject emission as possible, through distributed cogeneration. In this way primary fuel inputs to heating are reduced, and hence fuel imports also.

#### QUANTITY and TIMINGS

The first requirement here is to form an elementary 'energy profile' database for the largest electricity end-users, in each economic sector, in each parish. These measured (working week) 'snapshots' of end-user behaviour enable first a better understanding of the quantity (Q) and timing (T) of electrical energy needs.

In order to do this, we have taken measurements at each large end-user's site using a microcomputer based VIP SYSTEM

1. For references on Exergy see Kotas, T.J, 1985, 'The exergy method of thermal plant analysis' or

Van Gool, W and Hoogendoorn, A.J, 1990, 'Basic aspects of exergy analysis and exergy optimisation'.

3 energy analyser<sup>1</sup> (with measurements made mainly by the Writer, but a few organised and planned by the Writer and undertaken by D.Sarchet of the SEB).

The unit is a portable, lightweight device which measures electrical energy demand/consumption, with a memory pack which stores all measured data. The data stored in the memory pack can then later be transferred to a host PC where it can be displayed and processed, and enables accurate off-line assessment.

The measurement survey is the most useful function of the equipment, in which data collected at intervals preset by the operator are stored in the memory pack. An automatic survey can be programmed by the operator by presetting the memory pack with survey start and finish times, the intervals at which measurements are to be taken and operational presettings for each survey. The analyser can therefore be programmed off-site and then installed on site for the actual survey, which is fully automatic<sup>2</sup>.

Important is that when we combine the energy analyser with a host PC a number of micro-computer based energy modelling possibilities then become possible. All of which will later (Chapter 7) assist us in computer model building, as discussed earlier in Section 3.5.

1. Manufactured by ELCONTROL s.p.a. (Italy).

2. Energy surveys in general were programmed to cover a 24 hour period, each hour split into 15 minute time periods.

Quantity and timings of energy demand need to be quantified (at different times of day and also seasonally) for all of these large end-users. Our research programme therefore required the Writer to visit each site (over a three year period) and undertake energy surveys; the results of which are provided in APPENDIX C.

The measured timing data can never exactly cover the same time period (day/month/year) for each large end-user, but nevertheless provides high accuracy profile data, which is crucial to the results of good energy planning.

Many definitions of the word 'cluster' contain such statements as:

"a cluster is a set of entities which are ALIKE, and entities from different clusters are not ALIKE".

EVERITT<sup>1</sup> notes that the common feature of most proposed definitions is their vague and circular nature, in the sense that terms such as SIMILARITY, DISTANCE and ALIKE are used in the definition, but are themselves undefined. That there is no universal agreement on what constitutes a cluster; in fact it is probable that no single definition is sufficient. That the ultimate criterion for evaluating the meaning of such terms as cluster or similarity is the choice of world view (in the systems world of energy management for example, see Section 3.3). If using the term produces an answer of value to the researcher, then that is all that is

1. Everitt, B, 1974, 'Cluster analysis'.



required.

A problem common to all clustering techniques is the difficulty of deciding the number of clusters present in the data. The majority of clustering techniques begin with the calculation of distances between entities and consideration of the possible ways of defining these quantities.

The approach we use in the present work details the location of the largest electricity end-users in each economic sector, in each parish, and then takes into account their geographic disposition (clustering). This may be useful when considering (a) the summation of profiles in an attempt to 'smooth' the overall energy demand curve and (b) when attempting to match variable sources with these variable demand profiles, but this needs to be tested.

### **6.3 Abstractions of parish based QOT demands**

Our parish based abstractions (ie. the largest electricity end-users in each economic sector) of daily, and monthly/seasonal demands are provided in Figures 62-79. Each abstraction exhibits different demand profiles; energy use and supply are highly location specific. This is likely to be important in our analysis of alternative supply patterns and raises issues about the diverse nature of these parish abstractions.

Each parish abstraction alone represents a significant proportion of the total electrical energy for production,  
TABLE 6.3.

**VALE**

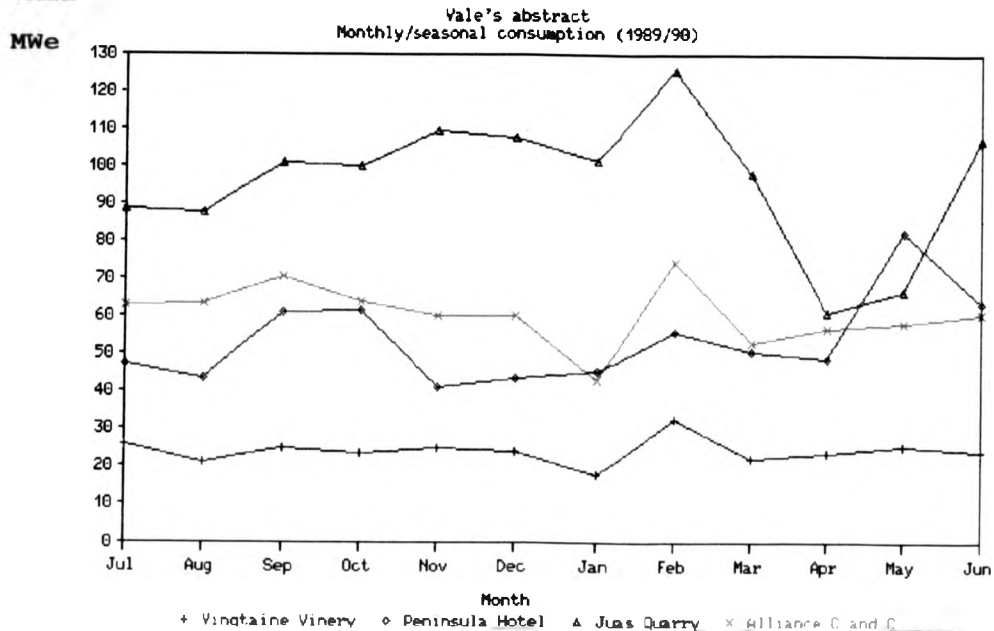

Figure 62

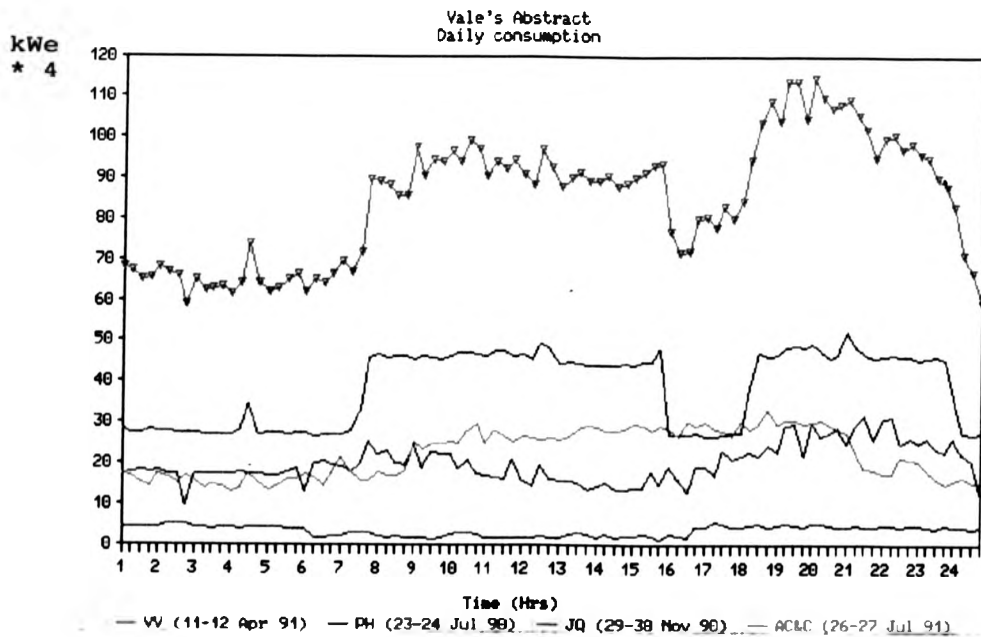

Figure 63

**ST. SAMPSONS**

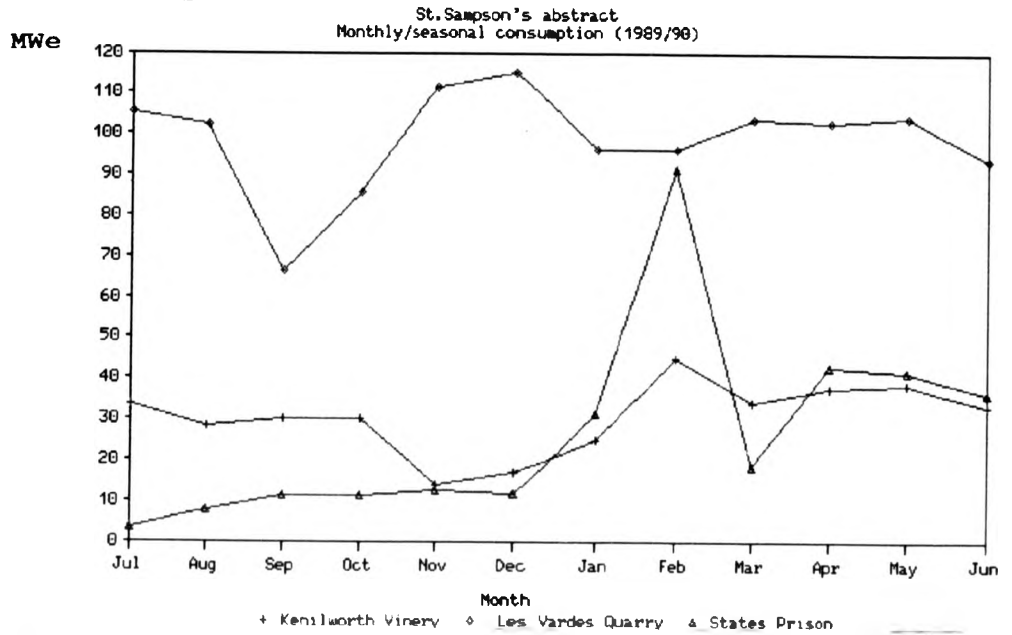

Figure 64

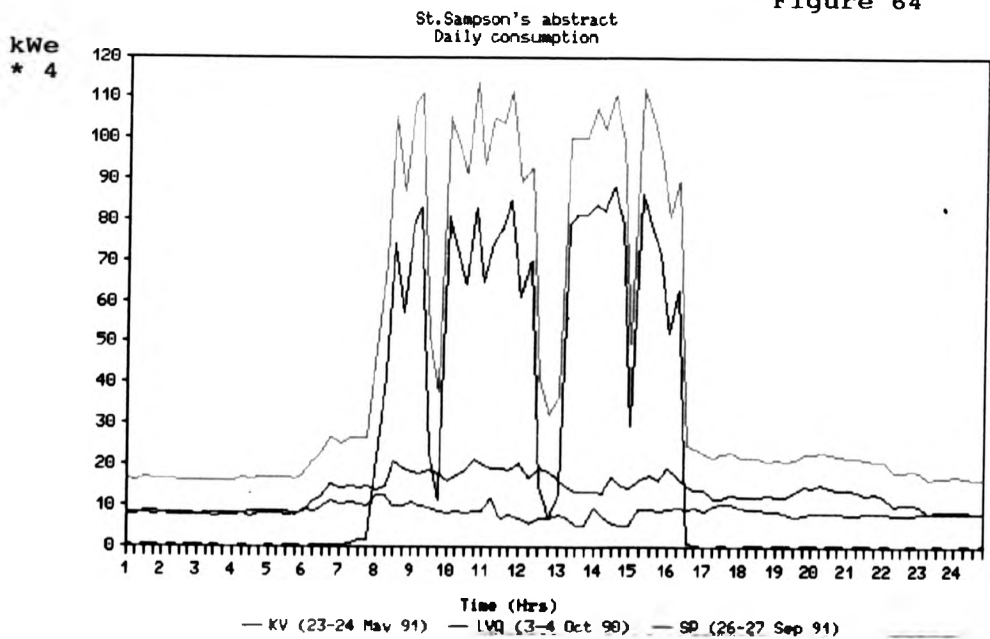

Figure 65

**CASTEL**

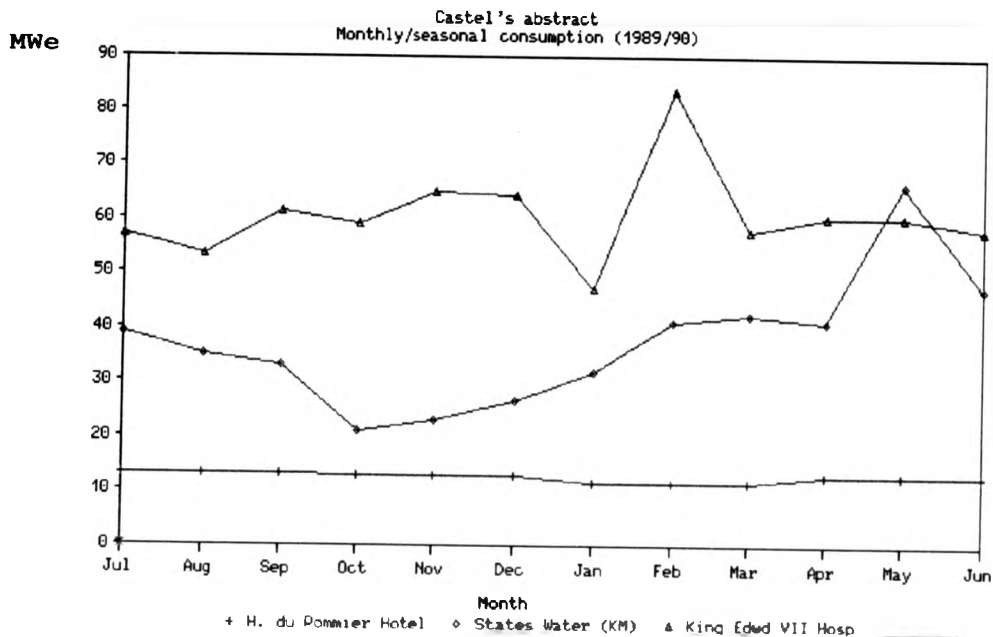

Figure 66

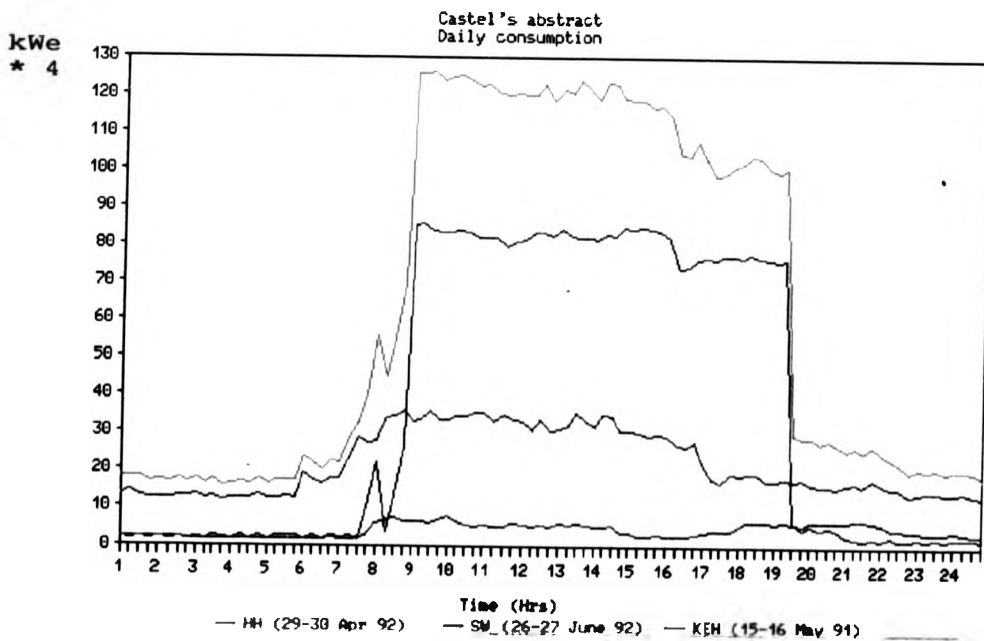

Figure 67

**ST. SAVIOURS**

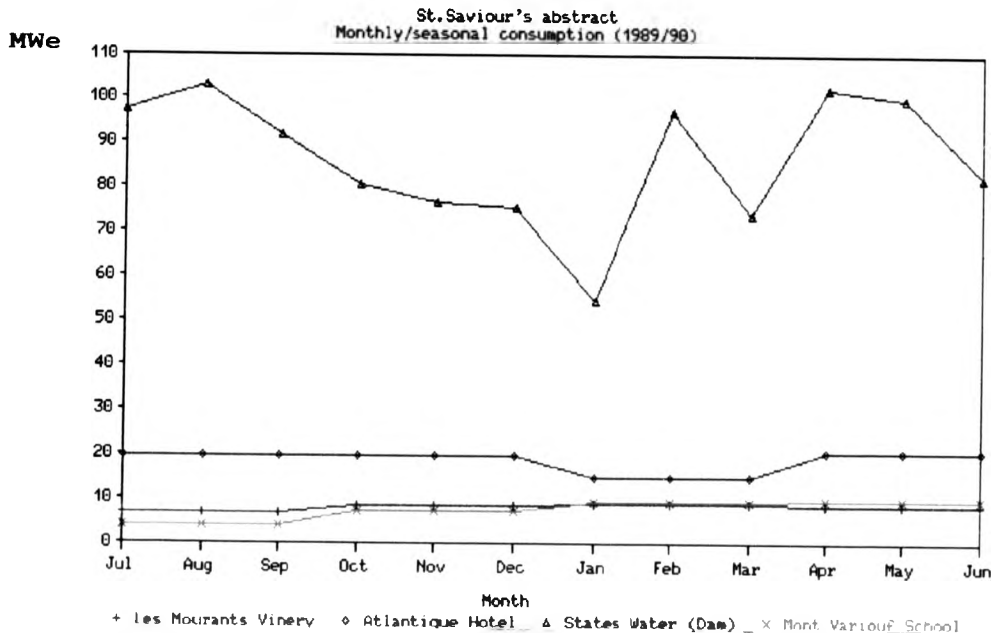

Figure 68

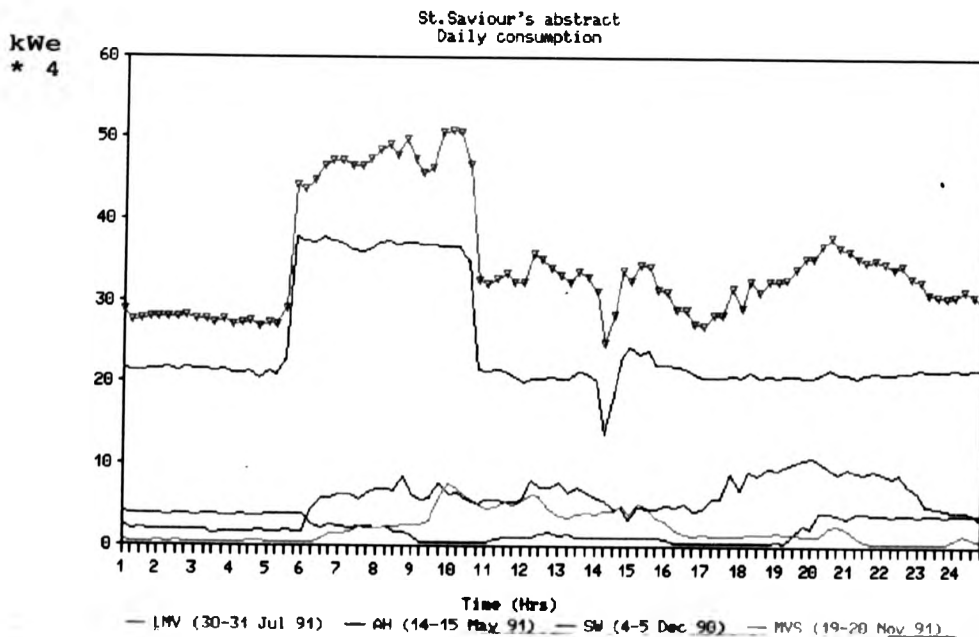

Figure 69

**ST. PETER/TORTEVAL**

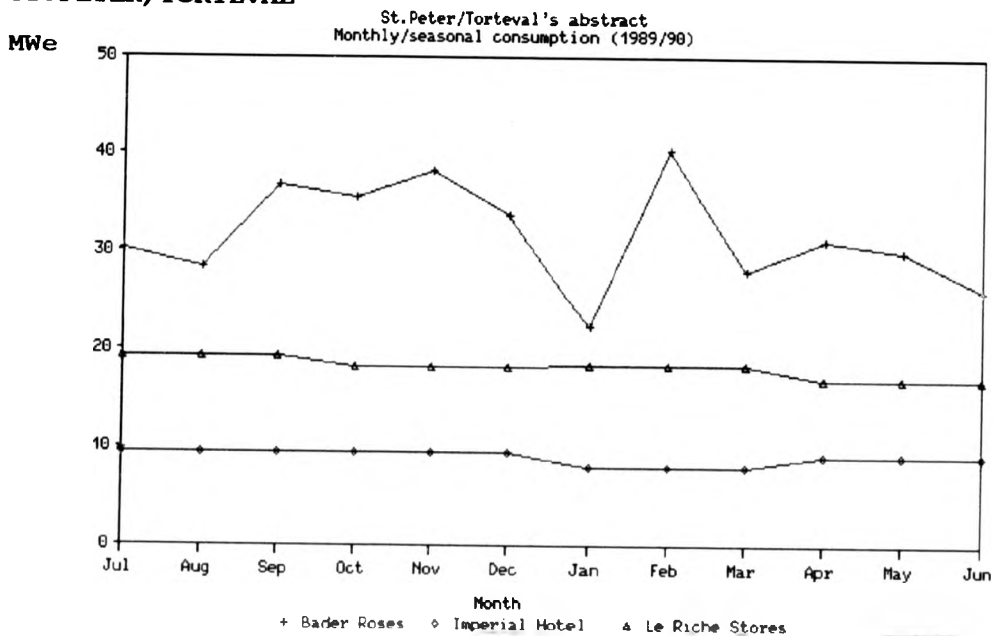

Figure 70

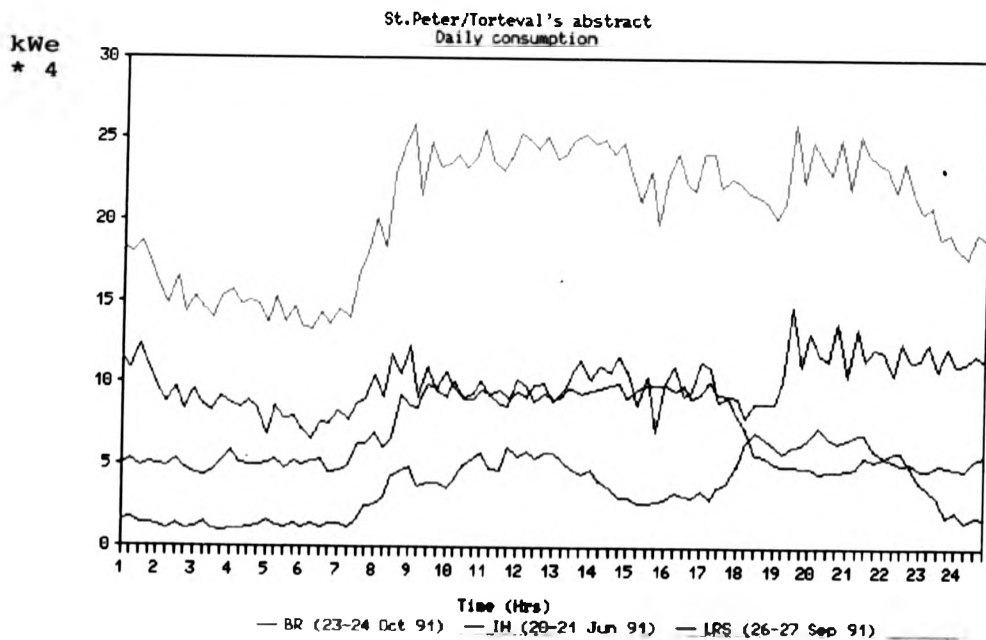

Figure 71

**FOREST**

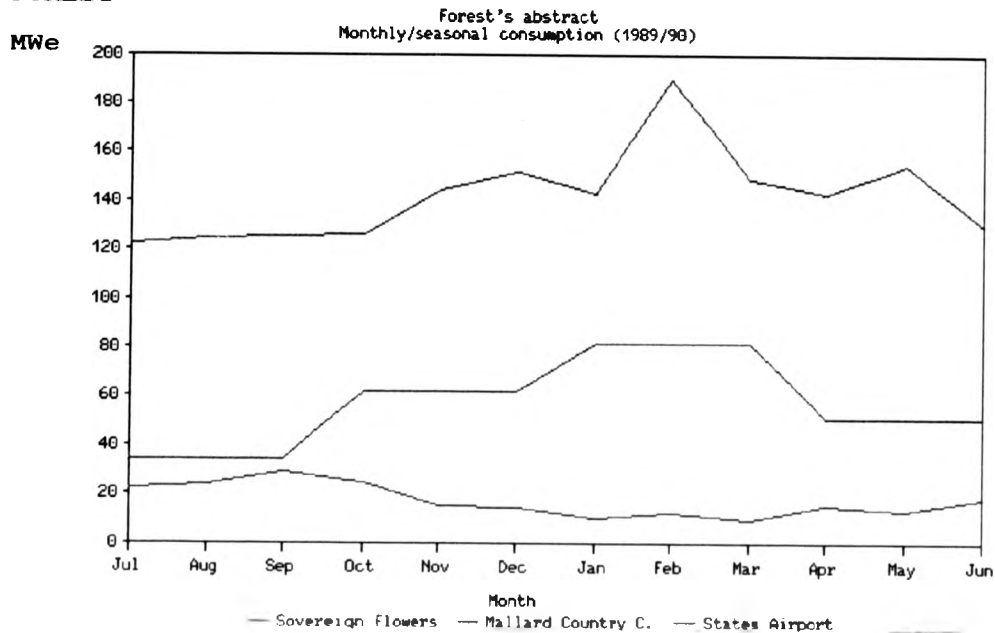

Figure 72

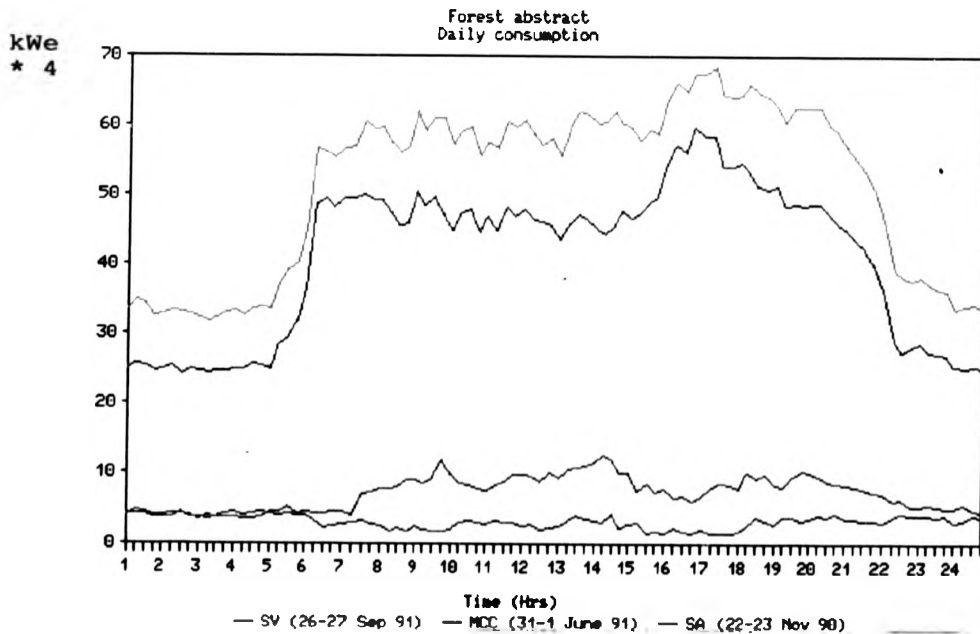

Figure 73

**ST. ANDREWS**

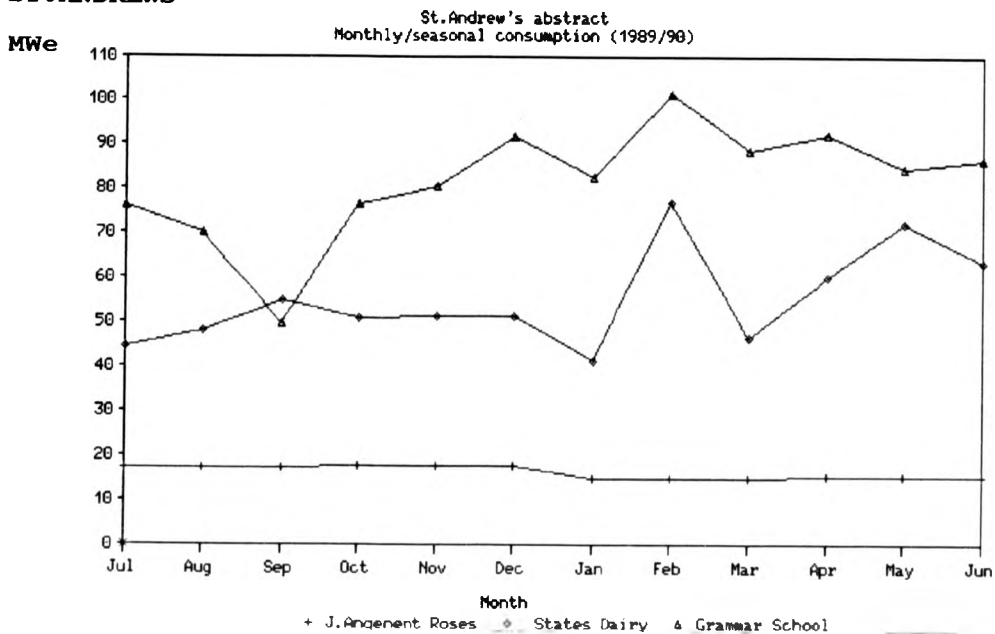

Figure 74

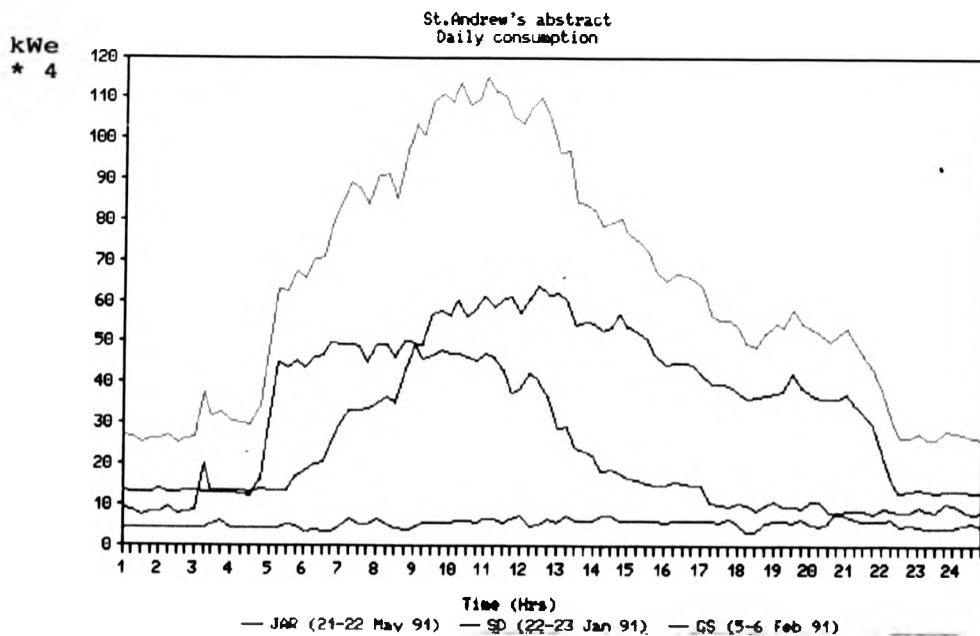

Figure 75



**ST. MARTINS**

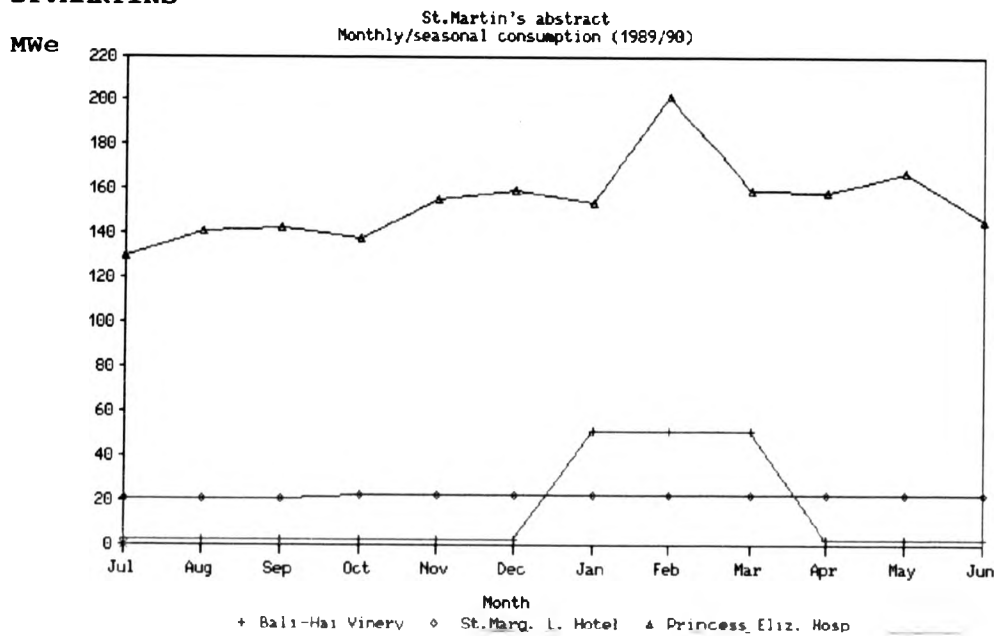

Figure 76

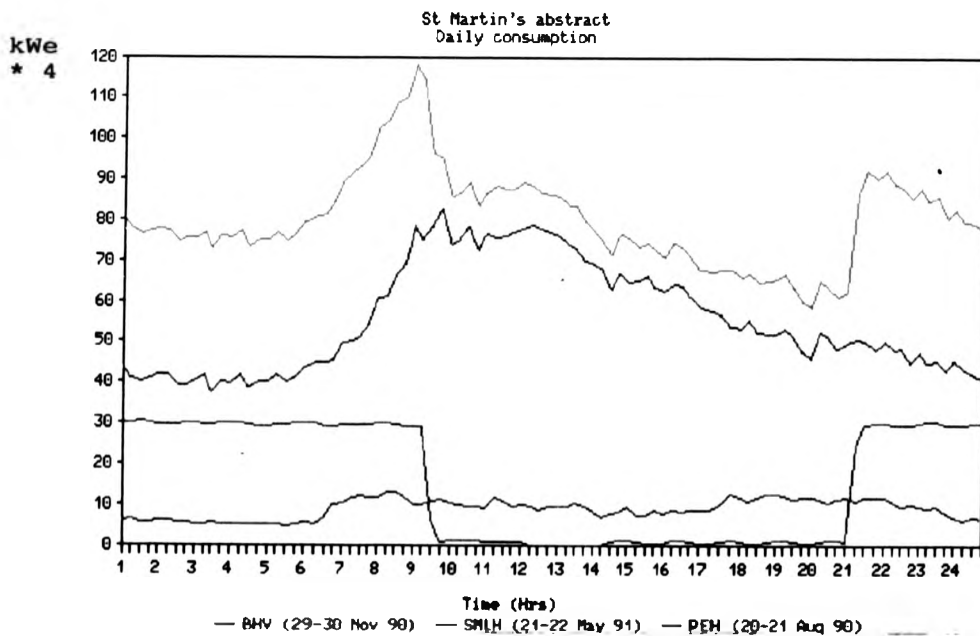

Figure 77

**ST. PETER PORT**

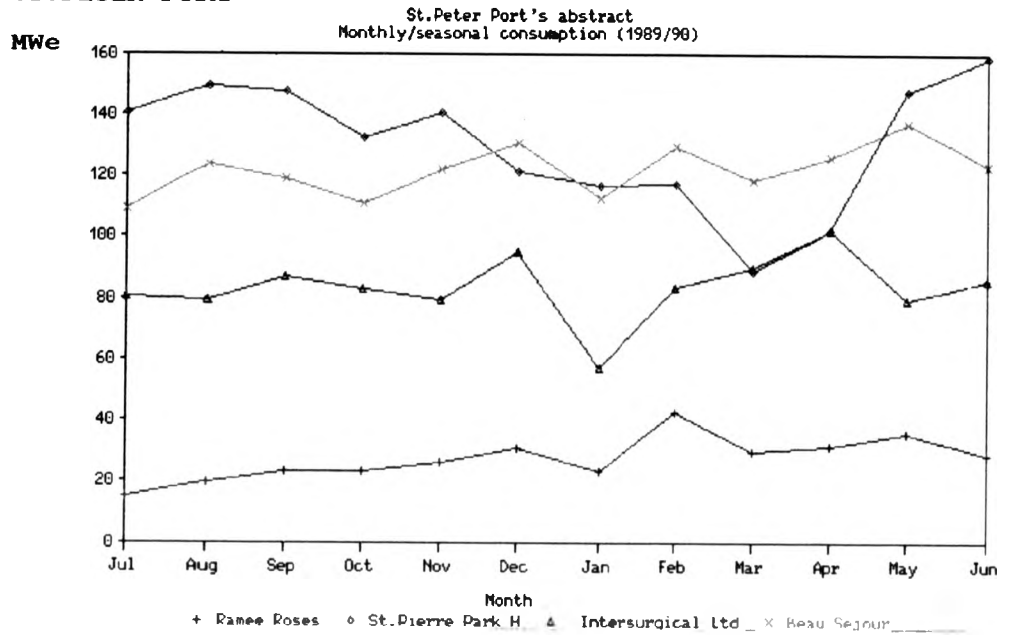

Figure 78

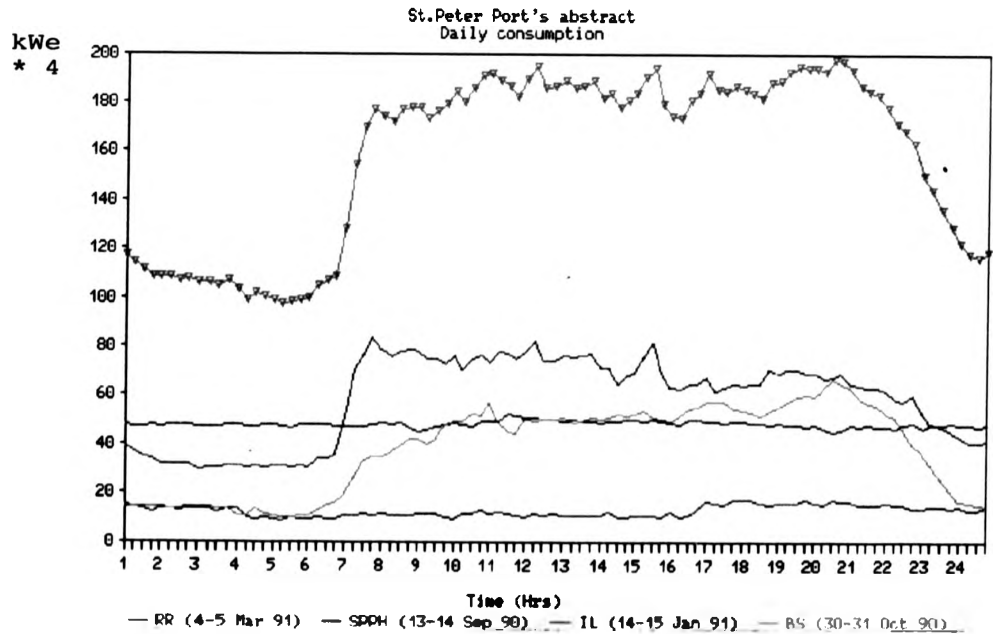

Figure 79

**TABLE 6.3 - Abstractions and their contribution to production electrical energy demand in each parish**

<b>Parish</b>	<b>% of total energy for production</b>
Vale	28%
St.Sampsons	14%
Castel	17%
St.Saviours	83%
St.Peter/Torteval	73%
Forest	58%
St.Andrews	49%
St.Martins	25%
St.Peter Port	8%

These are abstractions only, but their QQT profiles form the bedrock of the aggregate electrical energy profile of each parish<sup>1</sup>. We will show that these abstractions may, in the aggregate, be considered representative of energy end-users as a whole and from which we can develop final parish load profiles to later assist in our energy planning work.

#### **6.4 Legislation relating to the energy sector**

The energy sector presently has a duty to comply with the provisions of certain ordinance and laws implemented by the States of Guernsey, which include:-

1. Important is that end-users in the same economic sector have the same typical daily load profile (hotels and vineries for example); this will be important later.

- The Health & Safety at Work (Guernsey) Law 1979
- The Health & Safety at Work (General) (Gnsy) Ord. 1987
- The Health, Safety and Welfare of Employees 1950 Law
- The Safety of Employees (Misc. Provisions) Ord. 1952
- The Safety of Employees (Electricity Provisions) Ord. 1956
- The Safety of Employees (Woodworking Machinery) Ord. 1959
- The Safety of Employees (First-Aid & Welfare) Ord. 1954
- The Steam Boilers (Insurance) Ord. 1952
- The Public Highway Ord. 1967
- The Electricity Law 1933 and subsequent additions
- The Poisonous Substances (Gnsy) Law 1958
- The Island Development Law 1966

The Health and Safety at Work (General) (Guernsey) Ordinance 1987, Section 36 relates to the transport and storage of highly flammable fuels (Motor Spirit, Avgas, Avtur and LPG/flammable gas). All require a licence from the States Labour and Welfare Committee in order for a company to store and transport such fuels.

Important is that Gas Oil, Heavy Fuel Oil and Kerosene can be safely transported and stored at a decentralised location without such a licence. Certain precautions are required by the States Water Board with regard to oil storage (ie. a bund wall) to ensure containment, but these are minimal.

The Public Highway Ordinance 1967 relates to the opening and reinstatement of roads and footpaths on the Island. Such works are mainly carried out at present by

only four organisations (a) States Water Board (b) States Electricity Board (c) Guernsey Telecommunications and (d) Gas Energy. All organisations who carry out such road works should be in accordance with this code of practice in order to maintain the whole of the disturbed surface in a safe condition (all at their own expense<sup>1</sup>).

The Electricity Law 1933 requires compliance with the requirements for the time being of the Institution of Electrical Engineers, as set out in their rules and regulations. The Law imposes requirements with regard to the placing of electric lines across private property for example, all of which are presently administered by the States Electricity Board.

The 1966 Island Development Law and subsequent amendments and ordinances provide the framework for development control on the Island. Development is defined as "the carrying out of any building, engineering, mining or other operation in, on, over or under land and includes the making of any material change in the use of any building or land<sup>2</sup>".

The first building regulations were formed by the States Housing Authority in pursuance of the Building (Guernsey) Law 1956. This has now been replaced by new

1. Legislation to allow operators of cogeneration plant to lay piping under Island roads could easily also comply with this code of practice.

2. See paragraph 40, 1966 Law.

building regulations which came into operation on 1 March 1993, introduced by the Island Development Committee.

The Island does not currently legislate against atmospheric discharges and is not party to any U.K./ International energy sector agreements.

Legislation is widely scattered and administered through a number of different States departments (see Chapter 10).

#### SUMMARY

- (1) Band 4 energy end-users dominate demand in their location.
- (2) Economic utilisation of degraded-quality (waste heat) energy is addressed in the present work by getting as much useful heat output from reject emission as possible, through distributed cogeneration. In this way primary fuel inputs to heating are reduced, and hence fuel imports also.
- (3) An elementary 'energy profile' database is formed for the largest electricity end-users, in each economic sector, in each parish.
- (4) The geographical clustering of large end-users is considered.
- (5) Parish based abstractions indicate that energy use and supply are highly location specific.

(6) Each parish abstraction alone represents a significant proportion of the total electrical energy for production.

(7) The parish abstractions form the bedrock of the aggregate electrical energy profile of each parish.

(8) Gas Oil, Heavy Fuel Oil and Kerosene can be safely transported and stored at a decentralised site, without a licence.

(9) The Island does not currently legislate against atmospheric discharges.

## CHAPTER 7

### ENERGY MODELLING OF THE SYSTEM AND ITS COMPONENTS

Computer model building can now create a bridge between the 'Energy Market Analysis' sub-system model operated in Chapters 4, 5 & 6 and the 'Energy Planning' sub-system model to be operated in Chapters 8, 9, 10 and 11.

This Chapter considers simulation modelling at six different levels of energy service delivery. *THIS* leads to the conclusion that it is only locally that the possibilities for integrating the requirement for electrical energy with the requirement for heat energy become much clearer.

The new focus on energy planning then becomes not the aggregate Island level, which has been the norm, but the distributed level of the Guernsey parishes.

#### 7.1 Sub-systems 'bridge'

An energy resource assessment of each parish has been undertaken, which involved the identification of potential energy resources that might have an impact upon the local supply-demand balance. For example, within the parish of Forest renewable resource wind data is available which consists of measured wind speed centred on the States Airport. For the parish of Vale, solid waste data is available for the principal landfill site at Bordeaux.

Our Guernsey energy model tests the priority of



obtaining power from a cogeneration unit<sup>1</sup>, with these other possible sources treated as secondary. These other variable supplementary sources may be practicable on a site by site basis (see Chapter 9), but the order of priority will be shown to be:-

- (1) Cogenerator heat first.
- (2) Fuel-fired supplementary boiler heating.
- (3) Biofuels and wind.

From an Island perspective, the main advantages of distributed cogeneration (with hot water heating networks) may be:-

- (1) The potential to conserve energy.
- (2) The opportunity to substitute for oil.
- (3) To increase fuel flexibility and security of supply.
- (4) Improve air quality.
- (5) To focus attention on the potential of small-scale benign sources of energy.
- (6) The provision of lower priced energy tariffs related to the improved efficiency of fuel utilisation.

Some form of cogeneration provides the only way to

1. Cogeneration, also known as Combined Heat and Power (CHP) generation, is the simultaneous production of electricity and heat from a single power plant. Here the term is used to describe medium speed, diesel engine based CHP.

See Borlock, J.H., 1987, 'Cogeneration: Combined heat and power' for example.

achieve the highest possible efficiency of prime fuel use from a generator installation. Traditionally cogeneration schemes were devised around steam turbine plant, but in more recent times diesel engines and gas turbines have been employed. These prime movers offer a lower heat to power ratio than the boiler-steam turbine but are much more available in smaller, flexible and modular sizes<sup>1</sup>.

A variety of waste heat recuperation processes are available, with the heat recoverable over a range of temperatures depending on the chosen technology. Figure 81 and TABLE 7.1 provide the basic parameters for diesel and gas turbine cogeneration plants.

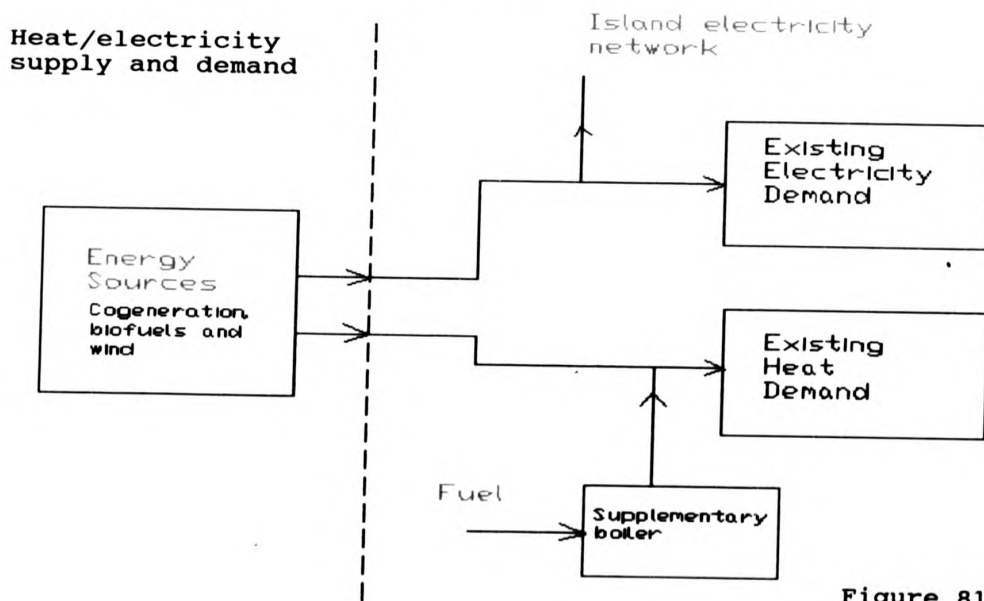

Figure 81

1. See for example Hein, K, 1982, 'Local power and heat generation in Heidenheim and West Germany'. Compared to normal district heating installations modular cogeneration plants require less capital investment, have higher overall degrees of utilisation and can be matched to the requirements in small stages.

TABLE 7.1 - Basic cogeneration parameters<sup>1</sup>

	Heat/power ratio	Available temp. (C)
<b>Diesel engine:</b>		
With waste heat boiler <sup>2</sup>	0.5 - 1.7 : 1	200 +
With boost fired boiler <sup>3</sup>	3 : 1	200 +
<b>Gas turbine:</b>		
With waste heat boiler	1.4 - 2.8 : 1	250 +
With boost fired boiler	9 : 1	250 +

#### Diesel engines

Small diesel engines up to 1 MWe burn only clean distillate fuels such as Gas Oil, while larger engines can be designed to burn Heavy Fuel Oil. Regardless HFO has to be heated and treated before delivery to the engine, thus adding to the operational and capital costs.

In general terms very high speed diesel engines (> 3000 rpm) are used only in vehicle applications; three

1. See for example Bill, C, 1989, 'The application of diesel engine and gas turbine prime movers to Combined Heat and Power' of the Energy and Economics Division, Herz and McLellan, Newcastle-upon-Tyne + personal communication.
2. As heat to power ratios are increased in cogeneration design, the total efficiency falls off. In general, the present study uses a heat/power ratio of 1.4, with an electricity conversion efficiency of 35% (see Sections 9.1 and 11.5).
3. The exhaust gases contain oxygen, and so fuel can be burnt in the duct carrying these gases to the heat recovery boiler. This raises the temperature of the gases and increases the heat available, without the need for additional air.

speed groups are applicable to power generation<sup>1</sup>:-

- |                     |   |              |
|---------------------|---|--------------|
| (1) 1000 - 3000 rpm | - | High speed   |
| (2) 400 - 1000 rpm  | - | Medium speed |
| (3) up to 400 rpm   | - | Slow speed   |

Only some 30-40% of the energy in the fuel is converted into electricity, with 6-8% consumed by auxiliary plant and in the generator. A further 2-5% is radiated from the hot surfaces of the engine and the engine exhaust. Of the remaining 55%, about 20% is transferred to the engine cooling water circuits and 35% into the engine exhaust<sup>2</sup>.

Without cogeneration, about 30-40% of the energy in the fuel is employed to generate electricity; with cogeneration the useful portion may rise to about 85%.

#### Gas turbines

Gas turbines are limited to the use of clean distillate fuels and/or gas, and are available in outputs from about 1 MWe to well over 100 MWe. Gas turbines for cogeneration are usually single shaft machines (ie. the compressor and turbine stages are solidly joined together) rotating at 6000 rpm or more and driving a generator via step-down gearing.

1. Only where differences are significant to overall economic performance will reference be made to the technical variants involved.
2. With diesel engine exhaust gas temperatures in the order of 350-400 C.

17-28% of the energy in the fuel is converted into useful electrical output and between 10-20% is consumed in driving auxiliary machinery and in generator loss. The remainder, 62-73%, is carried away in the exhaust gases.

Without cogeneration about 17-28% of the energy in the fuel is employed to generate electricity; with cogeneration the useful portion may be increased to a maximum of about 65%.

## 7.2 Computer model building

It was not until the end of the 1970s that personal computers (PCs) were first applied in energy work. With a few exceptions, before the 1980s almost all assessments and planning studies (if they used computers at all) relied on mainframe equipment.

A TurboPascal simulation programme was first considered in the present work, which was first produced by Jacques et al<sup>1</sup> in the 1980s, which investigated some of the problems of design-choice for cogeneration and allowed experimentation with various mixes of energy sources (cogeneration, solar and wind). Simply, its user-friendliness and graphical presentation are poor, and further developments in support environments and graphical techniques have radically changed model construction, and it

1. Jacques, J.K and Konis, C.Y (with computer technical assistance from Muir, A and Mitchell, C), 1989, 'Systems modelling and micro-computing applied to mediterranean hotel energy conservation planning through cogeneration simulations'.

was rejected in the present context.

Computer model building<sup>1</sup> and simulation studies are primarily directed towards finding satisfactory solutions to practical problems, where stochastic variables are involved (eg. Monte Carlo methods for example, there are others<sup>2</sup>).

Personal computing assists the researcher to become much more organised in energy planning work and encourages the energy planner to develop far more extensive and better quality data. Recent developments in computer based measuring technology for example are particularly valuable in the modelling phase. In particular, the ready ability to undertake end-user site energy surveys are much enhanced.

There are a number of other (large) cogeneration computer models available, but we do not intend to provide an exhaustive coverage of them nor an extensive description of all aspects, others have done so, see Hu<sup>3</sup> for example. In contrast the present work concentrates on these more recent developments in computer based energy survey techniques, and attempts to build an original Guernsey energy model, which is more appropriate to the class of very small islands with which we are concerned.

1. Some of the relevant skill areas for model construction are (a) business analysis (b) human-computer interface design (c) software design (d) database design (e) performance evaluation and (f) computer system configuration.
2. See Neelankavil, P, 1987, 'Computer simulation and modelling' for example.
3. Hu, D.S, 1985, 'Cogeneration'.

APPENDIX D describes the support environments and graphical techniques used in the present work.

The use of micro-computers in energy planning work can be grouped into three main areas<sup>1</sup>:-

- 1) Models that address the linkages between the macro-economy and the energy sector.
- 2) Energy sector models for such tasks as the preparation of national energy balances.
- 3) Detailed sub-sectoral models.

The level of aggregation is a key decision that must be made in the design and implementation of an energy model. Disaggregation has a price; it can be enormously time consuming obtaining reliable data inputs, but even then no one model can be disaggregated in enough detail to be capable of answering all questions. Nonetheless, this may be essential to a thorough (QQT) approach.

**An essential ingredient in constructing an end-use QQT model is a set of reliable profiles.**

Chapter 6 provided the detailed abstractions for each parish on Guernsey, using the micro-computer based energy measuring techniques described earlier. This large amount of detailed (reliable) data can now be used as the basis for an

1. See Capros, P et al, 1988, 'Energy policy analysis'. Where models, databases, quantitative tools and their integration within a consistent framework (usually computerised) are discussed.

initial (simplistic) modelling exercise for each parish. Further meta modelling/scenario evaluations can then be developed leading to a final parish model.

From the initial model, the maximum electrical load profile for each economic sector can be estimated using a ratio estimator, with annual electricity consumption as the auxiliary variable. It determines the profile by using economic sector electricity consumption (a precise quantity), whereas less detailed end-use models effectively make use of the number of end-use penetration rates of appliances etc. Which often (and certainly in our case) are not clearly defined. Further research work on Guernsey is required to clearly define these end-uses (covering all economic sectors), but this type of detail is not wholly relevant for the purposes of the present work.

The main building block for our modelling is the electrical energy QOT profile for each major end-user, in each economic sector, within each parish.

### 7.3 Methodology of the Guernsey energy model

The Guernsey energy model methodology is given in Figure 81; parish based energy demand is met by parish based energy supply sources.

There are three principal reasons 'why' the energy model (based on the Guernsey parishes) was built in this way:-

- 1) Because of the need to decentralise and model energy clusters closer to the end-user.



2) In terms of data availability of all types, parish data is more readily accessible.

3) Because the political system within the Island is based on rigid parish representation (see Chapter 1) and this may influence the uptake of alternative energy use/supply technologies, locally.

### Energy Model Methodology

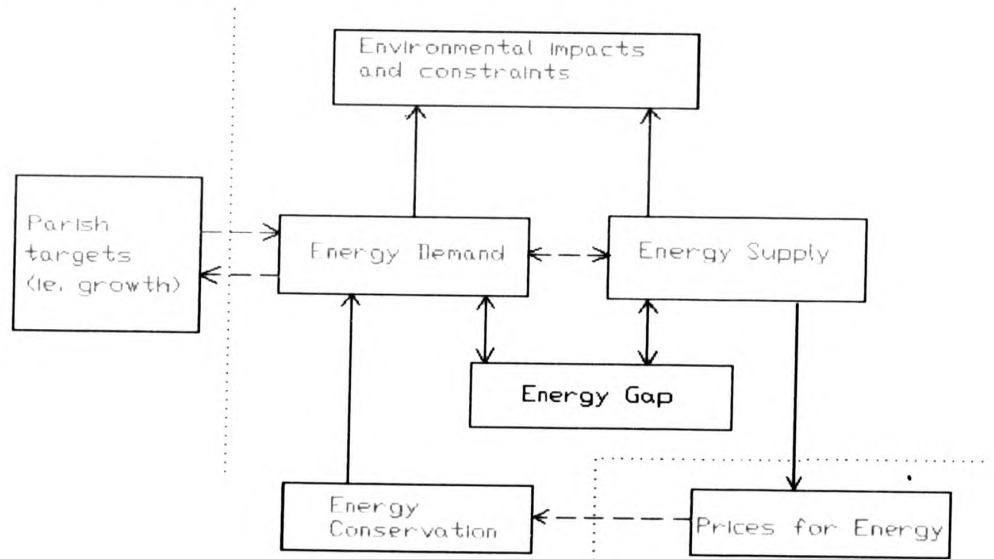

Figure 81

The energy model was developed in four stages:-

- (a) Definition
- (b) Construction
- (c) Testing
- (d) Application

(a) Definition

A powerful feature of current spreadsheets (such as SuperCalc 5) is the ability to use more than one spreadsheet at a time (ie. multi-page). Each parish cluster/model has two pages, Figure 82.

### Parish Spreadsheet Model

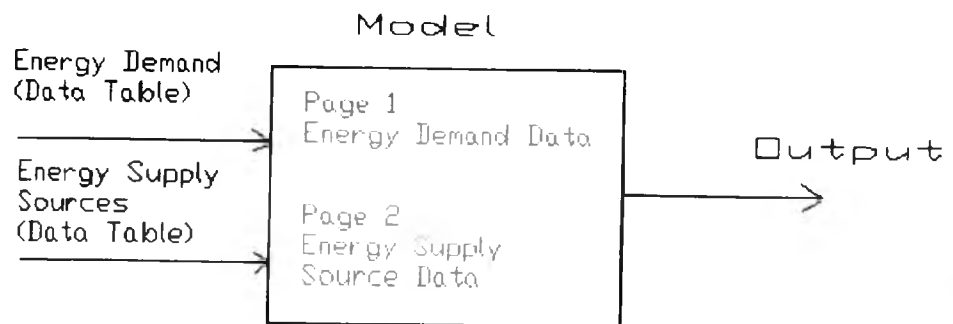

Figure 82

Page 1 of the spreadsheet model consists of a 24 hour energy demand table, each hour split into 15 minute time periods. A two hour sample of a typical demand table is provided in Figure 83 as an example<sup>1</sup>.

Electrical energy survey data from a number of sites can be loaded into the page 1 demand table from a spreadsheet template (via a 3.5" floppy disk<sup>2</sup>).

1. End-user energy demand is averaged over a 15 minute interval of time.
2. Page 1 references the same cells on the spreadsheet template (a technique known as spreadsheet linking). This methodology has been designed by the Writer, and is not part of the energy measuring equipment described in Section 6.2.

HEAT		1		2	
kkht # 4					
DOMESTIC	0	0	0	0	0
COMMERCIAL	0	0	0	0	0
VINERIES	0	0	0	0	0
TOURISM	0	0	0	0	0
INDUSTRIAL	0	0	0	0	0
TOTAL	0	0	0	0	0
ELECTRICITY					
kkhe # 4		1		2	
DOMESTIC	0	0	0	0	0
COMMERCIAL	25.18525	25.8045	25.4395	24.78475	24.9545
VINERIES	4.1475	4.8675	4.6025	4.1375	4.1675
TOURISM	4.4075	4.225	4.4025	3.8425	3.7875
INDUSTRIAL	0	0	0	0	0
TOTAL	33.74025	34.897	34.4445	32.76475	32.9095
TOTAL					
kkh # 4		1		2	
HEAT	0	0	0	0	0
ELECTRICITY	33.74025	34.897	34.4445	32.76475	32.9095
TOTAL	33.74025	34.897	34.4445	32.76475	32.9095

Sample showing two hours of typical electricity demand table for the Forest (see Figure 73; measurements at 15 minute intervals); the heat demand table has been added, to be used later in our QQT heat/power ratio model building.

Figure 83

Page 2 of the spreadsheet model also consists of a 24 hour supply source table, again each hour split into 15 minute time periods. Supply source data can then be similarly loaded into the model.

The advantage of this multi-page spreadsheet approach is that page 1 (energy demands) and page 2 (energy sources) use formulae that cross-refer to data on the other page. Informing the user if energy supply > energy demand (energy gap analysis) for example, over each 15 minute time period.

(b) Construction

The basic structure of the Guernsey energy model was constructed in the form of a menu driven integrated package, covering all parishes. This was produced using the programming language dBASE III Plus (source code programs are provided in APPENDIX E).

The energy model is started by an executable file (PhD.EXE) which presents the opening screen to the operator, and is followed by the entry screen, which indicates much about the approach in this Chapter, Figure 84.

**Meta Modelling**  
**- Scenario Evaluation**  
-----

1. Introduction
2. Parish clusters
3. Final parish models
4. Energy and financial analysis
5. Simulation
6. 30 year life-cycle ESCos

Figure 84

The selection of (2) for example produces a sub-menu entitled 'Parish clusters', Figure 85, which details the Guernsey parishes in anti-clockwise rotation around the Island.

**Parish clusters**  
-----

1. Vale
2. St Sampsons
3. Castel
4. St.Saviour
5. St.Peter/Torteval
6. Forest
7. St.Andrew
8. St.Martin
9. St.Peter Port

Figure 85

The selection of a **parish cluster**, say (6), displays the first page of the model relating to the Forest. Heat/electricity, demand/supply source scenarios for this parish cluster can then be simulated and stored on individual spreadsheet templates and loaded into the model, as and when required.

Similarly from the main menu, the selection of (3) displays the first page of a **Final parish model**; (4) an **Energy and financial analysis** of each final parish model; (5) **Monte Carlo Simulation<sup>1</sup>** of parish wind power (see Chapter 9) and (6) an energy and financial analysis of **30 year life-cycle ESCos** (see Chapter 11).

1. The existence of spreadsheet support enables the analysis to include renewable supply source uncertainty which allows the energy modeller to come closer to an improved 'meta-reality'.

Each selection is followed by a sub-menu of the Guernsey parishes (similar to 'Parish clusters').

(c) Testing

Energy modelling proceeds by equating the total electrical energy demand with the supply of electrical energy, from whatever source is available.

The Guernsey energy model thus provides an energy planning environment for each parish on the Island, where different levels of energy service delivery can then be simulated. The process of modelling for the parish of Forest is demonstrated in Section 7.5, as an example of our approach.

(d) Application

The output from the simulation work can then be utilised in a number of ways:-

1) First it informs the user whether energy demand is greater than or less than energy supply over each of the 15 minute time periods of a typical working day (energy gap analysis). From this a view can be taken as to modular plant choices.

2) It allows the user to take individual economic sector demand profiles and add them together to produce parish abstractions (as described in Chapter 6).

3) It then enables parish abstraction QOT demands to be ratio estimated, with annual electricity consumption used as the auxiliary variable. From this we will show that a view

can also be taken as to modular cogeneration and boiler plant choices available to possible (parish) energy service companies, see Chapter 9.

Electricity AND heat demands can now be modelled (with the focus on real energy planning rather than merely just electricity provision).

4) It provides a graphical presentation of the variability of demand, which can be used to attempt to smooth demand curves (for example, by the introduction of electric vehicles), see Chapter 9.

5) It provides the expected contribution from wind power for each of the Guernsey parishes, using Monte Carlo simulation techniques, see Chapter 9.

6) It holds energy, operational and capital cost estimates for a range of modular plant scenarios, see Chapter 11.

7) It produces estimated electricity/heat tariffs for each (parish) energy service company, see Chapter 11.

#### **7.4 The process of modelling**

##### **The QQT DEMAND model**

The step by step construction of an electrical energy QQT DEMAND model for the parish of Forest for example proceeds as follows:-

**STEP 1 - Construct a demand table for the Forest abstraction, which consists of three sites, the States Airport (C), Sovereign Flowers (V) and the Mallard Country**

Club (T) (no industrial).

STEP 2 - These three sites explain 58% of the total production consumption in the Forest (see TABLE 6.3). The requirement now is to expand the model to explain the remaining 42%.

Important is that our energy survey work suggests that the timing profiles for hotels are very similar. See APPENDIX F for example, which compares the QQT profiles for two other Island hotels, the OGH in St.Peter Port and Le Trelade in St.Martins.

The quantity of electrical energy consumed is mainly dependent upon the hotel's size (ie. the number of beds). There are 14 hotels/guest houses in the Forest, the largest is the Mallard Country Club (99 Beds), Table 7.2.

TABLE 7.2 - Forest tourism sector (1990)

	Electrical energy end-users	Total kWhe
Band 1 -	0	0
Band 2 -	0	0
Band 3 -	12	360,452
Band 4 -	2	328,564 <sup>1</sup>

In order to model the remaining 13 profiles the Mallard Country Club daily QQT profile is taken and multiplied by a ratio estimator according to the annual

1. Of which Mallard Country Club = 219,128 kWhe



electricity consumption of the other end users (ratio estimator = 3.1).

This approach can also be applied to the vinery sector. See APPENDIX F, which also compares the QQT profiles for two other Island vineries, Vingtaine in Vale and Bader Roses in St.Peter/Torteval.

There are 68 vineries in the Forest, the largest is Sovereign Flowers, Table 7.3 (ratio estimator = 1.71).

TABLE 7.3 - Forest vinery sector (1990)

	Electrical energy end-users	Total kWhe
Band 1 -	16	2,144
Band 2 -	39	84,248
Band 3 -	11	235,576
Band 4 -	2	947,379 <sup>1</sup>

The commercial/public building sector comprises private and public services. In the Forest the States Airport dominates the sector and explains 65% of the sector's electricity consumption, Table 7.4 (ratio estimator = 1.55).

1. Of which Sovereign Flowers = 740,180 kWhe

TABLE 7.4 - Forest commercial/public building sector (1990)

	Electrical energy end-users	Total kWh
Band 1 -	4	388
Band 2 -	28	74,236
Band 3 -	27	471,832
Band 4 -	5	2,088,908 <sup>1</sup>

STEP 3 - The data in the demand table from step 2 (production consumption) can now be added to total domestic electricity demand<sup>2</sup>.

Typical diurnal domestic electricity demand profiles for each consumption band have been kindly provided by the U.K. Electricity Association<sup>3</sup>. Who have undertaken extensive domestic load research; the diurnal electricity profiles relate to unrestricted domestic customers for a winter weekday demand at 42 F and are provided in APPENDIX G.

The estimated domestic demand profile for the parish of Forest can now be determined by multiplying each band profile by the number of consumers in each band, TABLE 7.5.

1. Of which States Airport = 1,705,560 kWh
2. The lifestyle pattern on Guernsey is somewhat similar to the U.K. mainland.
3. Allera, S, Personal communication, 13 July 1992. Load research manager, U.K. Electricity Association.

Electricity Association research data indicates that the domestic profile varies little throughout the U.K..

**TABLE 7.5 - Forest domestic sector (1990)**

	Electrical energy end-users	Total kWhe
Band 1 -	18	2,212
Band 2 -	396	1,671,896
Band 3 -	73	969,992
Band 4 -	0	0

The summation of production and domestic profiles thus produce the overall diurnal (final) parish (Forest) electricity demand profile.

To model seasonal domestic electricity consumption we use the data derived directly from the Pareto analysis of the SEB billing database (see Chapter 6). The database was asked to output average quarterly electricity consumption for each parish for 1990, in four bands; TABLE 7.6 provides the results of this analysis.

**TABLE 7.6 - Average quarterly domestic electricity consumption for each parish (1990)**

Parish	Band 1		Band 2		Band 3	
	Users	kWhe	Users	kWhe	Users	kWhe
Vale	103	2571	2997	3086189	306	806316
St.Sampsons	81	1800	2633	2620108	277	754646
Castel	62	1287	2658	2764214	326	909396
St.Saviour	28	1022	703	748234	127	390522
St.Peter/Tort	34	939	901	956109	178	522152
Forest	18	553	396	417974	73	242498
St.Andrews	14	418	659	690790	122	369707
St.Martins	38	1109	1834	1867485	304	916989
St.P.Port	221	6194	5405	5279340	706	2126770
<b>Total</b>	<b>599</b>	<b>15893</b>	<b>18186</b>	<b>18430443</b>	<b>2419</b>	<b>7038996</b>

For the Forest, the average quarterly electricity

consumption is 1357 kWhe per household. From an analysis of the database (in general) the quarters of Nov/Dec/Jan & Feb/Mar/Apr appear to result in twice the consumption of May/June/July & Aug/Sep/Oct. Therefore, for seasonal domestic electricity modelling purposes we use quarterly consumption figures of 1810 kWhe and 905 kWhe respectively. Similarly for each of the other parishes; all of which we use later in QQT modelling (see Chapter 9).

#### **The QQT SUPPLY model**

We now consider the construction of a Forest QQT SUPPLY model, which enables a dispersed (smaller scale) electricity cogeneration system to be modelled, along with heat availability.

A number of researchers<sup>1</sup> have discussed demand side load management, energy efficiency, carbon and energy taxes etc, but have not really addressed in detail the 'macro-economic' justifications for strategic energy conservation management on very small islands<sup>2</sup>.

In order to correct this, our approach to energy source modelling is, in essence, seeking to optimise energy

1. See Newborough, W and Probert, S.D, 1990, 'Intelligent automatic electrical load management for networks of major domestic appliances' and

Kempton, W and Neiman, M, 1987, 'Energy efficiency: Perspectives on individual behaviour' and

Manne, A.S and Richels, R.G, 1993, 'The EC proposal for combining carbon and energy taxes'.

2. Maybe because the quality of data has not been so readily available.

services at more carefully defined levels of delivery. One level of delivery could be based upon one supply source supplying the whole parish, another level could be 633 individual energy sources. Any other intermediate level of delivery being determined by the number and size of identifiable geographic energy clusters.

Important is that the opportunities for 'peak smoothing' diminish as the level of delivery chosen is reduced<sup>1</sup>.

As well as supplying electrical energy demands the other major energy demand, which is for heat, can now be considered locally. It is locally that the possibilities for integrating the requirement for electrical energy with the requirement for heat energy become much clearer. Heat demand data was obtained from each of the three major abstraction sites in the form of monthly oil product deliveries.

#### **Modelling at different levels of energy service delivery**

Six different levels are modelled, but not all are necessarily relevant within each parish.

The first two levels of energy service delivery are defined as follows:-

**Level 1** - Each site within the parish abstraction (States Airport, Sovereign Flowers and Mallard Country Club) have their own individual supply source/sources.

1. Disaggregation should not proceed to the point where smoothing is lost.

Level 2 - All three sites are supplied from only one location, the States Airport<sup>1</sup>. The necessary heat distribution network is shown on a map background centred on the Airport site, Figure 86.



Figure 86

Scale: 1 cm = 70 m

**Digitised map of the central area of the parish of Forest**

- 1 - States Airport
- 2 - Sovereign Flowers
- 3 - Mallard Country Club

**Levels 3, 4 and 5**

These three further levels attempt to investigate the 'peak smoothing' effect, which is dependent upon:-

- 1) The comparison and integration of different types of

1. Important is that the site is wholly owned by the States of Guernsey.

end-user profile from different economic sectors (Level 3 = total production demand for example).

2) The identification of any geographic energy clusters of production and/or domestic consumption within the parish (Level 4 = total domestic demand and Level 5 = interactions with neighbouring energy clusters for example).

#### Level 6

At level 6 the model is expanded to include the total production demand of 146 energy consumers (14 hotels, 68 vineries and 64 commercial/public buildings) and all 487 domestic energy end-users.

This level of delivery is a parish energy service to ALL energy end-users, centred on the States Airport; parish based energy production and distribution as a joint service. The company offering a hot water distribution service which requires that the conventional electricity utility becomes involved with another kind of business that is (and must always be) twice as large as its primary purpose if it is to produce 1 kWhe of electricity for every 2 kWht of heat supplied.

The energy demands at all six levels are variable; the intention is to match these variable demands with possible energy sources, which may also be variable. Especially if they involve surpluses of waste heat, or wind energy uptakes for example.

### 7.5 Cogeneration planning

Investment appraisal is a crucial activity for any business, for two reasons. First, because the scale of the resources involved are usually such that the company's survival may be threatened if the results turn out badly. Second, because the decisions are largely irrevocable.

Individual projects can be described in terms of their anticipated cashflows, and the task is to decide whether these cashflows make the project in itself acceptable. A number of economists, operational researchers and financial analysts have researched and published in this field<sup>1</sup>.

#### Criteria of investment appraisal

These are (a) pay-back period (b) return on original investment (c) discounted cash flow and (d) internal rate of return.

Discounted cash flow (or DCF) is an investment appraisal technique which takes into account the time value of money over a projects's life, and is its principal advantage over the other criteria, and why we use it in the present work.

There are two important points about DCF:-

(1) DCF looks at the cash flows of a project, not the accounting profits; DCF is concerned with liquidity, not profitability.

1. See Pike, R, 1982, 'Answers without questions' for example.



Cash flows are considered because they show the costs and benefits of a project when they actually occur. For example, the capital cost of a project will be the original cash outlay (Year 0), and not the notional cost of depreciation which is used to spread the capital cost over the asset's life in the financial accounts (see Chapter 11).

(2) The timing of cash flows are taken into account by discounting them.

The effect of discounting is to give a bigger value per £1 for cash flows that occur earlier. £1 earned after one year will be worth more than £1 earned after two years, which in turn will be worth more than £1 earned after five years, and so on.

Net Present Value (NPV) is the value obtained by discounting all cash outflows and inflows of a capital investment project by a chosen target rate of 'cost of capital'.

The NPV is thus calculated as the PV of cash inflows minus the PV of cash outflows:-

(1) If the NPV is positive<sup>1</sup> - it means that the cash inflows from a capital investment will yield a return in excess of the cost of capital.

(2) If the NPV is negative - it means that the cash inflows

1. For most companies the shareholders' interests and increasing the value of the business take highest priority.

from a capital investment will yield a return below the cost of capital, and so the project should not be undertaken.

(3) If the NPV is exactly zero - the cash inflows from a capital investment will yield a return which is exactly the same as the cost of capital (ie. the 'Internal Rate of Return'), and the project only just worth undertaking.

Important is that the positive NPV criteria is subject only to capital rationing and the feasibility of another project of higher NPV<sup>1</sup>.

There are however other reasons why a present £1 is worth more than a future £1:-

(1) Uncertainty - the business world is full of risk and uncertainty and although there might be a promise of money to come in the future, it can never be certain that the money will be received until it has actually been paid.

(2) Inflation - £1 now is worth more than £1 in the future because of inflation, but the time value of money concept applies even if there is zero inflation. Inflation increases the discrepancy in value between monies received at different times but it is not the basis of the concept.

The rate of discount<sup>2</sup> is crucial to the outcome, many

1. See for example the ranking discussion in Chapter 11.

2. Different discount rates give different present worths. A high rate will reduce substantially the present worth. The cost of capital is always likely to be a somewhat arbitrary figure but should be regarded critically.

writers identifying this with a company's cost of capital (ie. some measure of the cost to the company of the funds that it uses to finance its investments). To some extent this cost (of capital) reflects the inherent riskiness of the project. This is the 'uncertainty' argument for discounting<sup>1</sup>; a complex debate which we do not review here (but discount rates are again discussed in Chapter 11).

VAT is excluded from our appraisals, because this tax is not levied on the Island nor corporation tax which is not levied on States of Guernsey Trading Boards (such as the States Electricity Board for example).

Our analysis uses constant value money in all DCF evaluations (the discount rate includes inflation), with a base year of 1992.

Taking account of the time value of money (by discounting) is one of the principal advantages of the DCF appraisal method, the Net Present Value (NPV) criterion is therefore used throughout this study.

#### **Size and type of cogeneration/heating network**

It is convenient to divide cogeneration/heating networks schemes into various size classes<sup>2</sup>, TABLE 7.7.

1. Uncertainty about the presence or scale of benefits and costs though may be unrelated to time. A premium to the discount rate for risk is often widely recommended.
2. See Andrews, D.C and Lowe, R.J, 1983, 'The economics and relevance of medium, small and micro combined heat and power/district heating' for example.

**TABLE 7.7 - Classification of cogeneration/heating network schemes by heat load and suitable plant**

Plant	Large 200 Mwt	Medium 30-200 Mwt	Small 1-30 Mwt	Micro 10kwt-1Mwt
Steam turbine	-----			
Spark ignition gas engine				-----
Diesel		-----		
Fuel cells				-----
Combined cycle	-----			

In the distributed, very small island, high population density (Guernsey) context the 'Small' and possibly 'Medium' cogeneration/heating network classifications<sup>1</sup> are the most appropriate.

In terms of suitable plant, steam turbines and combined cycle plant are essentially large-scale. Whereas diesels can provide modular, small-scale, high efficiency, local cogeneration for very small distributed clusters (possibly replaced by the Fuel Cell in the long-run if the technology becomes commercially available, see Chapter 8).

The primary advantage of small-scale cogeneration over

1. Concentrations of population (ie. high population densities) are well suited to hot water piped from a local power station to private and public buildings, for space and water heating purposes. This is not new technology, but its application on the U.K. mainland has been rare. On very small islands unusual.

A parish heating network based upon circulating hot water (from cogeneration plant/supplementary boiler) can be implemented without significant changes to domestic plumbing etc.

electricity-only combined cycle plant is its higher effective efficiency<sup>1</sup>. Even though electricity-only combined cycle is another 'energy efficient' route it is one which offers an 'all electric' future<sup>2</sup>.

The most important step in planning a cogeneration proposal involves the determination of plant capacity and operating options; the possibilities for sizing are:-

- (1) Peak electrical demand.
- (2) Minimum (or baseload) electrical demand.
- (3) Peak thermal demand.
- (4) Minimum (or baseload) thermal demand.
- (5) Maximum NPV.

On the U.K. mainland individual cogeneration projects are seldom sized to meet a peak electrical demand. An appropriately sized plant might be sized somewhat larger than baseload to achieve minimum payback through increased electrical savings. The plant size being determined by a

1. At present, capital costs of the two technologies seem very similar.

2. The term 'combined cycle' usually means a gas turbine with waste heat recovery used to produce additional electrical power via boilers and a steam turbine. The main difference in comparison with diesel engines (as shown in Section 7.1) is they are not as efficient.

The trend is not toward an all-electric society; the high investments from generation to end-use that would have to accompany the use of electricity in other than its most appropriate sectors of demand cancel out such a trend.

combination of energy demand levels and financial analysis in favour of 'optimum' rather than 'maximum' cash flows.

The method we use for sizing cogeneration plant and for estimating annual performance in the present work is based upon a simplified, but sufficiently accurate energy analysis. Where we focus on (1), (2) and (5) above; each proposal sized to be capable of meeting peak electrical demand.

The viability of a correctly-sized cogeneration installation depends on a real requirement for the heat and power generated. If either of these cannot be used productively or sold beneficially (or if either could be purchased at a lower cost) then this could result in a net 'loss' of value to the system proposed.

An energy analysis<sup>1</sup> combined with a financial analysis must therefore be used to select the size of cogeneration plant. Cogeneration should only be run when it provides a true financial benefit, but we need to ask at what level of energy service delivery does this apply ?

Each level of energy service delivery needs to be compared on the basis of the present value total system costs over a period equal to the anticipated life of equivalent (centralised) electricity generation. The anticipated life cycle is usually related to the number

1. Our energy analysis uses the measured QOT demand profiles detailed in Appendix C; annual MD and electricity consumption data from the SEB and annual heat consumption for each site.

of hours run; for a diesel engine a life cycle of 80,000 hours is used, over a study period of ten years.

More than one medium-speed diesel in an installation (with several smaller units operating in parallel) provide increased reliability and fuel consumption performance through lower part-load (75%) operation<sup>1</sup> if they are sized correctly; this is what we should be aiming to achieve.

The selection of (2) from the entry screen of the Guernsey energy model (Parish clusters) displays a sub-menu from which a parish can be selected, and it is within this modelling environment that the various levels of energy service delivery can now be simulated.

#### **7.6 Energy service delivery**

##### **Level 1 delivery - individual sites**

For investment appraisal purposes the services of a wholly owned subsidiary of Midlands Electricity plc (Cogeneration Systems Limited, Worcester) was used to provide the required cogeneration capital and operational cost data. Budget prices relate to cogeneration plant (but do not include waste and supplementary heat boilers) with electrical outputs ranging from 48 to 14000 kW are provided in APPENDIX H (1992 prices).

Each cogeneration unit is capable of running on Gas Oil, LPG or Methane; budget installation costs include:-

1. See Madsen, A.E, 1989, 'Optimising today's generator controls and planning for the future', where specific fuel consumption against diesel engine loading is shown in diagrammatic form.

- (1) Delivery to the site.
- (2) Installation on the site.
- (3) Connection to the fuel supply system<sup>1</sup>.
- (4) Cabling and switchgear for cogeneration isolation.
- (5) The provision of acoustic enclosures.

The management effort required for installing such cogeneration plant has recently been reduced by the emergence of companies offering turnkey (build, operate and maintain) packages (eg. Cogeneration Systems Limited<sup>2</sup>).

The budgeting for Level 1 delivery in the Forest deals with a cogeneration proposal for each of the abstraction sites (States Airport, Sovereign Flowers and Mallard Country Club). APPENDIX I provides the QOT data, along with current energy costs (1992), for the three sites. The demand for heat is based upon accounts for monthly fuel delivery to the sites.

Figure 87 provides the discounted cashflow for energy used at the three sites over a ten year period (1993-2002), with no real adjustment in electricity or heat price per annum; TABLE 7.8 provides the present value (with a discount rate of 15%).

1. Distributed oil storage tanks provided 'free' by the successful oil supply agency.
2. Budget operational costs used in the present work include for the remote monitoring and operation of the plant under a 'total maintenance programme', which covers all maintenance activities, to ensure a guaranteed availability of 90% over a ten year period.



THE PARISH OF FOREST

DISCOUNTED CASHFLOW (Based on current usages; constant money prices)  
 Electricity price adjustment 1.0000 Annual real increase assumed in market price  
 Heat price adjustment 1.0000

Site	1992	1993	1994	1995	1996	1997	1998	1999	2000	2001	2002
States Airport:											
Electricity cost	-135,341	-135,341	-135,341	-135,341	-135,341	-135,341	-135,341	-135,341	-135,341	-135,341	-135,341
Heat cost	-14,783	-14,783	-14,783	-14,783	-14,783	-14,783	-14,783	-14,783	-14,783	-14,783	-14,783
Ann.cashflow	-150,124	-150,124	-150,124	-150,124	-150,124	-150,124	-150,124	-150,124	-150,124	-150,124	-150,124
D.cashflow	-130,543	-113,515	-98,709	-85,834	-74,638	-64,903	-56,437	-49,076	-42,675	-37,10	
Sovereign Flowers:											
Electricity cost	-38,714	-38,714	-38,714	-38,714	-38,714	-38,714	-38,714	-38,714	-38,714	-38,714	-38,714
Heat cost	-40,370	-40,370	-40,370	-40,370	-40,370	-40,370	-40,370	-40,370	-40,370	-40,370	-40,370
Ann.cashflow	-79,084	-79,084	-79,084	-79,084	-79,084	-79,084	-79,084	-79,084	-79,084	-79,084	-79,084
D.cashflow	-68,769	-59,799	-51,999	-45,216	-39,319	-34,190	-29,731	-25,853	-22,481	-19,54	
Mallard Country Club:											
Electricity cost	-18,217	-18,217	-18,217	-18,217	-18,217	-18,217	-18,217	-18,217	-18,217	-18,217	-18,217
Heat cost	-5,588	-5,588	-5,588	-5,588	-5,588	-5,588	-5,588	-5,588	-5,588	-5,588	-5,588
Ann.cashflow	-23,805	-23,805	-23,805	-23,805	-23,805	-23,805	-23,805	-23,805	-23,805	-23,805	-23,805
D.cashflow	-20,700	-18,000	-15,652	-13,611	-11,835	-10,292	-8,949	-7,782	-6,767	-5,88	
D.factor	1.0000	.8696	.7561	.6575	.5718	.4972	.4323	.3759	.3269	.2843	.2472

TOTAL DISCOUNTED CASHFLOW

States Airport	£	-753,437	Discounted cashflow for energy
Sovereign Flowers	£	-396,904	used at the three (Forest)
Mallard Country Club	£	-119,472	abstraction sites over a ten
			year period

**TABLE 7.8 - Present value of energy used at the three (Forest) sites over a ten year period**

States Airport	-	£753,437
Sovereign Flowers	-	£396,904
Mallard Country Club	-	£119,472

The diurnal electrical load duration curve for the Airport produced a maximum electrical demand of 240 kWe on the working day the profile was measured (22-23 Nov 1990). In contrast, maximum electrical demand recorded by the SEB during the year reached 456 kWe. From annual electricity consumption, the minimum (or baseload) demand is estimated to be 167 kWe.

From this data and an examination of the diurnal profile we can size cogeneration plant and estimate performance. Two cogeneration units are selected for the Airport, one 220 kWe for baseload at 75% load (165 kWe) and one 385 kWe for peak demand purposes (75% - 289 kWe).

Figure 88 provides the energy analysis and Figure '89 the financial analysis for the Airport site.

#### **Energy analysis**

The first section of the energy analysis details the hours run and load prediction; generated kWh matches the States Airport annual electricity consumption (neglecting losses). The cogenerated thermal energy is estimated to be 2,696 MWh; some 1,052 MWh could be used by the Airport and 1,644 MWh is surplus to requirements and dumped.

THE PARISH OF FOREST  
 HOURS RUN AND LOAD PREDICTION  
 States Airport - 1 \* 220 kWe & 1 \* 385 kWe engines

LEVEL 1	1993	1994	1995	1996	1997	1998	1999	2000	2001	2002
Hours run (90% Av)	7,884	7,884	7,884	7,884	7,884	7,884	7,884	7,884	7,884	7,884
0.220 MW (Base load)	.1670	.1670	.1670	.1670	.1670	.1670	.1670	.1670	.1670	.1670
Hours run	1,347	1,347	1,347	1,347	1,347	1,347	1,347	1,347	1,347	1,347
0.385 MW	.2890	.2890	.2890	.2890	.2890	.2890	.2890	.2890	.2890	.2890
MkWe generated	1,706	1,706	1,706	1,706	1,706	1,706	1,706	1,706	1,706	1,706
MkWh generated (220 kWe)	2,047	2,047	2,047	2,047	2,047	2,047	2,047	2,047	2,047	2,047
MkWh generated (385 kWe)	648	648	648	648	648	648	648	648	648	648
Annual MkWe generated	1,706	1,706	1,706	1,706	1,706	1,706	1,706	1,706	1,706	1,706
Annual MkWh generated	2,696	2,696	2,696	2,696	2,696	2,696	2,696	2,696	2,696	2,696

ENERGY CONSUMPTION

	1993	1994	1995	1996	1997	1998	1999	2000	2001	2002
G.O. Litres	458,332	458,332	458,332	458,332	458,332	458,332	458,332	458,332	458,332	458,332
Other fuel										
Total Gas Oil used	458,370	458,370	458,370	458,370	458,370	458,370	458,370	458,370	458,370	458,370
Total - Other fuel										

TOTAL ENERGY COST PREDICTION

	1993	1994	1995	1996	1997	1998	1999	2000	2001	2002
Fuel price adjustment	1.0000									
Starting price of G.Oil	.1490	.1490	.1490	.1490	.1490	.1490	.1490	.1490	.1490	.1490
Cost of Gas Oil used	68,297	68,297	68,297	68,297	68,297	68,297	68,297	68,297	68,297	68,297
Price - other										
Cost of other										
Total Fuel Cost	68,297	68,297	68,297	68,297	68,297	68,297	68,297	68,297	68,297	68,297

Figure 88

THE PARISH OF FOREST

DISCOUNTED CASHFLOW

Electricity price adjustment 1.0000  
 Heat price adjustment 1.0000  
 Electricity unit price .0937 £/kWh (1992)  
 Heat unit price .0185 £/kWh (1992)  
 O & M cost .0098 £/kWh (1992)

LEVEL 1	1992	1993	1994	1995	1996	1997	1998	1999	2000	2001	2002
Energy cost	-68,297	-68,297	-68,297	-68,297	-68,297	-68,297	-68,297	-68,297	-68,297	-68,297	-68,297
Operational & M cost	-16,718	-16,718	-16,718	-16,718	-16,718	-16,718	-16,718	-16,718	-16,718	-16,718	-16,718
Capital repayment	-30,144	-30,144	-30,144	-30,144	-30,144	-30,144	-30,144	-30,144	-30,144	-30,144	-30,144
Electricity revenue	159,844	159,844	159,844	159,844	159,844	159,844	159,844	159,844	159,844	159,844	159,844
Heat revenue	49,867	49,867	49,867	49,867	49,867	49,867	49,867	49,867	49,867	49,867	49,867
Ann.cashflow	-301,440	94,552	94,552	94,552	94,552	94,552	94,552	94,552	94,552	94,552	94,552
D.factor	1.0000	.8696	.7561	.6575	.5718	.4972	.4323	.3759	.3269	.2843	.2472
D.cashflow	-301,440	82,219	71,495	62,169	54,060	47,009	40,877	35,546	30,909	26,878	23,372
NET PRESENT VALUE (£'000)			173.0938								

Total capital cost (1992):  
 £ 301440.0000  
 220 kWh CHP: £85340  
 Installation: £20000  
 385 kWh CHP: £166100  
 Installation: £30000

Financial analysis for the  
 Airport site

Figure 89

The ratio of maximum seasonal heat to minimum seasonal power = 120 MWht/120 MWhe = 1:1 (see APPENDIX I). The heat to power ratio of the proposed commercially available cogeneration plant is 1.555:1 (220 kWe) and 1.665:1 (385 kWe), see APPENDIX H.

The second section of the energy analysis details the energy conversion efficiency of the proposal. In general, the present study uses a heat/power ratio of 1.4 with an electricity conversion efficiency of 35% (see Sections 9.1 and 11.5). With small variations due to the availability of commercial cogeneration plant (approximate fuel conversion equivalents are provided in APPENDIX A).

The third and last section of the energy analysis provides an energy cost prediction which we can now use in a financial analysis.

#### Financial analysis

The financial analysis provides a discounted cashflow for the proposal, with the following criteria:-

(1) Electricity and heat unit costs are taken from TABLE 4.9 - 9.37p/kWhe and 1.85p/kWht<sup>1</sup>.

(2) Delivered fuel price (Gas Oil) is taken from TABLE 4.7 as 14.9p/litre (but sensitivity analysis on fuel price is provided later in Chapter 11).

(3) Real fuel price adjustment per annum - 0

1. Using 1.48p/kWh prime fuel (see TABLE 4.9); the cost of heat generated 1.85p/kWht (using a boiler efficiency of 80%).

- (4) Real electricity price adjustment per annum - 0
- (5) Real heat price adjustment per annum - 0
- (6) Discount rate - 15% (but sensitivity analysis on discount rate is provided later in Chapter 11).
- (7) Operational cost - 0.98p/kWhe<sup>1</sup> (no real price adj).
- (8) Environmental cost<sup>2</sup>

If all heat energy is sold on the Airport site the NPV is + £173,094, which may offer a better investment when compared with the sunk cost of - £753,437 over the same ten year period. However, all the heat energy cannot be used at the Airport, over half would have to be dumped.

Our analysis does not assume importation of electrical energy from the SEB. The evaluation of the potential of distributed cogeneration needs to test the extent that each level of energy service delivery might be capable of meeting

1. Budget operational costs (which cover all operational and maintenance activities) are provided by Cogeneration Systems Limited, Worcester (1992 prices).
2. In principle, 'costs' should include a monetary allowance to reflect the burden to society of the emitted pollutants. The pollution 'cost' would be either the cost of prevention or a rather more intangible sum reflecting environmental damage, if prevention were not possible (or simply too costly).

We will show that cogeneration is 'cleaner' and therefore does not require environmental justification. We therefore do not include an environmental cost.

peak electrical demand independently<sup>1</sup>.

The financial analysis for all three level 1 sites is now provided in TABLE 7.9.

**TABLE 7.9 - Financial analysis for level 1 delivery**

	Sunk costs	NPV (If all heat sold)
	£	£
States Airport <sup>2</sup>	- 753,437	+ 173,094
Sovereign Flowers <sup>3</sup>	- 396,904	+ 140,096
Mallard Country C. <sup>4</sup>	- 119,472	- 41,414

The reality of energy service delivery at each individual site results in the production of reject heat at two of the sites and a heat energy requirement at the third.

#### **Level 2 delivery - Parish abstraction**

The budgeting for level 2 delivery in the parish of Forest deals with a single cogeneration proposal. Just summing the maximum electrical demands for each site to size this level 2 proposal will result in too high a value, because the electrical loads do not peak at the same time.

1. The decision as to whether any energy service company should be private or public may be important in relation to company taxation. The SEB pays no tax consequently no tax payable has been included in our cash flow analysis.
2. Selected cogeneration plant - 1 \* 220 kW & 1 \* 385 kW (69% of heat energy has to be dumped).
3. Selected cogeneration plant - 1 \* 48 kW & 1 \* 70 kW (165% more heat energy is required)
4. Selected cogeneration plant - 1 \* 48 kW & 1 \* 70 kW (11% of heat energy has to be dumped)

It is necessary therefore to derate each individual site so that the summation of the individual loads equal the simultaneous maximum demand of the group of three sites. This 'maximum load integration and smoothing' process is likely to produce capital equipment savings.

This can be achieved by applying a 'Coincidence Factor', which is defined as "the ratio of the maximum coincident total demand of a group of energy end-users to the sum of the maximum demands of individual end-users comprising the group". The Coincidence Factor is the reciprocal of the Diversity Factor, see APPENDIX J.

Using the measured load profiles and annual SEB maximum demand data for each site produces a coincidence factor of 0.66 and a diversity factor of 1.515. Simultaneous maximum electricity demand is estimated to be 417 kWe and baseload 278 kWe. Seasonal electrical and heat energy profiles for the group are provided in Figures 90 and 91 respectively.

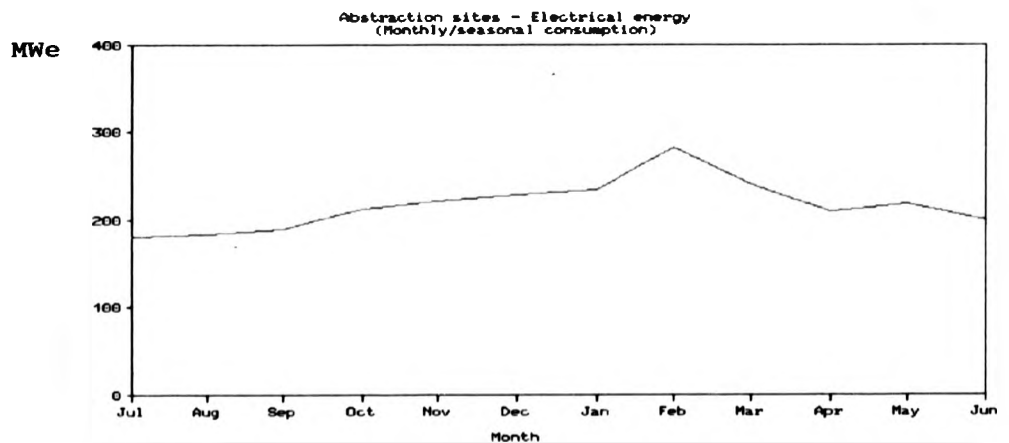

Figure 90



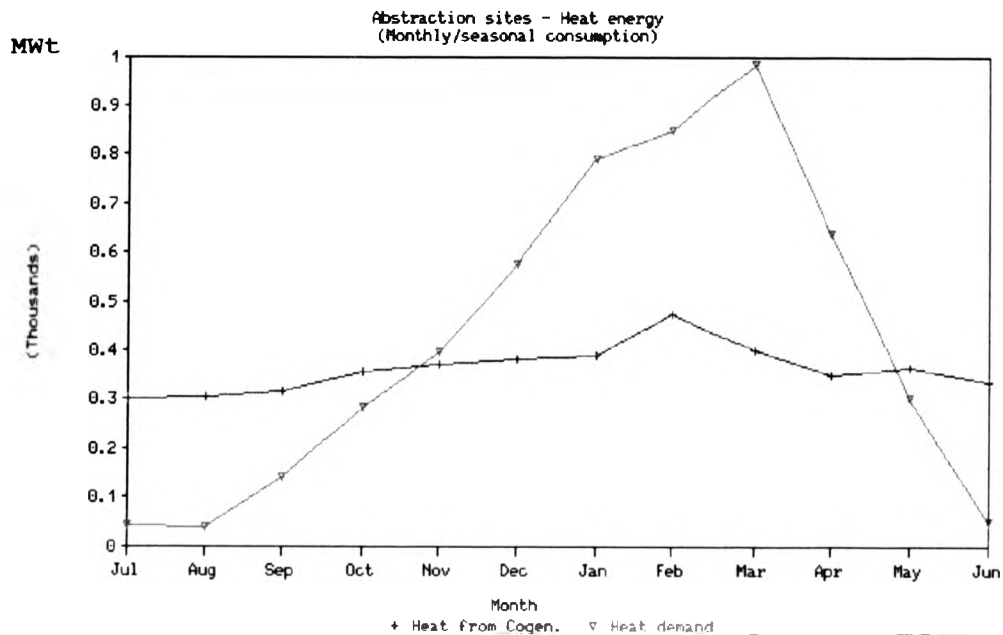

Figure 91

There is a requirement now to distribute electricity and also heat from the source/sources located at the States Airport to the other two sites (see Figure 86). The distance between the Airport and the Mallard Country Club is 800 m; from the main road to Sovereign Flowers is 150 m (heat distribution network costs are discussed in Chapter 11).

If the heat from cogeneration is now superimposed on the seasonal heat requirement of the three site group (see Figure 91). This indicates the need for a supplementary heat boiler, in order to provide supplementary heating between the months of November and May.

The financial analysis for level 2 delivery is provided in TABLE 7.10.

TABLE 7.10 - Financial analysis for level 2 delivery

	Sunk costs	NPV (If all heat sold)
	£	£
Abstraction sites <sup>1</sup>	- 1,269,813	+ 539,503

The annual primary fuel imported into the Island for heating these three sites is:-

- (1) 136,715 litres of Gas Oil
- (2) 367,000 litres of Product 469

Assuming an 80% boiler conversion efficiency, the required end-user heat energy requirement at the three sites is 4,271.5 MWht.

The annual electrical energy requirement for the three sites is 2,604.7 MWhe, which represents approximate annual primary fuel imports for electricity alone of some 575,000 litres.

In contrast, to meet level 2 energy service delivery 700,000 litres of Gas Oil has to be imported into the Island. Which would generate 2,605 MWhe of electrical energy and 4,120 MWht of heat energy (30% of the latter being dumped). 111,752 litres of Product 469 is still required to fuel the supplementary boiler between November and May.

Neglecting heat and electricity distribution losses, which should be very small when considering how close the

1. Selected cogeneration plant - 1 \* 385 kW<sub>e</sub> & 1 \* 150 kW<sub>e</sub>  
(30% of heat energy has to be dumped)

three sites are to each other. This suggests a 24.8% reduction in petroleum product imports into the Island, in this particular case.

Level 2 delivery in the Forest thus displaces over half the high sulphur content Product 469 and all Heavy Fuel Oil imports normally used by centralised electricity production, with consequent reductions in greenhouse gases.

This is where the benefits of a distributed approach to energy planning begin to become persuasive. Further shifts of the coincidence factor, through local management, may also achieve further marginal benefits.

#### Level 3 delivery - total production demand

As outlined simplistically in STEP2 of the QQT demand model (see Section 7.5) the diurnal profile for production electricity demand in the Forest is formed as follows:-

(1) The Mallard Country Club measured profile (31-1 June 91) is factored to the highest electrical MD recorded by the SEB (\* 1.7). Which is again factored (\* 3.1) to simulate the remaining tourism sector demand (see TABLE 7.2).

(2) This is repeated for Sovereign Flowers for the vinery sector (\* 4.5 & \* 1.71) and the States Airport for the commercial/public buildings sector (\* 1.9 & \* 1.55).

(3) The three demand profiles produced are then added and the resulting profile multiplied by the coincidence factor of 0.66, Figure 92.

## Estimated diurnal production electricity demand for Forest

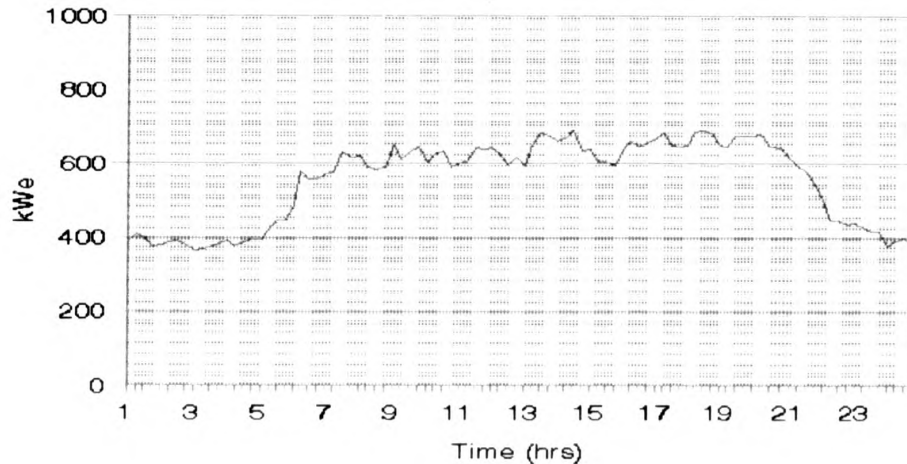

Figure 92

This curve can again be used to size cogeneration plant; peak electrical demand of 620 kWe and minimum (or baseload) demand of 320 kWe<sup>1</sup>.

The financial analysis, using the same criteria (all heat units sold) produces a NPV of + £1,132,496. Level 3 heat distribution costs would now be somewhat higher than level 2 delivery because of the total number of energy end-users (14 tourism, 68 vineries and 64 commercial/public buildings).

In considering production electricity demand for Forest it is also useful to compare the ratio of production/domestic electricity consumption within each of the

1. Selected cogeneration plant - 2 \* 385 kWe

parishes, TABLE 7.11.

**TABLE 7.11 - Parish production/domestic electricity consumption ratio**

Vale	0.66
St.Sampsons	0.96
Castel	0.51
St.Saviour	0.70
St.Peter/Torteval	0.51
Forest	1.77
St.Andrew	1.14
St.Martin	0.89
St.Peter Port	1.76

Only three parishes have a larger non-domestic electricity consumption (Forest, St.Andrews and St.Peter Port), which may have an important influence on energy planning and again highlights geographic importance. Planning on an aggregate Island wide basis may not optimise these diverse parish energy characteristics.

#### **Level 4 delivery - total domestic demand**

Cogeneration is becoming widely used in commercial/tourism/industrial installations on the U.K. mainland. As yet, there has been little penetration into possibly the largest market, domestic heating.

A cogeneration unit whose thermal output is used primarily for space heating is in a favourable position. Its highest outputs would tend to coincide very closely with the highest demands for electricity. Because of the very close correlation between space heating requirements and the seasonal pattern of electricity demand and may be particularly relevant to Guernsey, with large domestic

consumption in nearly all parishes<sup>1</sup>.

As outlined in STEP 3 of the QQT demand model (see Section 7.5) the profile for domestic demand is formed as follows:-

(1) The band 1 small user requirement is 18 times the band 1 profile, see APPENDIX G.

(2) Similarly, the band 2 profile is multiplied by 396 and band 3 profile by 73.

(3) The diurnal domestic load duration curve is then derived by adding the three band profiles together. Peak electrical demand is 650 kWe and minimum (or baseload) demand 120 kWe<sup>2</sup>, Figure 93.

**Estimated diurnal domestic electricity demand for Forest**

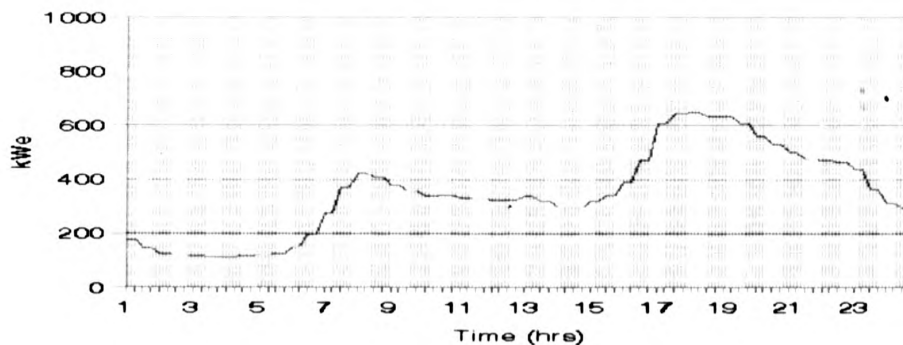

**Figure 93**

1. In 1815 (in the case of Forest) there were 443 people living in 97 houses. By 1951 there were 1,133 people and 301 houses. By 1992 the number of dwellings had risen to 487 and the population to 1,386.

2. Selected cogeneration plant - 1 \* 150 kWe & 2 \* 385 kWe

The financial analysis, using the same criteria, produces a NPV of + £233,753 if all heat units are sold.

Level 4 energy service delivery serves 487 domestic end-users, but ALL are located in a densely populated area (4.2 km<sup>2</sup>).

#### Level 5 delivery - interactions with neighbouring clusters

Other neighbouring clusters may exist within each parish which may take four forms:-

(1) Single domestic energy service - The prospects of finding a reliable small engine for a single house micro-CHP is dependent upon the development of a motor able to run for at least 10,000 hours without maintenance, and silent<sup>1</sup>.

(2) Domestic end-user cluster - It is a sobering thought that a small truck engine is sufficient to heat and light a 50 house estate<sup>2</sup>. Although stationary engines for micro-CHP are more robustly constructed than automotive engines, the whole unit including generator is only 2 metres long and can be wheeled into place on a trolley by two men. The unit located in a small plant room together with control system and hot water storage, with the output shared between houses. Noise abatement though is a serious concern and acoustic enclosures need to be included.

The heat is distributed by insulated distribution

1. The most distinctive characteristic of household energy consumption is its enormous variability. This is an extreme case of disaggregation where smoothing is completely lost.

2. See Dooley, T, 1991, 'Pocket-size power packs potential' for example.

heating pipes and fed into conventional wet radiator heating installations in each house. Regardless the 3 phase 415 V electricity produced by such means only meets part of the electrical load (extra electricity needs to be supplied from the grid) and this does not meet our criteria that each energy service delivery must be capable of meeting simultaneous maximum electrical demand.

A criticism of domestic cogeneration is that house heat loads (especially in low energy houses) are too small to make it worthwhile. Simply the parish of Forest (and also the other parishes) do not have such large housing estates.

(3) Production end-user cluster - The aggregate electrical demand profile of the three site abstraction is not smoothed by adding the three individual profiles together. Production demand in the Forest is dominated by the States Airport, and so is the aggregated electrical demand profile; but this may not be the case in other parishes.

(4) Combined production/domestic end-user cluster - The parish of Forest itself (4.2 km<sup>2</sup>) is a small combined cluster of 487 domestic end-users and 146 production end-users. Other parishes may possibly lend themselves to separate (distinct) clusters but this is certainly not apparent in the Forest.

**Level 6 delivery - the parish energy service company idea**

By distributed cogeneration we mean that in the long-run Guernsey's centralised power and energy base will not exist. Island energy requirements will be met by energy



service companies (ESCOs) operating cogeneration plant (supported by renewable energy resources where appropriate) within each cluster and parish<sup>1</sup>.

The requirement here is for level 6 delivery to be self-sufficient and, for the purposes of our analysis, to consider that the importation of electrical energy from the States Electricity Board is simply not available.

Electrical analysis (see Chapter 10) indicates that the existing Island electricity distribution network is more than capable of sustaining distributed power and energy services from parish based cogeneration plant. An important advantage of this approach (compared to centralised power production) will be shown to be a significant reduction in energy losses because the output from the cogenerator is consumed close to the supply source. Also, if parish electricity demand grows, savings can also be made on capital expenditure that would otherwise be necessary to expand the capacity of the centralised Island electricity network.

All the present assumptions on Guernsey have favoured a centralised electricity organisation, dependent upon an implicit bias in favour of large, slow-speed, two-stroke diesel power generation at one site.

1. We are not simply considering in the present work the integration of cogeneration plant into the Island electricity system, but proposing that parish based, distributed cogeneration plant 'becomes' the Island electricity system, and more.

Obsession with size (based upon a concept of economies of scale) though may not necessarily be valid. Plant size does not always equate with efficiency because of the 'peakiness' of load. The large diesel engines presently located at the one site at Vale can result in technical inflexibility and lack of responsiveness to changing demand patterns. In contrast, diversification of risk into smaller, parish based plants (built with much shorter lead times) is a way of increasing flexibility of response and spreading risk. We will go on to show that significant energy savings can be achieved with distributed cogeneration, which will reduce electricity transmission/distribution losses and also power generation losses at peak (see Chapter 10).

To ensure adequate security of electricity supply extra centralised generation capacity (known as the planning margin) has to be provided to ensure 100% availability, to cover all eventualities. If capacity is provided by a number of smaller distributed units this will be shown to reduce the planning margin significantly.

The lack of responsiveness to changing centralised demand patterns can result in adverse duty cycles for the large slow-speed diesel engines at the Vale power station. Up and running for 18 hours of a typical working day and then sometimes stopped due to insufficient night load (ie. the duty cycle is incompatible with large engine size). Which results in the heating up and cooling down of engines, with thermal stresses occurring and the cracking of piston crowns.

The States Airport is the energy 'hub' of the parish of Forest and this is where the level 6 delivery energy service company (ESCO) should probably be based.

The electrical load duration curve for level 3 (total production demand) can now be added to the load duration curve for level 4 (total domestic demand) to derive the final parish (Forest) model, Figure 94. Cogeneration plant can then again be selected to meet and match this profile.

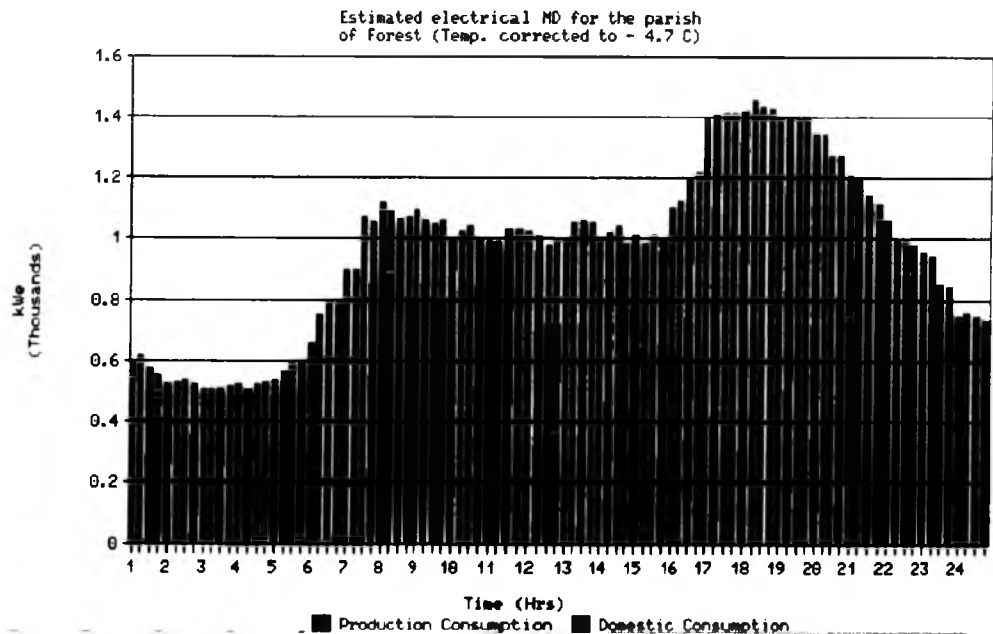

Figure 94

As mentioned earlier, where distinct loads exist for much of the day it is more energy efficient to operate with an engine (or engines) at 75% full load, rather than using a large engine at part load for much of its life. Bearing this

in mind we can select plant to meet the peak electrical demand of 1.5 MWe and minimum (or baseload) demand of 550 kWe<sup>1</sup>. The financial analysis, using the same criteria, produces a NPV of + £1,312,092.

Each level of energy service delivery has been modelled on the basis of all available heat energy being sold, in order to compare the different levels of delivery on the same basis (*ceteris paribus*, E demand and E supply), Figure 95. However, a comparison on this basis is unrealistic since 30% of heat energy is still dumped at level 3.

It appears that only when there is a mix of production and domestic heat end-user demands that 'customer use of waste heat' may be maximised and a true financial benefit achieved. Simply the amount of domestic heat load that will be required needs to be tested locally. We will show that location specific energy imbalances are important and need to be considered carefully (see Chapter 9).

It is at the distributed (parish) level of energy service delivery that different mixes of production and domestic consumption occur and where our attention is now focussed.

1. Selected cogeneration plant - 1 \* 750 kWe (baseload), 1 \* 750 kWe (intermediate) and 1 \* 385 kWe (peak).

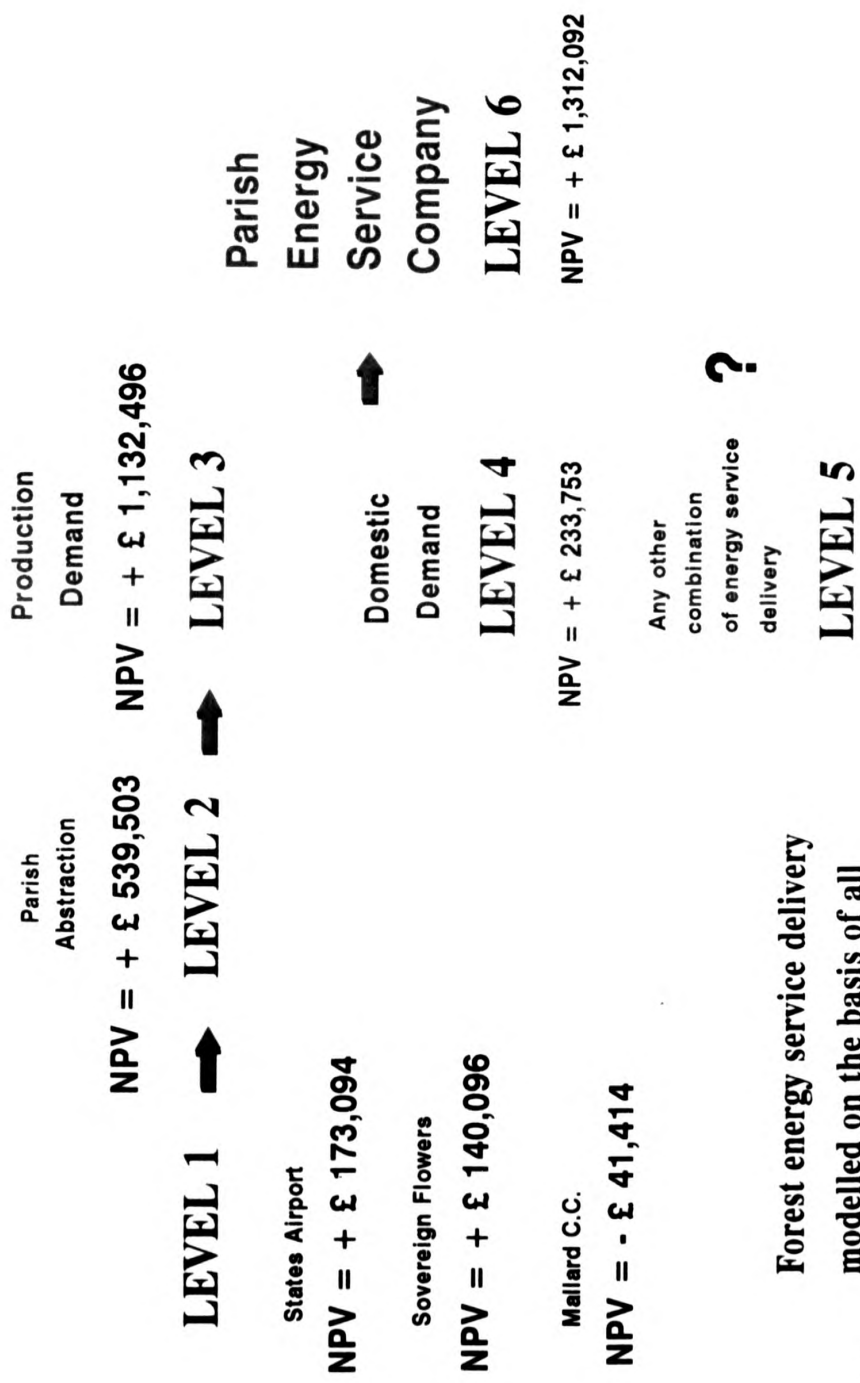

Forest energy service delivery modelled on the basis of all available heat energy sold (ceteris paribus E demand and E supply)

Figure 95

### 7.7 Validation of results

There are intellectual doubts about the extent to which an energy model can act as a surrogate for the real world. Some attractively simple models can conceal an immense unarticulated network of assumptions, judgements and understandings in terms of which they must be interpreted. Actual site measured values are used in the present work in an attempt to increase reliability.

Each of the final parish energy models are intricately linked to the data set used in each model's development. The data modelled relates to actual (measured) electrical demand profiles for each of the four economic sectors within the production classification, in all the Guernsey parishes. For domestic demand we have used good quality, banded, domestic electrical demand profiles from load research conducted by the U.K. Electricity Association.

The modelling process described for the Forest has also been followed to produce the final profiles for the remaining eight parishes, and these are provided in APPENDIX K.

The highest Island peak electricity demand to date occurred on 7 February 1991 with a very low daily mean temperature of - 4.7 C (+ 23.54 F). For all nine final parish models we have therefore attempted to temperature correct to - 4.7 C. We have done this by using winter day time temperature responses for each economic sector from data again kindly provided by the U.K. Electricity

Association. For domestic demand, for every one degree fall in temperature a 1% increase in electricity demand has been used.

For production demand, for every one degree fall in temperature 0.7% (Comm); 0.7% (Tourism); 0.5% (Ind) and 1% (Vineries) increase in electricity demand has been used.

To assess the credibility of this ratio estimator approach, the nine temperature corrected final parish demand profiles were added and compared with the highest Island peak electricity demand profile of the 7 February 1991, Figure 96.

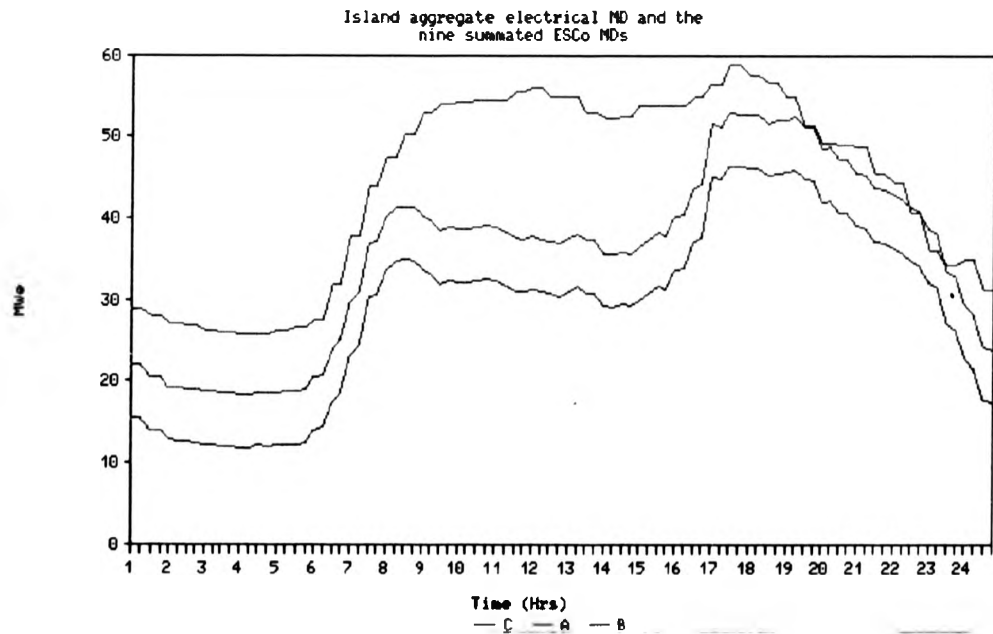

Figure 96

- A. 7 February 1991 electrical M.D. = 58.8 MWe
- B. Summated nine Parish electrical M.D. = 47.3 MWe
- C. Profile 'B' plus 6.5 MWe demand loss at peak

The difference in peak demand is 11.5 MWe, but in Chapter 10 we will demonstrate that 6.5 MWe of this is the demand loss at peak due to centralised electricity production (ie. the generation plant required at the present centralised power station site purely to supply peak demand losses).

The nine final (parish) QQT demand profiles compare well with the 7 February 1991 highest Island electricity demand profile and explain over 90% of true peak demand.

Clearly, the resultant temperature corrected parish quality<sup>1</sup> (Q), quantity (Q) and timing (T) profiles are not the same; each model is location specific.

The new focus on energy planning is not now at the aggregate Island level, which has been the norm, but the distributed level of the Guernsey parishes. We now go on to discuss this new focus by operating the 'Energy Planning' sub-system model on paper in Chapters 8, 9, 10 and 11. .

#### **SUMMARY**

- (1) The Guernsey energy model tests the priority of obtaining power from distributed cogeneration (with other possible sources treated as secondary).
- (2) For a thorough (QQT) approach it is essential to obtain

1. Quantity and Timing are well served by the discussion in this Chapter. Quality is less obviously subjected to any 'matching' criteria but this will be addressed in Chapters 8 and 9.



a set of reliable large end-user energy profiles, even though it is very time consuming.

(3) The technique of using a ratio estimator, with annual consumption as the auxiliary variable (for meta modelling/ scenario evaluations), appears to be valid.

(4) Locally, the possibilities for integrating the requirement for electrical energy with the requirement for heat energy become much clearer.

(5) An energy analysis combined with a financial analysis must be used to select the size of cogeneration plant for economical optimality.

(6) Obsession with size (based upon a concept of economies of scale for centralised power generation) may not necessarily be valid.

(7) It appears that only when there is a mix of production and domestic heat end-user demands that 'customer use of waste heat' may be maximised and a true financial benefit achieved. Location specific energy imbalances are therefore important and need to be considered carefully.

It is at the distributed (parish) level of energy service delivery that different mixes of production and domestic demand occur and where our attention is now focussed.

(8) The historical decision to implement 'central' power stations has in part been because electricity loads

(individual QQT profiles) do not rise and fall in unison. The loads on central power stations are likely to be much less sharply peaked than those in individual disaggregated areas.

The present work suggests that this is not (such) a dominant influence in the Guernsey clusters.

## CHAPTER 8

### THE BEHAVIOUR OF THE SYSTEM

The traditional approach to energy planning, which is practised on many small islands (including Guernsey), is central supply orientated. The approach is from the top downwards; it starts from extrapolations of historic demand trends<sup>1</sup> and then planning goes on to focus on the feasibility of (and resource requirements for) adding to centralised energy supplies.

These planning methods are just not appropriate for distributed cogeneration. A thorough (QOT modelling) approach is required of which the 'Energy Planning' sub-system model operated on paper in Chapters 8, 9, 10 and 11 is now the subject.

This Chapter leads to the conclusion that to optimise fuel inputs, local (parish) energy service companies (ESCOs) may be needed to provide (local) energy services; now marketing heat energy as well as electricity.

#### 8.1 Inappropriate planning methods

The present approach on Guernsey, with little or no States of Guernsey intervention in the energy market, has lead to:-

- 1) Coal imports being reduced from 67% of primary energy imports (ex.transport) in 1960 to 14% in 1990 (see Chapter

1. See Ewbank Preece Limited, 1989, 'Review of generation development' on Guernsey for example.

4).

2) The expansion of electricity use for low temperature purposes (such as space heating and water heating), in spite of low overall thermal efficiency (see Chapter 5).

3) The so-called waste heat being dispersed in clouds of steam over the centralised power station and Bridge shopping area in the Vale.

4) Little or no expenditure on fuel saving equipment, such as insulation and waste heat recovery; on energy from refuse, sewage, wind, sunshine etc.

5) The development of the horticultural industry based upon cheap oil, and then its subsequent collapse (see Chapter 2).

6) The high cost of energy in the Island in comparison with other island situations; Jersey for example (see Chapter 4).

7) The need to increase central power station chimney heights to 57m to disperse emissions because of local protestations.

There are a number of defects associated with this traditional approach:-

(1) The inability to cater properly for cogeneration.

(2) The absence of the effects of planning other fuel sectors on electricity planning.

(3) The failure to forecast energy trends accurately.

(4) Over planting in the context of central power generation.

(5) The almost complete exclusion of end-user reactions from the planning process.

(6) Wrong generation plant mixes, sizes, types and flexibility based upon sub-optimal criteria.

(7) The divorce of long-term planning from ownership.

An earlier review by Ewbank Preece<sup>1</sup> (1985) mentions that:

"It is thus necessary to consider the possible usage of heat rejected in generation as part of the review of the SEB's future energy policy .....

We have therefore concluded that, while sales of low grade heat could be an interesting issue if an overall energy policy for Guernsey were established, the SEB plans for electricity generation and supply will not be influenced by the possible utilisation of low grade heat rejected from generation".

Is this a confused statement or someone or somebody making a choice ?

Any proposed change to the system must be based upon using less to produce more, both to conserve resources (energy, capital, manpower) and reduce waste. This prospect is central to our modelling (and one interesting issue which

1. Ewbank Preece Limited, May 1985, 'A brief review of the SEB's future energy policy options'.

the present work attempts to address).

#### **A new distributed energy planning approach**

There is a need to change the traditional focus away from 'prepared' fuels and electricity towards the energy services that people actually want, such as comfort, illumination, cooked food, mobility.

To optimise fuel inputs, it may be necessary to establish local energy service companies (ESCOs) to provide (local) energy services that market heat energy as well as electricity. Parish based ESCOs, not only to distribute and provide parish energy needs but also, perhaps, to invest in demand side energy efficiency improvements as a part of a contractual package. Present centralised suppliers on the Island do not regard energy saving as either a demand reducing tool or as a possible business venture.

The ESCO operation could be developed as a tripartite partnership between the SOGEMS, ESCo and energy end-user, and backed up in the SOGEMS/ESCO and ESCo/end-user cases by legal contracts (see ESCo accountability, Section 10.2). The ESCo would offer its expertise and possibly sources of finance to deliver specifically agreed results, with contracts specifying who pays what and what is deliverable.

An island which also relies entirely on imported energy cannot fail to give some consideration to the possible contribution from renewable sources. Nevertheless a local ESCo cannot depend on weather patterns (this would involve too great a risk for the end-users) because electricity

needs have to be met all the time. Demand must be met in the most unfavourable weather conditions (eg. no wind or thick cloud cover) therefore fossil fuels must be used to secure energy services, at least in the short to medium term.

Important is that energy supplied by alternative sources create parallel savings in fossil fuel imports. Which might further reduce the Island's dependence on world fuel markets (and on non-renewable polluting resources) and should not be ignored, but this should not be based on wishful thinking.

We will show that renewable sources can make a contribution, possibly greater in some parishes than others (see Chapter 9). Yet this is not to say that in the long-run renewable energy sources may not be able to supply an increasing proportion of Island energy requirements, but this will depend on changed consumer preferences/needs.

A pragmatic view (and one we adopt in the present work) is that the first objective of decentralisation should be the reduction of petroleum product imports into the Island. Our new focus on parish energy service provision then allows us to consider possible (local) renewable energy contributions, within local (parish) based decision making<sup>1</sup>.

Our new distributed energy planning procedure:-

(1) Obtains a set of reliable large end-user QQT energy

1. Involved in decision making with respect to, for example, the proportion of wind turbine generators permitted within the parish etc.

profiles (see Chapter 6).

(2) Uses computer models (see Chapter 7).

(3) Adopts meta modelling/scenario evaluations rather than centralised deterministic planning (see Chapter 7).

(4) Changes the emphasis from the provision of fuels to the provision of comfort, mobility etc (see Chapter 8).

(5) Provides a degree of flexibility, which allows for alternative energy source options (see Chapter 9).

(6) Includes end-user behaviour and participation fully within the planning process (see Chapter 10).

(7) Considers the economics (see Chapter 11).

(8) Treats energy decisions from a wider systems perspective (see Chapter 12).

## **8.2 Energy availability**

### **Alternative fossil fuels:**

The choice of primary fuel depends on such factors as proximity, availability and relative cost, for example:-

#### **(1) Electricity cable link with France**

In terms of proximity, the SEB and the States of Guernsey have already considered at length the option of an electricity cable link with France. While at present it is thought unattractive on cost grounds, it has not been discarded; however there are sound reasons for rejecting this option:-



(a) The installation of such a cable would represent a very large capital investment<sup>1</sup> in relation to the size of the SEB and hence a serious step to take.

(b) Guernsey is technically a foreign country to France.

(c) The cable or cables would land on a beach immediately to the north of Vale castle, and then to the centralised power station site in the Vale. Which would further perpetuate the current centralised approach to electricity provision on the Island<sup>2</sup>.

(d) Many schemes employing submarine power cables have suffered poor availability due to cable faults.

(e) Important is that diesel based power generation plant would still be required to meet Guernsey's electricity demand anyway (1) because the French EDF tariff in the winter is too prohibitive and (2) to supply the Island should the submarine cable link fail.

(f) French electricity is primarily derived from nuclear sources<sup>3</sup>; indications are that EDF themselves are considering diversification away from nuclear energy, as their forecasts predict that within five years they will

1. £50 million for a 50 MWe link (1992 prices).

2. Jersey currently has a cable link with the French mainland; a link between Jersey and Guernsey is considered to be of similar cost as one with France, but there may be an element of inter-island politics also at work here.

3. See Guernsey Evening Press, 2 August 1985, 'Nuclear industry like a cancer on this earth'.

have absorbed all their surplus power<sup>1</sup>.

## (2) Gas pipeline link with France

The option of a natural gas pipeline to France has also been considered (natural gas may have better reserves than oil and a more stable price).

Dual-fired oil/natural gas power stations have already been built in Eire (and elsewhere) but these are of the gas turbine type as opposed to diesel engines<sup>2</sup>.

A techno-economic study<sup>3</sup> on behalf of the Guernsey Gas Company concluded that the economies of such a pipeline would be:

"quite tight and that 'aggressive' marketing would be essential in gaining substantial new markets for natural gas".

## (3) Coal

Coal resources worldwide are abundant, but solid fuels are harder to transport and handle and require significant areas for storage<sup>4</sup>. Also Coal scores badly on environmental grounds.

1. See *New Scientist*, 12 January 1991, 'EDF considering diversification away from nuclear energy'.
2. See *Guernsey Evening Press*, 26 March 1990, 'French natural gas link comes closer'.
3. See *British Gas*, January 1990, 'Techno-economic feasibility study for Gas Energy (CI) Limited - Phase Two Report'.
4. All of which are problematic in relation to very small island communities.

#### (4) Cogeneration

One of the advantages of the distributed cogeneration concept is the freedom in the choice of basic fuels; oil, LPG, methane and Island refuse. This range of usable fuels may form the foundation of a reliable energy supply.

#### Renewable energy sources:

Renewable energy is an opportunity to provide at least some of the energy needs of each parish but (as we will show in Chapter 9) opportunities for exploiting renewable energy sources are limited to a large extent by parish geography and natural endowment.

The U.K.'s Department of Energy have defined three categories of renewable energy<sup>1</sup>:-

##### (1) Economically attractive:

Biofuels<sup>2</sup> - combustion of dry wastes -

Mass burn incineration does not have a reputation for clean reliable operation, but this is inconsistent with experience elsewhere. The States of Jersey Resources Recovery Board for example, operate an incinerator on the island of Jersey to dispose of refuse, and supply power to their electricity network. We will show that mass burn incineration may also be appropriate within the St.Sampson's cluster.

1. See Department of Energy (U.K.), 1988, 'Energy paper No.55' and also Bevan, B.G, 1990, 'Renewable energy technologies for power generation in the United Kingdom - an overview'.

2. Biofuels - often termed biomass.

### Biofuels - landfill gas -

Utilising landfill gas for power generation provides a safe and effective way of disposing of the methane produced in the waste degradation process, which is a potential hazard in landfills<sup>1</sup>. We will show that this may well be appropriate in the Vale cluster.

Similarly, the use of the Island's sewage, using the well established process of anaerobic digestion, may be appropriate in the St.Peter Port cluster.

Some aspects of passive solar design of buildings -  
Which is a demand side measure.

### (2) Promising but uncertain:

#### Land based wind energy

In order to examine 'real-life' land based wind energy on Guernsey (and observe turbine behaviour) we later use a probabilistic simulation, which incorporates random phenomena.

#### Tidal energy

No suitable land-locked area, with the possible exceptions of Grande Havre or Rocquaine Bay, exist on the Island. Costs would be excessive and would encounter major environmental objections<sup>2</sup>.

1. See Guernsey Evening Press, 13 March 1993, 'BOA want to burn tip gas'. Board of Administration want to build a £200,000 gas abstraction plant to get rid of methane from the Bordeaux tip.

2. See Fielden, D, 21 April 1993, 'Visit report to the Le Rance Barrage near St.Malo'. Internal SEB report.

### Shoreline wave energy

This would require a vast area of sea to be sterilised from other activities (ie. fishing, sub-sea movements etc)<sup>1</sup>; no practical engineering has yet been identified.

### Geothermal hot dry rocks

No known faults appear in this area of the English Channel.

### Wind energy offshore

The first offshore windfarm, owned and built by the Danish utility Elkraft Power Company Limited, was commissioned in 1991 and consists of eleven 450 kWe wind turbines<sup>2</sup>.

The total investment was approximately twice as much as it would have been for a windfarm of the same size on land, with the expected energy production approximately 60% higher. This higher energy production offshore is modelled in the Guernsey context later in Chapter 9.

### Energy forestry

Guernsey has a relatively small proportion of afforested land, much of the undergrowth and woods were

1. See Guernsey Evening Press, 30 April 1988, 'Islands well suited to provide wave power electricity' or

Cave, P.R. and Evans, E.M, 1986, 'Tidal stream energy: Economics, technology and costs' or

Pingree, R.D and Maddock, L, 1977, 'Tidal residuals in the English Channel'.

2. See Jespersen, K.D, October 1991, 'First offshore windfarm starts up'.

destroyed by occupation forces during the second world war, and by development<sup>1</sup>.

**Small scale, low head hydropower**

The Island is too small to develop any substantial rivers. Good flow and head are required to create an efficient hydro system and no parish has either.

**(3) Long shots:**

Large scale offshore wave energy

Active solar heating

Geothermal aquifers

Photovoltaics

**Areas where new technology could be applied:**

Within the 'Micro' cogeneration plant category (see TABLE 7.7) is the promising future use of the Fuel Cell, which may be an appropriate (local) modular technology for small distributed clusters.

The development of the Fuel Cell, which converts fuel into electricity without combustion (and hence with very low emissions) is progressing steadily<sup>2</sup>. Such ongoing technological advance suggests that its potential in the future may be an alternative technology to the diesel engine, but this is in the long-run.

1. There is now no land area available for re-afforestation.

2. See Energy Economist, October 1991, 'World status: Fuel Cells'.

### 8.3 Poor demand side energy efficiency

On Guernsey conservation was practised through history until the second half of the twentieth century<sup>1</sup>, ships timbers were preserved to build houses/barns and organic wastes were spread over the land as fertiliser. A primitive form of space heating was to keep cows and pigs within the traditional Guernsey cottage for example.

There was a time when almost every possible resource available in each parish was exploited, either for mechanical or thermal energy. Windmills were erected to supplement existing water mills due to the scarcity of seasonal water. Traditional houses were characterised by 'terpis' (large open fireplaces burning gorse), 'buzzets' (cakes of dried cow dung), dried peat and vraic and waste wood.

Certainly ever since 1965 (when GNP data started to be collected) economic growth has been impressive (see Chapter 2). Such increases in wealth are a significant factor in the growth of energy consumption on the Island, particularly electricity (see Figures 38 and 43, Chapter 5).

Ward<sup>2</sup>, in her Forward to Lovin's book 'Soft Energy Paths', stresses the potentially disastrous consequences of wealth. Which creates new habits and expectations that are accompanied by an irrational lack of care about usefulness

1. See Schumacher, D, 1985, 'Energy: Crisis or opportunity' for a general discussion on historical energy conservation.

2. Ward, B, 4 March 1977, Foreword to 'Soft energy paths'.

or waste. The process develops habits in individual people, institutions and whole societies, which accustom them to operating on the basis of excess and wastefulness (which is sometimes referred to as the high consumer discount rate problem).

This has already been seen to be a problem on the Island, where the Board of Administration have concentrated on providing information as a rather passive method of influencing these market forces. They launched a brief energy conservation campaign in 1990 and produced a booklet entitled 'A Guide to Home Energy Costs and Savings', delivered by newsagents to all Island homes<sup>1</sup>.

In contrast, the centralised energy suppliers (SEB, Gas Energy, BFL, Oil companies) seem concerned only with the supply of their prepared fuels and devote little attention to the efficiency of their use. A change from this traditional situation to more local energy services would contribute to overcoming these barriers.

The local energy service company idea is far more than a passive consumer information programme. It addresses the four criteria that must be satisfied to capture the full economic potential (supply and demand side) for energy conservation:-

(1) It deals with the high consumer discount rate problem.

1. See Board of Administration, October 1990, 'A guide to home energy costs and savings' and 'Handy hints to help you save energy'.



- (2) It can be profitable for the companies involved.
- (3) It can avoid penalising non-participants.
- (4) It can ensure that estimated energy savings are close to actual.

**The prospects for improved demand side energy efficiency on Guernsey**

**Domestic energy efficiency:**

Domestic buildings play a vital role in energy efficiency because the building stock is more permanent and consumes the largest proportion of Guernsey's annual imports of primary energy (see Figure 34, Chapter 5). The U.K. Energy Efficiency Office suggest that 82% of total domestic energy use is typically related to space and water heating<sup>1</sup>.

So many domestic buildings on the Island have dormer windows that you have the feeling that many of the population must be living in the roof space. Probably one house in three is dormered, with the result that this has now become an accepted Guernsey pattern (with dormers probably a fairly late arrival on the housing scene<sup>2</sup>). The older double storey houses of the 17th and 18th centuries normally used oak, elm or ship's timbers in a pattern of roof construction with internal bracing, which effectively precluded using the roof space as a room (to this day, most

1. U.K. Energy Efficiency Office, 1984, 'Energy use in the domestic sector by typical end-use'.

2. Guernsey Evening Press, 24 April 1984, 'Change from thatch to tile made dormers worthwhile'.

of the older large houses are still dormer-less). Some though, were reroofed completely during the change from thatch to tile and putting in dormers then became worthwhile and possible.

Over 50% of domestic properties on the Island have between 4 and 5 rooms (from census data), we therefore surveyed a typical Guernsey detached cottage with typical (dormer) attic bedrooms (living room, dining room, kitchen, bedroom 1, bedroom 2 and bathroom) with associated lobby, hall and landing. The property, which was visited by the Writer and floor areas measured, is in the parish of St.Sampsons and shown in Figure 97.



Typical Guernsey cottage

Figure 97

The heat losses of the individual rooms were calculated using U.K. Energy Efficiency Office (EEO) 'U' values, and are provided in TABLE 8.1.

**TABLE 8.1 - Calculated heat losses of individual rooms of a typical Guernsey home**

Room	Floor area (m <sup>2</sup> )	Heat loss (Wt)
Living	14.00	1341
Dining	10.24	1258
Kitchen	7.00	1154
Bathroom	5.44	715
Bedroom 1	14.00	1061
Bedroom 2	10.24	990
	-----	-----
Total	60.92	6519

(The heat loss = 107 Wt/m<sup>2</sup> floor area)

The EEO classify domestic dwelling heat losses as follows:-

- Good** - 50 Wt/m<sup>2</sup> floor area and less
- Medium** - 50-80 Wt/m<sup>2</sup> floor area
- Poor** - Above 80 Wt/m<sup>2</sup>

The energy losses of a typical Guernsey home are therefore poor; the losses associated with each individual room are provided in TABLE 8.2.

**TABLE 8.2 - Energy losses of individual rooms of a typical Guernsey home (Wt)**

Room	Liv.R.	Din.	Kit.	Bath	Bed1	Bed2	Total
Ext.Wall	504	524	407	311	532	478	2756
Window F.	323	323	198	198	323	323	1688
Part.Walls	223	198	174	-	-	-	595
Infiltration	159	116	215	82	126	126	824
Floor	132	97	88	68	-	-	385
Tile roof	-	-	-	-	80	63	143
Asphalt roof	-	-	72	56	-	-	128
	-----	-----	-----	-----	-----	-----	-----
Total	1341	1258	1154	715	1061	990	6519

The greatest proportion of heat loss (42%) is through the solid external walls of the house<sup>1</sup>. 26% is lost through the single glazed window frames. 13% through infiltration. 9% through partition walls (plastered both sides). 6% through the solid floor with wool carpet and felt overlay. 2% through the main roof (which in this case has tiles on battens and felt ceiling overlaid with 150 mm glasswool). 6.5kWh, some three quarters of the heat energy purchased by the household in the form of oil, gas, coal or electricity, quickly escaping.

Even though there have been recent improvements in Guernsey's building regulations for new constructions (see Section 6.4) their effect will be heavily lagged. The principal route for influencing the pace of change in the housing stock (to achieve greater energy efficiency) must be by retrofitting the existing stock, not by new build. Given the low annual demolition and replacement rates, a high proportion of dwellings likely to be inhabited in 2020 are already constructed.

After space and water heating, the remaining 18% of domestic energy use relates to cooking (8.6%), appliances

1. It is often suggested that not a lot can be done about insulating solid granite walls, where there is no cavity to fill.

Consideration though should be given to the French method of internal insulation using about 100 mm of 'rockwool' insulation behind an inner skin of 50 mm brickwork. Externally added insulation is also possible. For a reference see Milbank, N.O and Southern, J.R, 1981, 'Improving the thermal insulation of solid walled buildings in the United Kingdom' for example.

(7.8%) and lighting (1.6%). All of which are mainly electricity end-uses and their efficiency influences consumption. Which is all determined by the size and structure of the appliance stock and the way it is used, the level of end-user's income, fuel price and the transitory effect of the weather. Overall a complex picture, but in the present work we are interested primarily in the scope for efficiency improvements.

As mentioned earlier, a comprehensive assessment would require the examination of all specific end-uses on Guernsey (and the efficiency of the technologies presently employed) but this is not altogether necessary for our requirements. Assessments carried out by Marshall and also McInnes et al<sup>1</sup> suggest that there is potential for economically justifiable efficiency improvements in all end-uses, with the largest economic saving potential to be found in lighting applications.

It is estimated (Ibid) that savings in the range of 10-20% could result from overall efficiency improvements in cooking/appliances/lighting, in the domestic sector. The full achievement of this potential however, implies the replacement of existing appliances and this could only really happen over about two decades.

1. Marshall, M.R, April 1991, 'End-use analysis of domestic electricity sales' and

McInnes, G and Unterwurzacher, E, 1991, 'Electricity end-use efficiency'.

Regardless, targeting demand-side energy efficiency measures in the domestic sector principally upon the domestic building stock may produce the greatest energy savings.

**Commercial/tourism/industrial energy efficiency:**

In order to assess the energy efficiency potential within each of these sectors we make use of the performance yardsticks based upon Normalised Performance Indicators (NPIs), determined by the U.K. Audit Commission (1985)<sup>1</sup>.

**Commercial/public buildings**

Space and water heating typically represents 82% (public building) and 68% (commercial building) of total energy use (U.K. Energy Efficiency Office).

The use of the States Electricity Board's Geographic Information System (GIS) of the Island was of great help in determining the necessary floor areas for each large end-user site (in each abstraction) in order to derive energy consumption estimates.

TABLE 8.3 compares these energy consumption estimates derived by the Writer, with typical NPI ratings for these large end-user sites.

1. A problem with the use of yardstick values is that they are calculated by summing the energy consumption from all of the fuels used in a building (including electricity).

Nevertheless, it is possible to obtain a measure of the energy performance of the abstraction sites by comparison with NPIs published for most common types of buildings.

TABLE 8.3 - Energy consumption and NPI ratings for the comm/public bldg in each parish abstraction

	NPI target kWh/m <sup>2</sup>	Consumption estimates kWh/m <sup>2</sup>	Saving %
Vale - Alliance C & C	N/A	203	-
St.Sampsons - Prison	550	462	0
Castel - King Edward VII Hosp.	605	1534	61
St.Saviours - Mont Variouf Sch.	250	832	70
St.Peter/Tort - Le Riche Stores	N/A	393	-
Forest - Airport	400	538	26
St.Andrews - Grammar Sch.	250	367	32
St.Martins - P.Eliz. Hosp	605	830	27
St.Peter Port - Leisure Centre	570	660	14
			---
			Avg 33%

The Prison appears to be within yardstick, with no energy savings identified using this form of analysis; but from the site survey, savings can be identified. A possible reason for this may be that the NPI Yardsticks have been created from sample buildings which include old and new structures, well run and poorly run buildings.

Likewise, some adjustment to the figures for the King Edward VII Hospital may also be necessary; the targets set out in EEO publications exclude laundries for example. A more detailed approach may be possible using the information provided by others (the U.K. Department of Health for example), but this is left to other researchers.

#### Tourism

Space and water heating typically represents 69% of total energy use (U.K. Energy Efficiency Office).

TABLE 8.4 again compares the energy consumption estimates derived by the Writer, with typical NPI ratings

for the major tourism end-user, in each parish abstraction.

**TABLE 8.4 - Energy consumption and NPI ratings for the major tourism end-user in each parish abstraction**

	NPI target kWh/m <sup>2</sup>	Consumption estimates kWh/m <sup>2</sup>	Saving %
Vale - Peninsula Hotel	410	548	25
St.Sampsons - None	N/A	N/A	-
Castel - Hougue du Pommier H.	410	1114	63
St.Saviours - Atlantique Hotel	410	772	47
St.Peter/Tort - Imperial Hotel	410	431	5
Forest - Mallard Country Club	410	405	0
St.Andrews - None	N/A	N/A	-
St.Martins - St.Margarets Lodge	410	1128	64
St.Peter Port - St.Pierre Park	410	1290	68
			---
			Avg 39%

#### Industrial

There are no NPI Yardsticks produced for the industrial end-users on the Island, TABLE 8.5. The first four use electrical energy solely for motive power<sup>1</sup>.

**TABLE 8.5 - Energy consumption for the major industrial end-user in each parish abstraction**

	NPI target kWh/m <sup>2</sup>	Consumption estimates kWh/m <sup>2</sup>	Saving %
Vale - Juas Quarry	N/A	E	-
St.Sampsons - Les Vardes Quarry	N/A	E	-
Castel - K. Mills Water pumping	N/A	E	-
St.Saviours - Reservoir	N/A	E	-
St.Peter/Tort - None	-	-	-
Forest - None	-	-	-
St.Andrews - Dairy	N/A	5069	-
St.Martins - None	-	-	-
St.P.Port - Intersurgical Ltd	N/A	667	-

1. Guidance notes for reducing energy consumption of electric motor and drive systems are provided in the EBO 'Good practice guide 2' - Energy saving opportunity 20%.



The dairy industry typically use some 84% of total energy for process/space/water heating purposes (U.K. Energy Efficiency Office). From estimates of average and best practice (Ibid), the energy saving potential of the dairy on Guernsey may be greater than 30%.

The industrial energy end-user in the St.Peter Port abstraction primarily uses electricity for injection moulding purposes (and manufactures surgical appliances).

**Horticulture/vinery energy efficiency:**

Over 90% of total energy consumption in this sector is used for space heating; less than 10% for electricity end-uses (pumping, high pressure sodium lighting and refrigeration).

There are no NPI Yardsticks produced for horticulture/vinery end-users, TABLE 8.6.

**TABLE 8.6 - Energy consumption for the major horticulture/vinery end-user in each parish abstraction**

	NPI target kWh/m <sup>2</sup>	Consumption estimates kWh/m <sup>2</sup>	Saving %
Vale - (Vingtaine)	N/A	721	-
St.Sampsons - (Kenilworth)	N/A	658	-
Castel - None	-	-	-
St.Saviours - (Les Mourants)	N/A	264	-
St.Peter/Tort - (Bader Roses)	N/A	884	-
Forest - (Sovereign Flowers)	N/A	929	-
St.Andrews - (J.Angenent Roses)	N/A	245	-
St.Martins - (Bali-Hai)	N/A	349	-
St.P.Port - (Ramee Roses)	N/A	304	-

Early growing is very dependent upon favourable light conditions, but structures which allow the highest possible

light penetration also allow the highest energy losses.

Demand-side insulation measures can be applied throughout the 24 hour day/night cycle or at night only. The first method produces the greatest energy saving<sup>1</sup> (40%), and can be further increased if additional insulation is applied at night. The second method allows better light conditions during the day, but less energy saving (29%).

**Transport energy efficiency:**

Road transport consumes 22% of the Island's total primary fuel imports, air transport 3% and water transport 3% (see Figure 31, Chapter 5). Private cars take up around 87% of road transport fuel.

Car ownership is high and continues to grow; over the period 1984-90 motor spirit demand increased by 27.5%, with a close correlation between motor spirit demand and GNP (see Figure 50, Chapter 5).

The highest rate of car ownership worldwide is that of the United States, which had 552 cars for every 1000 people in 1986; car ownership on Guernsey 468 (1986); on the UK mainland 331 (1986)<sup>2</sup>.

The Island Traffic Committee have indicated that Guernsey's remarkable rise in car ownership is now

1. Horticultural Committee, 1992, personal communication.

2. See Energy Economist, 1990, 'When is enough, really enough?'

approaching saturation level<sup>1</sup>, but this may not be strictly correct. Saturation level is generally assumed to occur when 90% of the driving age group of 17-74 years own a car (100% car ownership being unlikely because some people will be prevented or deterred by disabilities or other factors). On this basis, saturation level was exceeded in 1986.

With future GNP growth there could still be a further increase in motor spirit imports into the Island, which would further contribute to the greater degradation of the environment. The increased pollution by traffic not only affecting air quality through the discharge of oxides of nitrogen and hydrocarbons, but also contributing to global warming (particularly through the generation of carbon dioxide).

In contrast, the widespread use of Electric Vehicles (EVs) on the Island (as part of our distributed cogeneration ethos) would alleviate this problem, as well as aid in smoothing ESCo electricity demand curves.

Electricity generation is far more efficient when demand is consistent and the fact that recharging would take place at night, plus the fact that peak transport demand is generally in the summer, would mean that parish based generating plant could operate consistently at 75% of full load.

1. Island Traffic Committee, August 1991, 'An integrated transport and planning strategy for Guernsey'.

Electric drive vehicles have become of increased interest recently because of the new legal requirement in California from 1998 onwards, for 2% of all vehicles sold to be 'zero-emission vehicles' (growing to 10% by 2003)<sup>1</sup>. The advent of the zero-emission regulatory action in California has forced the automotive industry to take the electric vehicle seriously; EVs are the only practical way of meeting this zero-emission requirement.

Even though the pure electric vehicle has had limited range and extended recharge time, their use on very small islands (such as Guernsey) may be viable<sup>2</sup>. Particularly so when it is part of an overall strategic energy planning approach, as advocated here.

Macpherson<sup>3</sup> for example, considered the application of traffic compatible EVs on the very small islands of Lewis and Harris. Data was collected on the driving patterns and attitudes of island motorists, which may well be transferable to the present work.

The aim of his research was to study the performance of EVs and the extent to which they could replace Internal Combustion Engines (ICEs). He concluded that a significant

1. See Keboe, L and Griffiths, J, October 1990, 'California adopts tough pollution laws'.
2. On an Island where the maximum speed limit is 35 mph and cars rarely journey more than 30 miles per day, electric vehicles have clear advantages.
3. Macpherson, C.J, 1989, 'Electric road vehicles for island communities' - PhD thesis, University of Stirling.

proportion of the transportation function on the islands could be undertaken by EVs. The results showed that the EV could climb any gradient on the islands and could achieve an operating range of around 50 to 60 miles (similarly in urban driving conditions). 37% of island cars were found not to be 'inconvenienced' by the range limitation; but if the vehicle range was doubled, over 80% of ICE cars would fall within the application potential. The major, and only real barrier to EV introduction on the islands was their limited range and the economic case surrounding their introduction.

Over the last few years this limitation of range of EVs has been improving and the efficiency of electric drive vehicles markedly improved. The General Motors 'Impact' vehicle for example has an efficiency of over 90%, almost three times that of electric vehicles in 1980<sup>1</sup>. Important is a comparison of the ICE and EV in terms of their 'overall' energy efficiency, TABLES 8.7 and 8.8.

**TABLE 8.7 - ICE energy efficiency**

Primary crude at refinery	3 kWh
Motor spirit consumed in car	2.55 kWh
ICE efficiency	25%
Energy to wheels	0.64 kWh
Overall efficiency	21%

1. See Moore, T, April 1991, 'New ! Clean ! Electric !' and also

International Energy Agency, 1993, 'Electric Vehicles: Technology, Performance and Potential'.

Using motor spirit imports into the Island for 1990 (366 GW, see Figure 31), the overall efficiency is shown in annual import terms below.

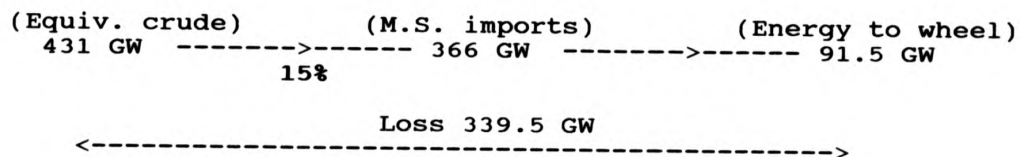

**ICE Overall efficiency**

**TABLE 8.8 - EV energy efficiency**

Primary crude at refinery	3 kWh
Gas oil consumed at P.Station	2.79 kWh (35% eff)
End-user energy into battery	0.98 kWh
EV efficiency	90%
Energy to wheels	0.88 kWh
<b>Overall efficiency</b>	<b>29%</b>

Based upon the same energy to wheels, the overall efficiency for the EV scenario is again shown in annual energy import terms below.

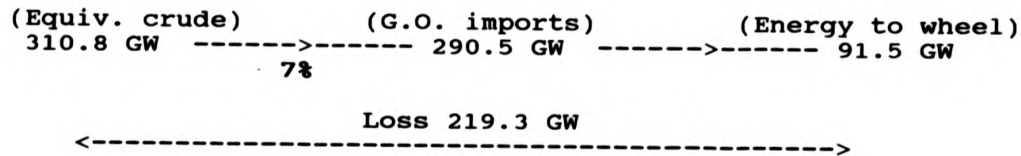

**EV Overall efficiency**

The all EV scenario has five advantages:-

(1) With distributed cogeneration (85% efficiency), it may be possible to recover 145 GWT of heat energy and reduce the overall energy loss from 219.3 to 74.3 GW, increasing overall efficiency to 76%.

(2) The change from motor spirit to gas oil (a less refined petroleum product) results in an accompanying reduction of 75.5 GW in prime fuel imports.

(3) A 27.9% reduction in non-renewable fossil fuel used at the refinery.

(4) It may also have an important 'peak smoothing' effect (see Chapter 9).

(5) Lower noise pollution and zero-emissions.

In 1992 (in preliminary work) Brown et al<sup>1</sup> considered the introduction of EVs into each parish; the Writer directing the research effort and supervising the field work, locally. The results of this work, and the impact of the 'peak smoothing' effect of EV charging on parish electricity demand profiles, are again discussed in Chapter 9.

1. Brown, P, Fielden, D and Jacques, J.K, 1992, 'Electric vehicles: An alternative transportation system for Guernsey'. University of Stirling internal report.

#### 8.4 Mismatching of energy QUALITY

##### Matching and end-use application in the domestic sector:

The demand for energy in the domestic sector is related to the five energy services domestic end-users presently require: space heating, water heating, cooking, appliances and lighting<sup>1</sup>.

Distributed cogeneration enables a much better matching of energy quality and its end-use application (see Section 6.2). It avoids the wastage presently incurred, where electricity is used for all five purposes (space heating<sup>2</sup>, water heating, cooking, appliances and lighting) in the domestic sector, but what is the size of this mismatching problem ?

There is a need to attempt to quantify the high quality energy presently being used for low quality purposes. A survey on the use of domestic fuels on the Island, which can be helpful in this respect, and we use one that was conducted by 'System Three Scotland' on behalf of the Guernsey Gas Company Limited in 1990<sup>3</sup> and kindly

1. Requirements for all these uses, except water heating, are dependent upon the number of households. The requirement for hot water depends more upon the total number of individuals that are resident in households.
2. Electricity is a uniquely wasteful way of providing heat.
3. System Three Scotland, November 1990, 'Report of a survey on the use of domestic fuels on Guernsey'.

Intended to provide an input to the review undertaken as to the future direction of the advertising strategy for mains gas and bottled gas on the Island.



provided for use in the present work. All interviews were conducted with either the head of the household or his/her spouse, and TABLE 8.9 outlines the demographic profile of the 250 respondents involved.

TABLE 8.9 - Demographic profile of respondents

Sex:	Age:	S. Class:
Male - 36%	Under 35 - 22%	AB - 17%
Female - 64%	35 - 44 - 26%	C1 - 30%
-----	45 - 54 - 18%	C2 - 28%
100%	55+ - 34%	DE - 25%
	-----	-----
	100%	100%

The bias towards females in the sample reflects the likelihood of being at home when contacted by the interviewer. The social class analysis is based on the occupation of the head of household.

As regards the spread of interviews throughout the Island, this was broadly in line with the distribution of population. 80% of interviews were conducted with respondents in four of the parishes; St.Peter Port (28%), Castel (18%), St.Sampsons (17%) and Vale (17%).

Two-thirds of respondents were working, mostly in full-time employment (56%). Just over a fifth (21%) claimed to be retired with 12% describing themselves as housewives, with no paid employment outside home. 2% of respondents said that they were unemployed.

The average household size was just over 2 adults (2.14) and 0.63 children (aged under 15 years). 64% of

respondents claimed to have no children aged under 15 years living in their household.

Around three-quarters of the respondents said that they owned their homes (76%), with the remainder (24%) renting the property.

The average size of property, in terms of rooms was between 4 and 5, with over 50% of properties in these two categories. A significant proportion (26%) were in larger properties of 6 or more rooms with 20% in smaller properties (the majority of flats were in this category).

#### **Space Heating**

Almost 80% of properties had a fireplace (78%) and two-thirds of households had open fireplaces. Coal was the main form of heating used in fireplaces (69%) with wood (6%), electricity (5%) and mains gas (4%) as minority fuels.

Important is that 62% of respondents claimed to have some form of central heating in their homes<sup>1</sup>. Two types of central heating were predominant; oil fired (32%) and mains gas (16%). Solid fuel (6%), coal (4%), electricity (2%) and bottled gas (2%) were the other fuels which accounted for the remainder.

#### **Water Heating**

Just over half the respondents (52%) claimed that their water was heated as an integral part of the central heating

1. Which we will use later in our QOT modelling work, see Chapter 9.

system, with 55% stating that they had a separate means of heating water. Electricity was the main 'separate' fuel for heating water, mentioned by 62% of these respondents. Mains gas (12%) and coal/back boiler (11%) were the other methods of heating water separately mentioned by a number of respondents.

The fact that the sum of these two ways of heating water is greater than 100% reflects a small number of households with water heated as part of the central heating system AND with a separate means of heating water, such as an immersion heater.

Only 3% of households appeared not to have a bath, in comparison to the 61% without a shower. The vast majority of households (84%) had one bath with 12% having two or more. A third of households had a single shower with a further 6% having two or more.

### **Cooking**

The majority of cookers in the respondent's households were electric ones (66%), compared to 25% mains gas and 6% bottled gas. Similarly with ovens 69% were electric, 21% mains gas and 6% bottled gas. Important is that there appears to be some relationship between the use of electric cookers/ovens and age and social class. The older the respondent and the lower the social class, the more likely it appears that the cooker or oven will NOT be electric, and more likely that it will be gas.

### Appliances

Respondents were asked when was the last time that they had purchased a major kitchen appliance. Those aged under 35 years were more likely to have purchased within the last year (45%) compared to the overall average of 34%. Also, there was a correlation between social class and recent purchase; those in the ABC1 social classes were more likely to have done so.

Important also was the different patterns of purchase amongst different age groups:-

(1) Those aged under 35 years were more likely to have bought a fridge/freezer.

(2) Those aged 35-54 were more likely to have bought a microwave or washing machine.

Also, in terms of social class, there were differences in most recent purchase:-

(1) Those in the AB social class were more likely to have bought a microwave, a hob or a dishwasher.

(2) Those in the C1 social class were more likely to have bought a cooker.

(3) Those in the C2 social class were more likely to have bought a washing machine.

All of this provides us with a picture of domestic energy consumption on the Island, and we know from our earlier work that the prime fuel imports to meet these

demands in 1990 was 649 GW (478 GW without overhead, see Figure 36, Chapter 5)). These imports would have been used for the following (typical) end-uses<sup>1</sup>:-

Space heating	- 59.7%
Water heating	- 22.3%
Cooking	- 8.6%
Appliances	- 7.8%
Lighting	- 1.6%
	-----
	100.0%

We can now try to map these prime fuel imports against these end-uses, TABLE 8.10.

TABLE 8.10 - Delivered energy and primary fuel equivalent by end-use (domestic sector - 1990)

	Delivered energy (GW)	Primary fuel equiv. (GW)
Space/water heating	392	445
Cooking	41	87
Appliances	37	97
Lighting	8	20
Total	478	649

(Electricity is used for all appliances and lighting)

From which we can construct a further picture of delivered energy by fuel type for space/water heating end-uses (392 GW), which consists of 135 GW (Coal), 169 GW (Oil)<sup>2</sup> and the remaining 88 GW of 'prepared' fuels, TABLE 8.11.

1. See Energy Efficiency Office (U.K.), 1984, 'Energy use in the domestic sector by typical end-use'.

2. See Figures 30-33, Chapter 5.

**TABLE 8.11 - Delivered energy and primary fuel equivalent for space/water heating (domestic sector, 1990)**

	Delivered energy (GW)	Primary fuel equiv. (GW)
Electricity/Gas	88	141
Oil	169	169
Coal	135	135
	---	---
Total	392	445

A similar construction can also be provided for cooking (41 GW), with fuel type allocated according to the number of electric and gas cooker end-users derived from the 'System Three Scotland' survey, Figure 8.12.

**TABLE 8.12 - Delivered energy and primary fuel equivalent for cooking (domestic sector - 1990)**

	Delivered energy (GW)	Primary fuel equiv. (GW)
Electricity	28	72
Gas	13	15
Oil	-	-
Coal	-	-
	---	---
Total	41	87

Important is that it is the space/water heating end-use that indicates that a low quality end-use (88 GW, TABLE 8.11) is currently being supplied by high quality (electricity/gas) energy forms (141 GW prime fuel equivalent). On the contrary, if the delivered energy was in the form of an oil fired boiler, then the required prime fuel imports would be 110 GW for example. The better

matching of energy quality thus represents a 7% (31 GW) reduction in imports for such purposes.

**Matching and end-use application in the commercial/tourism/ industrial sectors:**

TABLES 8.13, 8.14 and 8.15 provide the delivered energy to each abstraction site.

**Commercial/public buildings**

**TABLE 8.13 - Delivered energy for the major commercial end-user in each parish abstraction - 1990 (GW)**

	Elect.	Gas Oil	Prod. 469	Gas
Alliance C&C (V)	0.7	-	-	-
Prison (St.S)	0.3	1.7	-	0.1
K.Ed.Hosp (C)	0.7	-	6.6	0.2
M.V.Sch (St.Sav)	0.1	0.5	-	-
LR Strs (St.P/T)	0.2	-	-	-
Airport (F)	1.7	0.8	-	-
Gram. Sch (St.A)	1.0	2.7	-	-
PEH (St.M)	1.8	-	8.3	0.3
Beau S. (St.PP)	1.4	-	2.2	-

Gas is used by the two hospitals and the Prison for cooking. Either Gas Oil or the high sulphur Product 469 is used by all end-users for space/water heating (except the two food stores). Electricity is used by all end-users for lighting and appliances (and is used for space/water heating only in the two food stores; mainly in offices).

### Tourism

TABLE 8.14 - Delivered energy for the major tourism end-user in each parish abstraction - 1990 (GW)

	Electricity	Gas Oil	Gas
Peninsula H (V)	0.6	0.5	0.2
None (St.S)	-	-	-
H d Pom. H (C)	0.2	0.5	0.3
Atl. H (St.Sav)	0.2	0.5	0.1
Imp. H (St.P/T)	0.1	0.5	0.1
Mallard CC (F)	0.2	0.4	0.2
None (St.A)	-	-	-
St.M.L. (St.M)	0.3	0.4	0.2
St.P.Pk (St.PP)	1.5	2.2	0.6

Each end-user uses Gas for cooking, Gas Oil for space/water heating and electricity for lighting and appliances.

### Industrial

TABLE 8.15 - Delivered energy for the major industrial end-user in each parish abstraction - 1990 (GW)

	Electricity	Gas Oil	Prod. 469
Juas Q (V)	1.1	-	-
L.Vard. Q (St.S)	1.2	-	-
K.Mills (C)	0.4	-	-
Reserv. (St.Sav)	1.1	-	-
None (St.P/T)	-	-	-
None (F)	-	-	-
Dairy (St.A)	0.6	0.1	2.6
None (St.M)	-	-	-
InterS. (St.PP)	1.0	0.5	-

Only the Dairy has any significant space/water/process heating, and uses the high sulphur Product 469. The prospects for improving the matching of energy quality in each one of these sectors appears to be somewhat less than the domestic sector.



**Matching and end-use application in the horticulture/vinery sector:**

TABLE 8.16 provides the delivered energy to the major end-user within each abstraction.

**TABLE 8.16 - Delivered energy for the major horticulture/vinery end-user in each parish abstraction - 1990 (GW)**

	Elect	Gas Oil	Prod 469	HFO	Coal
Vingtaine (V)	0.3	-	3.7	-	-
Ken. (St.S)	0.4	-	16.3	-	-
None (C)	-	-	-	-	-
L.M. (St.Sav)	0.1	-	-	2.2	-
B.R. (St.P/T)	0.4	-	7.4	-	9.4
Sov.F (F)	0.7	-	3.9	-	-
J.Ang. (St.A)	0.2	-	2.3	-	-
B-Hai (St.M)	0.4	-	1.6	-	-
R.R. (St.PP)	0.3	2.7	-	-	-

This sector has the two largest energy end-users on the Island; Bader Roses in St.Peter/Torteval (17.2 GWh) and Kenilworth vinery in St.Sampsons (16.7 GWh).

Space heating is the most significant end-use, where most major growers use the high sulphur Product 469; electricity is used by all growers for pumping and lighting. The prospects for improved energy quality matching again seem to be poor within this sector.

**8.5 Accounting for the environment**

The western world has started to grapple with the environmental consequences of satisfying its energy needs, Guernsey also has to<sup>1</sup>.

1. The old notion that pollution is the price of progress is becoming discredited.

### **Air pollution levels**

CO2 emissions have the most direct bearing on energy planning. For the contextual background see O'Callaghan<sup>1</sup>, who concludes that there is no alternative but to seek a sustained reduction in the rates of combustion of fossil fuels world-wide via energy management and conservation. Also French<sup>2</sup>, who argues that unacceptably high levels of air pollution around the world suggests that the policies employed to date to combat air pollution have been inadequate.

In terms of energy planning, the rate of CO2 emissions can be reduced by the following measures:-

- (a) By increasing the efficiency of energy utilisation.
- (b) By developing alternative energy sources.
- (c) By absorbing the produced CO2<sup>3</sup>.

Even though numerous technologies are available to reduce emissions, their piecemeal adoption appear not to have led to overall success elsewhere. On Guernsey what is needed is a reorientation of energy and transportation structures, and distributed cogeneration offers just such a reorientation (the increased fuel utilisation of

1. O'Callaghan, P.W, 1993, 'Energy resources, CO2 production and energy conservation'.
2. French, H.F, 1990, 'A global agenda for clean air'.
3. The reduction of CO2 by absorption is in its infancy. The techniques being tested include physical or chemical scrubbing and cryogenic separation.

cogeneration gives it an important role).

EVs for example remove all emissions from vehicles but produce an increased output from the parish ESCo due to the battery charging requirement. However, the reduction of emissions is much easier to control from a point source (using the best available technology) than from numerous, smaller outlets. Important is that the electric vehicle ALSO increases energy efficiency (see Section 8.3).

As a percentage of global pollution, the emissions from the Island are small (a prevailing south-westerly wind direction blow emissions towards France to become global rather than local pollutants). Nevertheless, this does not signify the end to the pollution, as global effects in the long run may affect Guernsey. **The location of origin makes no difference;** integrating environmental maintenance into our 'Energy Planning' sub-system model is therefore essential.

The 'System Three Scotland' survey (see Section 8.4) also addressed the issue of concern for the environment on Guernsey, and found that:-

- (a) 38% claimed to be 'very concerned'.
- (b) 47% said they were 'fairly concerned'.
- (c) 9% stated they were 'neither concerned nor unconcerned'.
- (d) 5% said that they were 'not concerned'.

The sectors of the population more likely to be concerned were:-

- (a) females.
- (b) those aged 35-54 years.
- (c) those in the ABC1 social classes.

Environmental issues are of concern to Islanders and the world scientific community in general appear to believe that global warming is a reality. However, nothing would be wasted by an energy conservation strategy, even if serious global warming did not materialise. For very small island communities it makes good sense to use energy more efficiently and reduce imports (see Chapter 2).

#### The local effects of air pollution

Local effects of pollution are those which occur near or at the source of pollution. A great worry on the Island is the possible consequences of a nuclear catastrophe from the 'Flamanville' installation on the nearby French mainland for example.

On the Island itself, when the large slow-speed diesels were first introduced at the centralised power station in the early 1980s, a switch from Gas Oil to Heavy Fuel Oil was made<sup>1</sup>. This resulted in the area surrounding the power station being showered with carbon deposits and the SEB alleviating the problem by increasing the chimney heights to 57m. Which removed the immediate local problem (without actually decreasing emissions) but continued to add to

1. See Dexter, S.G, 1990, 'Diesel and gas engines and the environment' for a synopsis of specific emissions from diesel engines.

trans-boundary air pollution. Indications are that before the SEB raised the chimney heights the SO<sub>x</sub> level was some 7% above World Health Organisation levels<sup>1</sup>.

The local effects of air pollution caused also by transportation on the Island needs further study, but is not completely necessary for the purposes of the present work.

#### **Environmental legislation**

The major legislation on the U.K. mainland occurred in the 1947 Town and Country Planning Act which, in association with the 1956 Clean Air Act, sought to limit atmospheric discharges (especially those of towns and cities). On Guernsey this has not occurred, and combustion of non-smokeless coal for example is still allowed on the Island.

The Island does not currently legislate against atmospheric discharges (see current legislation, Section 6.4).

#### **Air pollution levels on Guernsey**

In 1991 Black et al<sup>2</sup> considered the air pollution produced by the present energy use on Guernsey (not including transportation); the Writer directing the research

1. Very high concentrations of SO<sub>2</sub> in the atmosphere can damage trees. It is also likely that exposure to high urban SO<sub>2</sub> levels is also the main cause of damage to stonework and roofs, and imposes hidden costs. Further research into the true price of present energy types on the Island (to truly identify these hidden costs) is required.

2. Black, K, Fielden, D and Jacques, J.K, 1991, 'An investigation of the air pollution produced by energy use on Guernsey'. University of Stirling internal report.

effort and supervising the field work, locally.

For each type of emission we ranked each fuel type on a scale from 1 to 7 (7 having the lowest emissions), TABLE 8.17.

**TABLE 8.17 - Guernsey fuel type/emissions ranking**

	CO2	SOx	NOx
Electricity	2	1	1
House Coal	1	4	2
HFO	2	1	3
Product 469	2	1	3
Gas Oil	5	5	5
Kerosene	5	5	5
LPG	7	7	7

In order to estimate Island air pollution levels, the average amounts of kg of pollutants emitted per unit of end-use energy (based upon average U.K. emissions<sup>1</sup>) were used, these are shown in TABLE 8.18.

**TABLE 8.18 - Average amounts of pollutants emitted per unit of end-use energy (U.K. average figures)**

	CO2 (kg/kWh)	SO2 (kg/kWh)	NOx (kg/kWh)
HFO	0.258	0.00323	0.00061
Coal	0.336	0.00369	0.00067
GO	0.245	0.00039	0.00036
LPG	0.231	-	0.00036

Global warming continues to remain the main environmental concern associated with energy use, and most assessments of the impact of energy on the greenhouse effect consider CO2 emissions only. In the present work, as well as

1. See Munday, P.K, 1990, 'U.K. emissions of air pollutants'.

CO<sub>2</sub>, SO<sub>2</sub> and NO<sub>x</sub> emissions for Guernsey (1990) are also estimated, TABLE 8.19.

TABLE 8.19 - Guernsey CO<sub>2</sub>/SO<sub>2</sub>/NO<sub>x</sub> emissions (1990)

	CO <sub>2</sub> (10 <sup>6</sup> *kg)	SO <sub>2</sub> (10 <sup>6</sup> *kg)	NO <sub>x</sub> (10 <sup>6</sup> *kg)
Electricity	144	1.80	0.34
House Coal	63	0.69	0.13
HFO	14	0.18	0.03
Product 469	43	0.54	0.10
Gas Oil	26	0.04	0.04
Kerosene	43	0.07	0.06
LPG	29	-	0.05
	---	----	----
Total	362	3.32	0.75

Approximately 362 \* 10<sup>6</sup> kg of carbon dioxide was emitted into the atmosphere as a result of energy use on Guernsey in 1990 (not including transportation). The size of the total contribution that parish based cogeneration can make in reducing these greenhouse gases will largely depend upon the amount of conventional heat that is displaced, on a per parish basis. With distributed cogeneration we will show that CO<sub>2</sub> emissions may be reduced by 29% and SO<sub>2</sub> by 88%.

This is achieved by new emissions from the parish cogenerators but important, the reduction in emissions from the conventional 'heat only' boilers and the central power station. The Vale power station now downsized to become the Vale ESCo; no longer supplying the whole Island with electricity and no longer releasing reject heat (and also air pollution) to atmosphere.

Additional references on CO<sub>2</sub> emissions and climatic change are provided in the bibliography.

### The visual impact of parish ESCos

The visual impact of the centralised power station at Vale is dramatic, Figure 98, but the inputs and outputs of each new parish ESCo need not be so.



Visual impact of the centralised power station

Figure 98

The inputs are:-

- (1) Fuel supply
- (2) Water supply<sup>1</sup>

1. In simple terms, the consumption of water on Guernsey is dependent on two principal supply systems. The first constitutes the public system set up by the States Water Board. The second is from a scattering of private wells, boreholes and small reservoirs which are often used to augment supplies to the vinery/horticultural industry.



The outputs are:-

- (1) Electricity
- (2) Heat
- (3) Atmospheric emissions
- (4) Liquid effluent
- (5) Noise and vibration

The emphasis on coastal sites for the siting of small power stations needs to be changed (nowhere is far from the coast on small islands). The abstractions suggest where each ESCo should be located within each of the parishes. Ideally they should be located at the site with the largest heat and/or electricity demand (see TABLES 8.13, 8.14, 8.15 and 8.16).

For the parish of Forest the 'energy hub' has already been identified; located at the site with the largest electricity demand, the States Airport (see Chapter 7).

For the other parishes, the Vale ESCo can remain on the same site as the present centralised power station (near to Juas Quarry), with a significant reduction in the size of the site.

Other ESCo sites could be as follows:-

- (1) The Prison site at St.Sampsons (midway between Les Vardes Quarry and Kenilworth vinery).
- (2) The reservoir site at St.Saviours.
- (3) The Grammar School or Dairy sites at St.Andrews.

(4) The Beau Sejour leisure centre at St.Peter Port.

For the remaining three parishes the choice is more obvious (each have both the largest heat and electricity demands) Castel (King Edward VII Hospital), St.Peter/Torteval (Bader Roses) and St.Martins (Princess Elizabeth Hospital).

All have suitable locations, but important is that all but one (Bader Roses) are owned by the States of Guernsey. All the sites are large (and in many cases already possess standby diesel generators), with more than sufficient space for ESCo cogeneration plant and fuel storage.

#### SUMMARY

(1) Traditional (centralised) energy planning methods are just not appropriate for distributed cogeneration, a thorough (QQT) approach is required.

(2) A suitable way to provide the needed energy services is to create energy service companies (ESCos) that market heat energy as well as electricity.

(3) Fossil fuels must be used to secure these energy services, at least in the short to medium term; energy planning should not be based on wishful thinking.

(4) Domestic buildings play a vital role in energy efficiency; the energy losses of a typical Guernsey home are poor (estimated energy saving opportunities are 75%).

(5) Estimated energy saving opportunities for the other sectors are (a) commercial/public buildings 33% (b) tourism 39% (c) industrial 20% and (d) horticulture/vineries 40%.

(6) The better matching of energy quality within the domestic sector represents a 7% (31 GW) reduction in imports for space/water heating purposes. The prospects in the other economic sectors appear to be poor.

(7) Integrating environmental maintenance into the 'Energy Planning' sub-system model is essential.

(8)  $362 \times 10^6$  kg of carbon dioxide was emitted into the atmosphere as a result of energy use on Guernsey in 1990 (not including transportation).

(9) The size of the total contribution that parish based cogeneration can make in reducing greenhouse gases will be largely dependent upon the amount of conventional heat that is displaced, on a per parish basis (see Chapter 9).

(10) Electric vehicles should be part of our overall strategic energy planning (distributed cogeneration) ethos.

(11) All parishes have suitable locations for distributed cogeneration, all but one is owned by the States of Guernsey; with more than sufficient space for cogeneration plant and fuel storage (in many cases they already possess standby diesel generators).

## CHAPTER 9

### THE QQT MATCHING PROCESS OF THE SYSTEM

The QQT matching process, which is the subject of this Chapter, ensures a supply of 'firm electricity', a supply which is available on demand at all times (distributed energy planning ought not to result in insecure energy supplies).

All this involves the joint production of electricity and heat, which is closely connected with heating networks. Which may produce energy savings that are essential and necessary for very small (densely populated) island communities trying to limit their oil imports.

This work leads to the conclusion that distributed cogeneration may offer the greatest opportunity for energy conservation as a first step, with potential prime fuel (import) savings of 23%. With an additional 'all electric vehicle' scenario these savings may rise to over 31%.

#### 9.1 ESCo flexibility

The potential of cogeneration/heating networks (as a means of saving energy) has been recommended several times by various researchers. The Marshall Report<sup>1</sup> for example, recommended the drawing up of a CHP/DH strategy; the Atkins

1. Report to the Secretary of State by the Combined Heat and Power group chaired by Sir Walter Marshall, U.K. Energy Paper No.35, April 1979.

Report<sup>1</sup> recommended that it should be introduced in 'lead cities' on the U.K. mainland. The House of Commons Select Committee on Energy<sup>2</sup> also agreed that cogeneration "is the best of options when economics, comfort, fuel efficiency and long term environmental benefits are taken into account".

Individual U.K. members of Parliament<sup>3</sup> have also suggested that "whilst millions of people cannot afford enough money to heat themselves to a decent standard, yet, within sight of their homes, we have electricity production wherein 60% of the fuel put into a power station is thrown away as surplus heat".

Even in very small island situations such as Guernsey, this reject heat energy needs to be questioned.

An idealised comparison of heat balances for cogeneration plant and separate production is provided in Figures 99 and 100<sup>4</sup>. For ease of comparison the same electricity and heat output is indicated for both cogen-plant and separate power generation and conventional boiler. 100 Units are consumed by the cogeneration plant compared with the 150 Units to produce the same total energy output.

1. W.S. Atkins and Partners, Consulting Engineers to the U.K. Government, 1982.
2. The House of Commons select committee on energy, third report, 'Combined Heat and Power', April 1983.
3. For example Rost, P, 25 February 1980, Hansard.
4. See Dorgham, W.A, 1982, 'Local heat and power generation: A new opportunity for British Industry'.

# Cogeneration

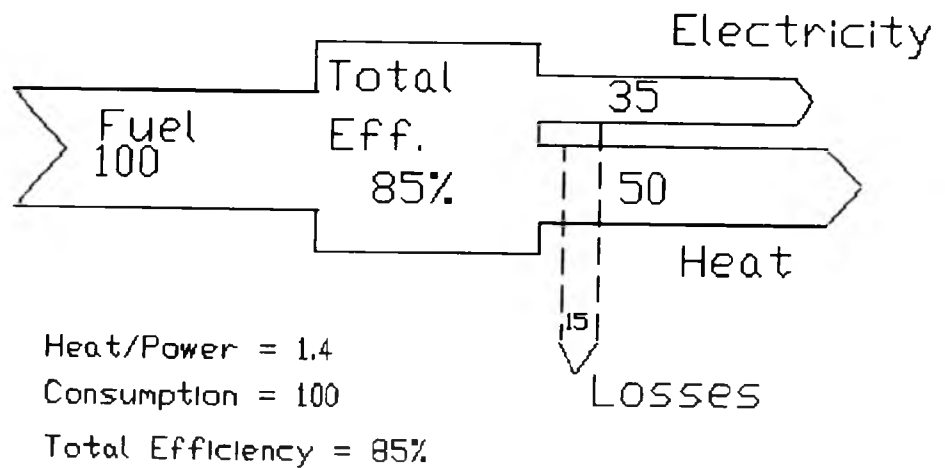

Figure 99

# Separate Conventional

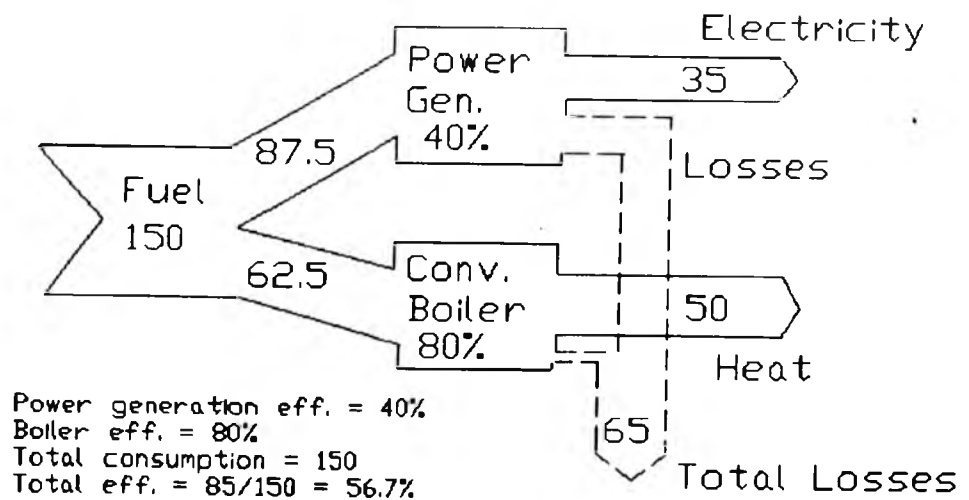

Figure 100

The theoretical saving of prime fuel is 33.33% in favour of the cogeneration plant, but what is the saving in an actual case (island) situation ?

Electrical power is not easy to store, but with storage of hot water it is technically feasible<sup>1</sup>. Short distance transport of low temperature heat should pose few technical problems for each parish ESCo and we test it, in the Island situation, as part of our evaluation of distributed cogeneration.

#### Parish geography and natural endowment

Factors that foster the application of parish power and heating are the significant power and heating loads, the population density of the parish, climate and geographical conditions. As we have shown so far, in end-use energy terms, each parish is very different (the area and population density of each parish is provided in TABLE 9.1).

The way humans have settled on the Island is a key to understanding energy supply and demand, with Islanders tending to cluster their settlement patterns. In terms of energy provision however, the emphasis has been exactly opposite to this, with a move away from local energy services to greater centralisation in the north of the Island.

1. Some storage capacity is available anyway because of the time delay between production and end-use (heat distribution networks and buildings function as a buffer between end-use and cogeneration).

**TABLE 9.1 - Parish area and population density (1991 Census)**

<b>Parish</b>	<b>Area (km<sup>2</sup>)</b>	<b>Pop. density (people/km<sup>2</sup>)</b>
Vale	8.8	1083
St.Sampsons	6.0	1341
Castel	10.1	898
St.Saviours	6.2	390
St.Peter/Tort	9.3	346
Forest	4.2	330
St.Andrews	4.4	536
St.Martins	7.3	833
St.Peter Port	6.5	2561

The arguments usually given for this centralised (large scale generation plant) provision is reduced unit capital cost<sup>1</sup>, low contract (bulk) prices of primary fuel (see Section 4.2), ease of maintenance etc; which are not wholly devoid of merit.

Centralised provision does have some real advantages, although advantages are often subjective. We will show that the advantages claimed for the centralised power station at the Vale however may be illusory. In particular, the need for a wider planning margin and the waste of reject heat.

In 1994 the installed capacity of the centralised power station was 102.2 MWe (see TABLE 5.1), to meet a maximum demand of 58.8 MWe (see Figure 97, Chapter 7); this is a centralised margin of 73.8%.

In contrast, the installed capacity for the parish ESCos is much smaller; Vale (9.87 MWe), St.Sampsons

1. But this does not apply to the large slow-speed diesels used by the States Electricity Board (see Appendix H).



(8.935 MWe), Castel (7.1 MWe), St.Saviours (1.95 MWe), St.Peter/Torteval (3.6 MWe), Forest (1.885 MWe), St.Andrews (1.95 MWe), St.Martins (7.085 MWe) and St.Peter Port (21.8 MWe). A total installed capacity of 64.175 MWe, to meet a distributed parish maximum demand of 52.3 MWe (58.8 MWe - 6.5 MWe demand loss at peak, see Chapter 7). This is a distributed margin of 22.7%.

With distributed cogeneration, greater integration is possible without the need for such a large centralised margin. One of the basic economies is the pooling of generation standby requirements, which is required for unforeseen breakdowns.

Parish energy planning with common 'shared' heat and power demands will lead to a sequence of new investments which are unique to each parish demand/supply model. Such investments are highly location specific and are at the heart of strategic energy planning for each ESCo. We take a particularly relaxed view of costs at this point, but later refine cost estimates for each parish, within a framework of various discount rate and fuel price scenarios (see Chapter 11).

Parish cogeneration plant would be designed to maximise its electrical power output and when further heat is required this will be provided by supplementary boilers<sup>1</sup>.

1. Hot water boilers used as the source of peak-load heat output.

The evaluation of the expected outcome of each ESCo, in the light of fluctuating demand patterns and heat/electricity ratios, is a field which has had little detailed research in the past. Here we focus on actual case (parish) situations<sup>1</sup>.

### Heat Market

Presently, there are no heat transmission networks. The idea of a heating network is the central heating of not one building but a number of buildings in each parish; this wider-ranging 'central heating' being supplied from the local ESCo.

The present centralised power station is located far away from the areas (parishes) which are the markets for heat, and this needs to be changed<sup>2</sup>.

The SEB have failed to introduce cogeneration plant and heating networks as an important extension of their activities. Parish ESCos would address this problem and ensure that the heat market takes its rightful place in true

1. It is important not to forget that it is demand clusters that are vital not necessarily parish boundaries.

The parish was primarily chosen because the political system within the Island is based on rigid parish representation, and this may influence the uptake of alternative energy use/supply technologies locally.

Some inter-parish links though ought to be part of the general system model.

2. Cogeneration and heating networks represent a largely untapped (and unresearched) potential for better energy economy on Guernsey.

energy planning. Now emphasising energy needs and how to supply them rather than just merely electricity needs or (merely again) administratively convenient electricity supplies.

#### **ESCo supply source mix**

The mix of supply sources that are 'economically attractive' and/or 'promising but uncertain' (in the Guernsey context, see Section 8.2) will be shown to be a combination of the following:-

- (1) Cogeneration/supplementary boilers fuelled by Gas Oil.
- (2) Cogeneration fuelled by biogas from landfill or anaerobic digestion of sewage sludge.
- (3) Heat energy from refuse burning.
- (4) Offshore wind power<sup>1</sup>.

ESCos would act as suppliers of Gas (for cooking, if required), electricity, hot water (and maybe the disposal of rubbish and sewage [location specific]), and extracting 'the maximum of useful energy from its resources.

When selecting these energy sources however it is

1. During periods of calm, electricity supply will be met from the output of cogeneration plant, which can be varied continuously and is well suited to making up the difference between demand and the output available from a wind turbine.

See research carried out within the parish of Castel for example; Fielden, D, Jacques, J.K and Laroque, M, 1992, 'Electricity demand and supply matching for the parish of Castel, Guernsey'. The Writer directing the research effort and supervising the field work, locally - University of Stirling internal report.

important and necessary to match them with demand in time (T) [as well as quality (Q) and quantity (Q)]; with the two main timing requirements being:-

- (1) seasonal and
- (2) diurnal.

For both categories the choice of supply source needs to be determined on the basis of (a) quantity of heat required and (b) the heat/power ratio (APPENDIX L provides this data for each of the parish ESCOs).

The balance between heat and power required and that available from the diesel engines has to be carefully assessed. The optimum is clearly when a close match is obtained, and the heat to power ratio effectively defines this balance.

Any operating philosophy has to match these various factors together, but considerable flexibility is available through careful selection of equipment (eg. use of supplementary heat boilers). Daily, even seasonal, storage of heat at the point of use is also straightforward, although local (ESCO) storage may be even easier.

#### 9.2 ESCo QOT models

TABLE 9.2 provides the estimated total annual energy needs of each parish (not including domestic heat demand).

**TABLE 9.2 - Estimated<sup>1</sup> total annual parish energy needs in 1990 (not including domestic heat demand)**

Parish	A Mwt	B MWe	C Mwt	D Mwt
Vale	42001	41725	58957	0
St.Sampson	127975	28475	40235	87741
Castel	35528	21288	30080	5448
St.Saviour	16046	7619	10765	5468
St.P/Tort	40378	8930	12618	27948
Forest	7317	7118	10057	665
St.Andrew	11860	7448	10525	1870
St.Martin	28814	21367	30191	2698
St.P.Port	64856	83277	117671	0
<b>Total</b>	<b>374775</b>	<b>227247</b>	<b>321099</b>	<b>131838</b>

Column A is the ratio estimated process/space/water heating needs of each parish (not including domestic heat demand). Where we assume a consistent relationship between electricity and heat use for the production consumption sectors and again use the same ratio estimators (see Section 7.3). The ratio estimator is applied to the data obtained from each of the parish abstraction sites, in the form of monthly oil product deliveries (using a boiler efficiency of 80%).

Column B is the total sales of electricity for each parish in 1990 (including domestic electricity sales), derived from the Pareto analysis of the SEB electricity billing database described in Chapter 6.

Column C is the heat derived from the cogeneration plant from column B (heat/power ratio = 1.413). Column D is the resulting supplementary heat requirement.

1. See APPENDIX L.

It is necessary though to question whether the total ratio estimated process/space/water heating needs of each parish (Column A) is valid. A comparison is therefore now made with non-domestic primary energy imports in 1990 to confirm this.

Neglecting any Kerosene (17 GW) and LPG (47 GW) used for non-domestic process/space/water heating (Kerosene is used primarily for the provision of CO<sub>2</sub> in vineries and LPG [mains and bottled] for cooking purposes within these sectors). TABLE 9.3 provides the non-domestic energy imports in 1990 (see Figures 30-33, Chapter 5)<sup>1</sup>.

**TABLE 9.3 - Non-domestic primary energy imports used for process/space/water heating purposes in 1990**

	(GW)
Product 469 (Commercial)	21
Product 469 (Vineries)	145
HFO (Vineries)	55
Gas Oil (Comm/Tour/Ind)	68
Gas Oil (Vineries)	18
Coal (Comm/Tour/Ind)	7
Coal (Vineries)	45
	---
<b>Total</b>	<b>359</b>

The ratio estimate is 375 Gwt (total of column A of TABLE 9.2). Assuming boiler efficiencies of 80%, this represents primary energy imports of some 469 GW, 31% above actual imports. Therefore, in order to obtain a more representative heat market, we correct the ratio estimate of TABLE 9.2 (Column A) in TABLE 9.4.

1. Neglecting electric process/space/water heating.

**TABLE 9.4 - Corrected total annual parish energy needs in 1990 (not including domestic heat demand)**

Parish	A Mwt	B MWe	C Mwt	D Mwt
Vale	32151	41725	58957	0
St.Sampson	97965	28475	40235	57730
Castel	27197	21288	30080	345
St.Saviour	12283	7619	10765	1982
St.Peter/Tort	30909	8930	12618	18760
Forest	5601	7118	10057	79
St.Andrew	9079	7448	10525	78
St.Martin	22057	21367	30191	180
St.Peter Port	49647	83277	117671	0
<b>Total</b>	<b>286889</b>	<b>227247</b>	<b>321099</b>	<b>79154</b>

QQT modelling therefore suggests that 208 Gwt of heat energy from distributed cogeneration could be substituted for prime fuel imports<sup>1</sup>. Using boiler efficiencies of 80%, this represents a 260 GW reduction in imports; down from 359 GW to 99 GW (a reduction of 72%).

This begins to set the boundary limits of fluctuation of both total energy demand and of heat and power requirements likely to be experienced by each parish ESCo.

#### **Time bases of heat demand**

We shall now look at two different levels of time demand (seasonal and diurnal), in order to better understand base and peak heat load requirements.

#### **(1) Seasonal timing requirements**

First, seasonal heat variations are considered, the profiles of which can be better appreciated graphically. The seasonal heat energy that is available from the Forest ESCo

1. Total column A - D.

for example (neglecting domestic heat demand) is provided in Figure 101. To maximise energy savings, the cogeneration plant operates as the lead boiler, and the heat output is sufficient to supply nearly all monthly non-domestic heat energy requirements.

The monthly heat energy balances for the remaining eight parish ESCOs (again neglecting domestic heat demand for the moment) are provided in Figures 102-109.

### Forest

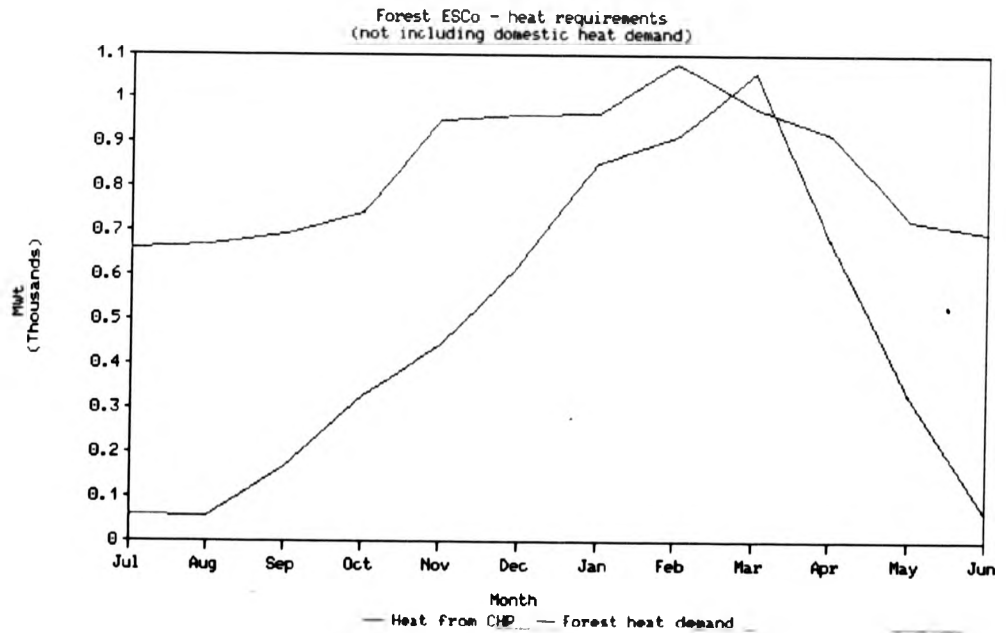

Figure 101



**Vale**

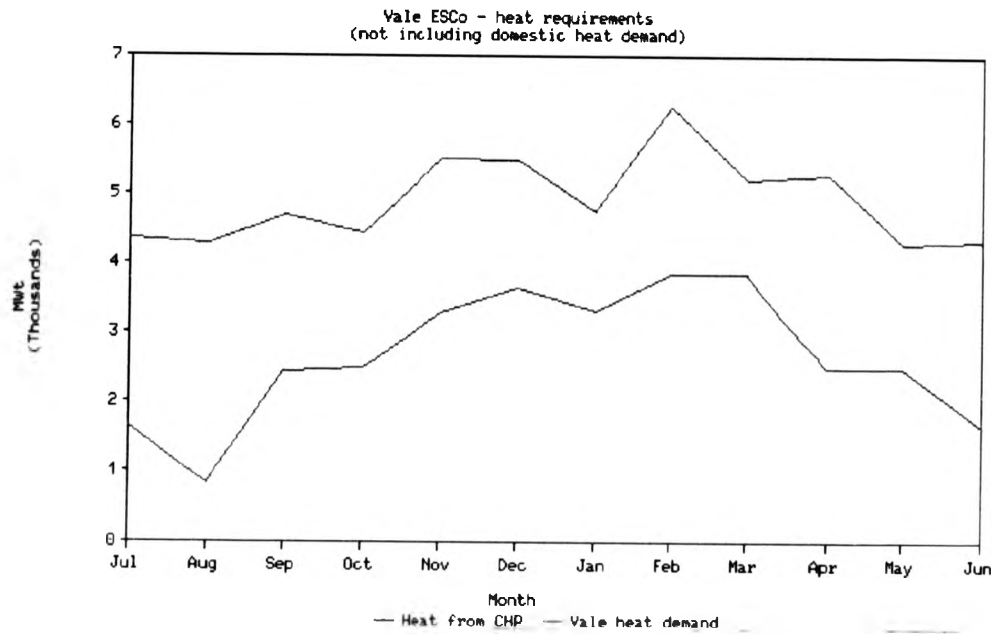

Figure 102

**St. Sampsons**

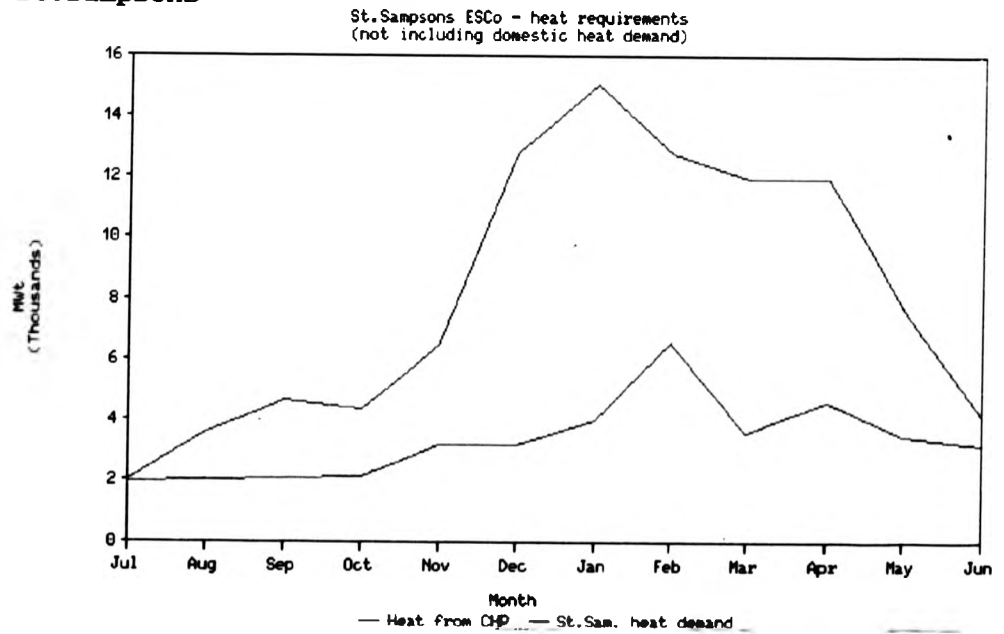
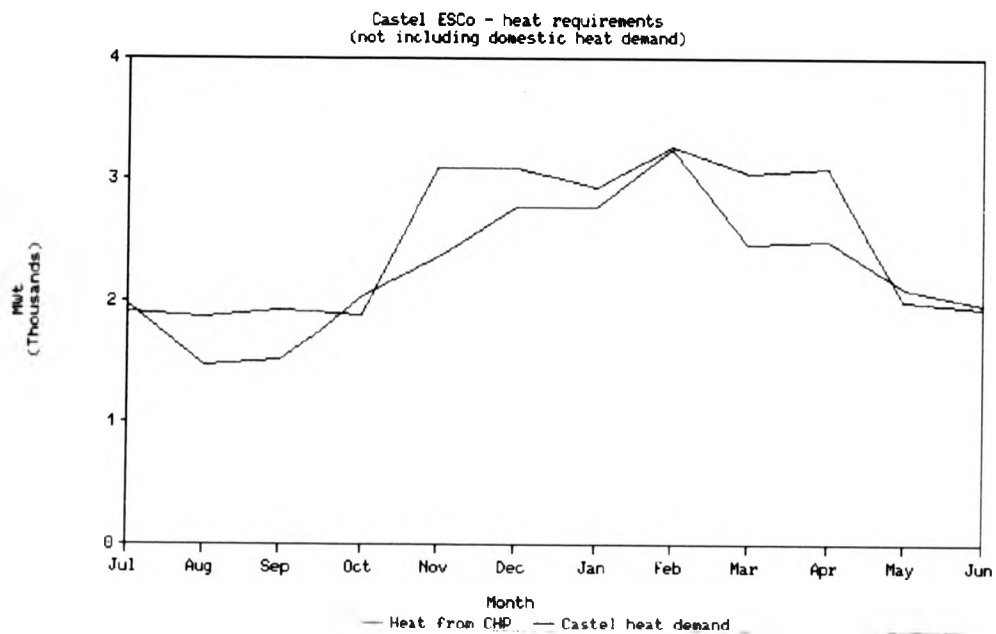

Figure 103

**Castel**



**Figure 104**

**St.Saviour**

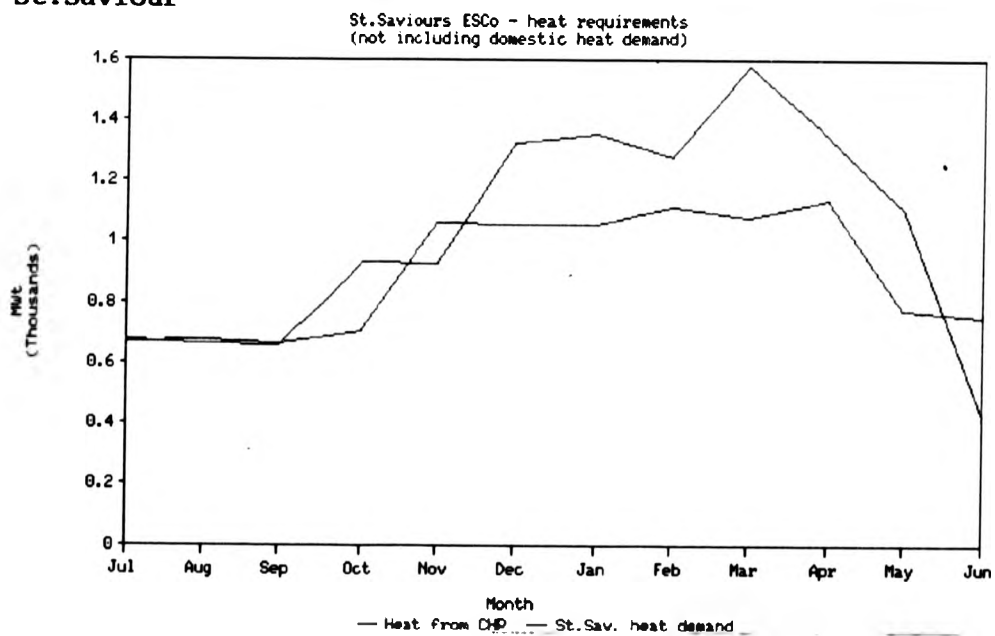

**Figure 105**

**St. Peter/Torteval**

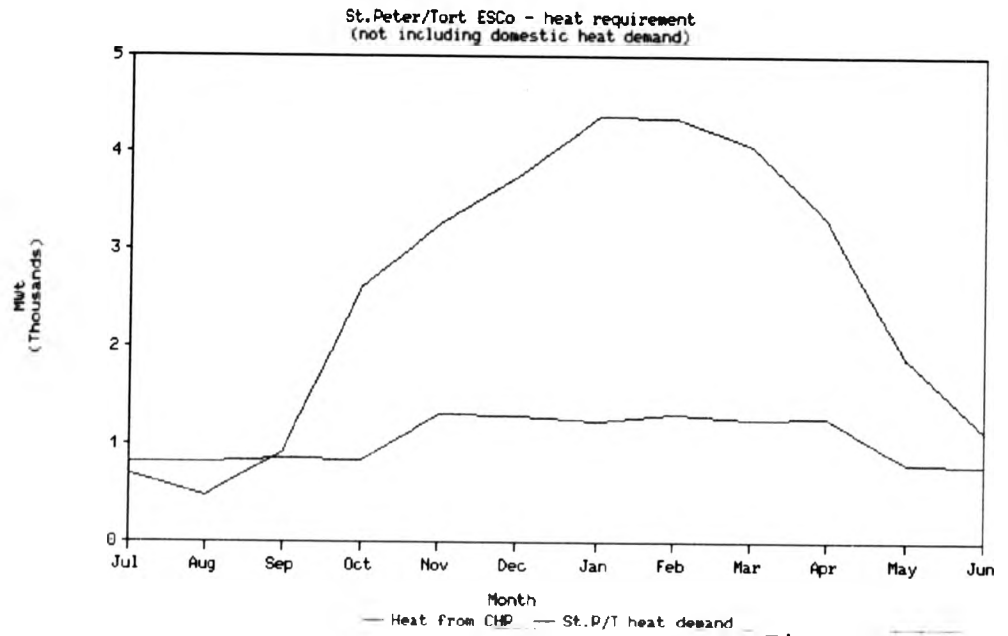

Figure 106

**St. Andrews**

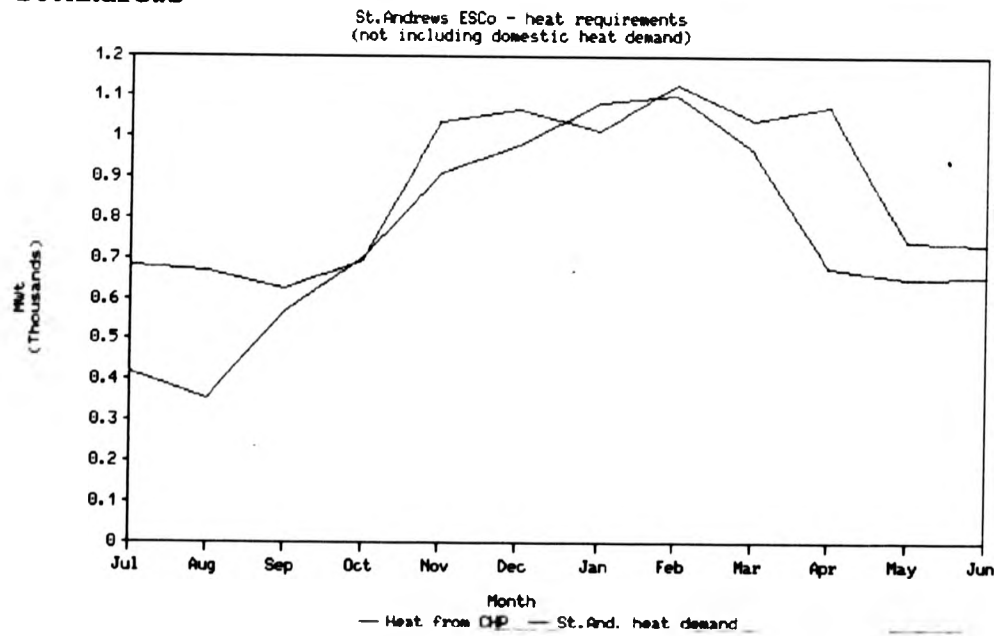

Figure 107

**St. Martins**

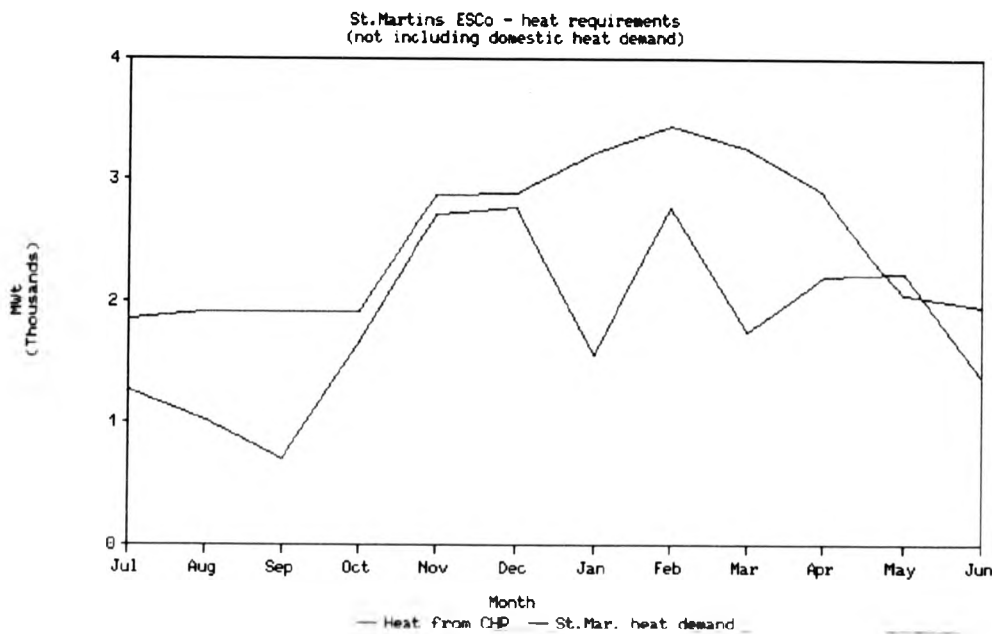

Figure 108

**St. Peter Port**

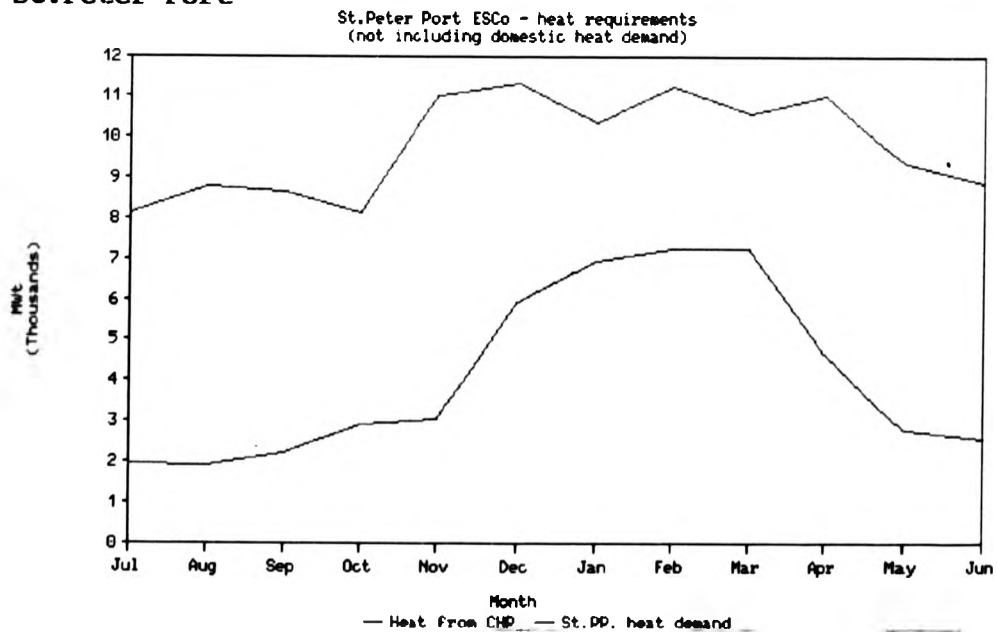

Figure 109

QQT modelling indicates that even after all non-domestic heat demands have been met in all parishes (and supplementary heat of 79 Gwt supplied) there is still 113 Gwt (35%) of reject heat available<sup>1</sup>, TABLE 9.5.

**TABLE 9.5 - Parish energy balances after all non-domestic heat demands have been met**

	Remaining reject heat (Mwt)	Supplementary heat requirement (Mwt)
Vale	26806	0
St.Sampsons	0	57730
Castel	3228	345
St.Saviours	464	1982
St.P/Tort	469	18760
Forest	4535	79
St.Andrews	1524	78
St.Martins	8314	180
St.P.Port	68023	0
	-----	-----
	113363	79154

Good energy planning should aim to eliminate this remaining reject heat also, but in order to achieve this, some domestic end-users will need to be connected to the parish heating networks<sup>2</sup> (see the discussion on the different levels of energy service delivery, Section 7.6)

The QQT domestic heat load that is necessary to totally eliminate this remaining reject heat is shown in TABLE 9.6. Where monthly domestic heat needs are modelled on the basis of typical 900 litre Kerosene deliveries to households (typically, two 900 litre deliveries made to domestic

1. From TABLE 9.4 (Column C - [Column A - Column D]).

2. The relatively long hours of heating make the domestic sector an attractive thermal load.

households per year<sup>1</sup>; see APPENDIX L).

**TABLE 9.6 - The domestic heat load that is required to maximise 'customer use of waste heat'**

	%	Number of end-users
Vale	100	3406
St.Sampsons	0	0
Castel	31	944
St.Saviours	59	506
St.P/Tort	48	534
Forest	100	487
St.Andrews	79	628
St.Martins	89	1937
St.P.Port	100	6333
		-----
		14775

All of this is very dependent upon location specific energy imbalances<sup>2</sup>, which will strongly influence the approach to energy planning within each of the parish ESCos.

After these domestic heat demands have been met (and further supplementary heat of 210 Gwt supplied) there is still 19 Gwt of reject heat within Vale, Forest and St.Peter Port (6%), TABLE 9.7. However, this may be then further substituted for some of the supplementary heat requirement by inter-parish links for example.

APPENDIX L provides the monthly heat averages for each of the parish ESCos.

1. Total (Sarnia) Limited, 1993, personal communication.

2. A cogeneration unit whose thermal output is used for domestic space heating is in a favourable position. Its highest outputs would tend to coincide very closely with the highest demands for electricity.

TABLE 9.7 - Parish energy balance after all non-domestic + domestic heat loads are connected

	Remaining reject heat (Mwt)	Supplementary heat requirement (Mwt)
Vale	-3046	28229
St.Sampsons	0	57730
Castel	0	11530
St.Saviours	0	9245
St.P/Tort	0	26446
Forest	-1216	4194
St.Andrews	0	8141
St.Martins	0	21426
St.P.Port	-14596	43240
	-----	-----
	-18858	210181

We now have to consider the likely effect of all of this on the Island energy flows, first derived in Chapter 5 (and shown later in tabular form in TABLE 9.10), as follows:-

(a) With maximum use of waste heat (321 Gwt from parish QQT modelling; see APPENDIX L) there is a further supplementary heat requirement of 191 Gwt (210 Gwt - 19 Gwt); which represents 239 GW of prime fuel (see TABLE 9.7).

In maximising the use of this waste heat, 14,775 domestic Island households have to be supplied from the heating networks (see TABLE 9.6). Rather than the present 13,153 (ie the present number of households with domestic central heating; see 'System Three Scotland' survey, Section 8.4). These 1,622 additional households are essential and necessary in order to secure maximum 'customer use of waste heat'.

(b) The domestic primary energy imports used for space/water heating purposes in 1990 is shown in TABLE 9.8 (see Figures

30-33, Chapter 5)<sup>1</sup>.

**TABLE 9.8 - Domestic primary energy imports used for space/water heating purposes in 1990**

	(GW)
Gas Oil	10
Kerosene	159
LPG	78
Coal	135
	---
<b>Total</b>	<b>382</b>

The number of domestic end-users that are NOT required to be connected to the heating networks are shown in TABLE 9.9.

**TABLE 9.9 - Number of end-users not supplied by the heating networks (once waste heat has been maximised)**

Parish	No. of end-users not supplied
Vale	0
St.Sampsons	2999
Castel	2102
St.Saviours	352
St.P/Tort	527
Forest	0
St.Andrews	167
St.Martins	239
St.P.Port	0
	----
	<b>6386</b>

Once all waste heat has been used, 6,386 domestic end-users (30%) still require fuel for domestic space/water heating purposes. Taking into account the previously neglected Kerosene for CO<sub>2</sub> provision in vineries (17 GW) and LPG for cooking purposes (47 GW), along with the 321 GW of

1. Neglecting electric space/water heating.



now useful heat from cogeneration (see APPENDIX L). This suggests the annual fuel requirement for this group to be in the order of 99 GW.

With suitable regulatory control it may then be possible to replace the environmentally poor fuels such as Coal, HFO and Product 469 imports, with the consequence of a new Island energy balance, TABLE 9.10.

**TABLE 9.10 - Estimated Island energy balance with all non-domestic + domestic heat loads connected**

	Primary energy imports (1990) (GW)	Primary energy imports with distributed cogen. (GW)
HFO/Product 469	780 <sup>1</sup>	
Gas Oil	102	886 *
Kerosene	176	116
LPG	125	47
Coal	187	0
	-----	-----
	1370	1049
<b>Transport</b>		
Gas Oil	114	114
Motor Spirit	366	366
Avtur	54	54
Avgas	9	9
	----	----
	543	543
<b>Static plant</b>	3	3
	-----	-----
<b>Total</b>	<b>1916</b>	<b>1595</b>

\* Cogeneration primary fuel (647 GW to produce 227 GWhe of electricity [see TABLE 11.1, Chapter 11]).

These figures suggest that distributed cogeneration on Guernsey (based upon its parishes) may offer potential

1. See TABLES 9.3, 9.7 and Chapter 5.

prime fuel (import) savings in the order of 23%. Not the idealised prime fuel saving of 33.33% (see Section 9.1) but nevertheless significant.

The comparison between actual 1990 imports on the one hand and the QOT modelling of the distributed future on the other, suggests significantly less dependence on outside fuels. Imported fuel equivalent to centralised losses is saved through alternative cogeneration and transmission schemes.

#### (2) Diurnal timing requirements

Diurnal heat requirement variations are now considered, and supplementary heat boilers sized for each ESCo. This sizing has to relate to maximum peak hourly demand, because the operating scenario is ad libitum supply (which refers to the underlying assumption; with no changes to behaviour).

Hour by hour heat demand is very difficult to assess or simulate in a realistic manner but it is necessary in order to allow accurate boiler plant sizing and reduces the risk of installing the wrong size of supplementary heat boiler.

The risk is that the supplementary boiler could be either 'undersized', which would be a major problem, or 'oversized' and loose out on efficiency<sup>1</sup> and capital outlay factors.

1. For the current state of heat recovery technology (heat exchangers etc) see U.K. Energy Efficiency Office 'Good Practice Guide 13', 1990.

To realistically size the supplementary heat boilers the real world of fluctuating energy demands needs to be investigated further. The aim here is to set the more realistic boundary limits likely to be experienced.

Diurnal electricity usage patterns have already been determined by actual site measurements (see Section 6.2). In the absence of measured diurnal HEAT demand patterns inferences will need to be drawn from the combination of ESCo monthly heat averages and some specimen hourly measurements taken in important demand sectors (eg. vineries).

Computer modelling can again help here by simulating these fluctuation possibilities. This is an extension of the QOT energy planning approach and employs seasonal heat and power fluctuations based upon random usage patterns as one component of the simulation process, and a Monte Carlo method of simulation is adopted<sup>1</sup>.

We will take the parish of Forest as an example. A first assumption will be that the distribution of monthly heat from cogeneration and monthly ESCo heat demands in the future corresponds to those of past years; this is represented by TABLES 9.11 and 9.12.

1. The concepts of random sampling probability are explained by: Jackson, M, 1988, 'Advanced spreadsheet modelling with Lotus 123' and also Ball, R, 1991, 'Quantitative approaches to management'.

TABLE 9.11 - Derived<sup>1</sup> monthly heat averages from cogeneration for the Forest ESCo (H/P ratio = 1.413)

	MWht	f (%)	Cumulative probability
July	661	6.6	0.066
August	670	6.7	0.133
September	695	6.9	0.202
October	743	7.4	0.276
November	950	9.5	0.371
December	962	9.6	0.467
January	969	9.6	0.563
February	1081	10.8	0.671
March	980	9.7	0.768
April	919	9.1	0.859
May	729	7.2	0.931
June	698	6.9	1.000

TABLE 9.12 - Monthly heat average demands<sup>2</sup> for the Forest ESCo

	MWht	f (%)	Cumulative probability
July	370	2.8	0.028
August	367	2.8	0.056
September	479	3.7	0.093
October	1258	9.7	0.190
November	1374	10.5	0.295
December	1557	11.9	0.414
January	1785	13.7	0.551
February	1844	14.2	0.693
March	1989	15.3	0.846
April	993	7.6	0.922
May	642	4.9	0.971
June	377	2.9	1.000

The simulation approach takes random samples from the cumulative probability distributions and then evaluates boundary limits for sizing hot water supplementary boilers. This is done in order to come closer to a 'meta-reality' which embraces unforcastable random events.

1. See APPENDIX L.

2. See APPENDIX L.

If the samples are random<sup>1</sup> and if sufficient samples are selected, a range of expected supplementary heat requirements can be determined. The worst case is minimum waste heat from cogeneration plant with maximum parish heat demand.

The cumulative probability curves convert the random numbers into a sequence of random cogeneration contributions (MWt) and ESCo heat demands (MWt) from each distribution. This procedure is repeated for 100 numbers and so generates a random sample of contributions and demands.

The results obtained in the simulation are the results obtained from a stream of random numbers. In other words, it gives only one out of a whole distribution of possible output values.

The advantage is that each simulation can be run many times to test repeatability. With 200 trials a far more realistic annual requirement for supplementary heat can then be determined.

As a first step the annual heat demands are simulated,  
TABLE 9.13.

1. Within SuperCalc 5 a pseudo-random number is produced deterministically from recursive routines running between 0.000 and 1.000.

TABLE 9.13 - Probable annual - minimum ESCo cogeneration heat contribution and maximum ESCo heat demand

	Minimum ESCo cogen. heat (Mwt)	Maximum ESCo heat demand (Mwt)
Vale	51932	93419
St.Sampsons	33128	127668
Castel	29887	45547
St.Saviours	10445	22926
St.P/Torteval	11806	50618
Forest	9520	16606
St.Andrews	10083	21650
St.Martins	28339	60921
St.Peter Port	109191	192965

The probable maximum winter monthly heat average consumption for the Forest ESCo is therefore 2534 MWh (ratio estimated from APPENDIX L).

These provide 'bench mark' levels of averaged monthly and hence daily heat consumption.

Simply averaging over the number of days in the month to obtain a 'maximum' winter diurnal heat load is not appropriate, because the diurnal heat loads may not peak on the same day (see the 'coincidence factor'/'diversity factor' discussion in Section 7.6).

Here we use the same diversity factor as for the electricity usage patterns derived earlier (for each parish abstraction). This also has severe limitations since there is no a priori reason to believe that on any day, peaks in electricity and in heat demands would occur simultaneously. Nevertheless, this does not invalidate the construction at the aggregated 'bench mark' level of argument.

In the case of Forest, the probable diurnal heat

average consumption of 82<sup>1</sup> MWht is multiplied by its diversity factor of 1.515 = 124 MWht to represent the probable maximum diurnal heat average consumption.

The next step is to relate this 'bench mark' level of demand to an hour-by-hour heat load profile. This hourly profile has to be simulated on the basis of small amounts of directly measured data, refer Jacques et al<sup>2</sup>. Measurements undertaken by Utilicom Limited<sup>3</sup> for the SEB (1983) for example, based upon typical boiler running times within the Kenilworth vinery at St.Sampsons, can be used to provide typical hourly data for one of the most important heat demand sectors, locally.

Hour by hour (diurnal) heat demand records were taken for various months of the year. The heat profile with the greatest energy demand was used for our modelling purposes, and is appropriate in most parishes with a vinery sector (Sovereign Flowers in the Forest for example).

The only other additional (significant) local parish (Forest) heat demand comes from the domestic sector. For modelling diurnal domestic heat demand our sample profile is taken from an average 'Direct Acting Space Heating (DASH)'

1. For the Forest, 2534/31 = 82 MWht/day.
2. Jacques, J.K, Lesourd, J.B and Ruiz, J.M, 1988, 'Modern applied energy conservation'.
3. This work was undertaken to enquire into a possible one-off waste heat utilisation proposal from the central power station.

profile provided by the U.K. Electricity Association<sup>1</sup> (the profile was derived (not measured) from econometric research).

Hence, a composite 'worst' (maximum) heat demand case can then be delineated, Figure 110.

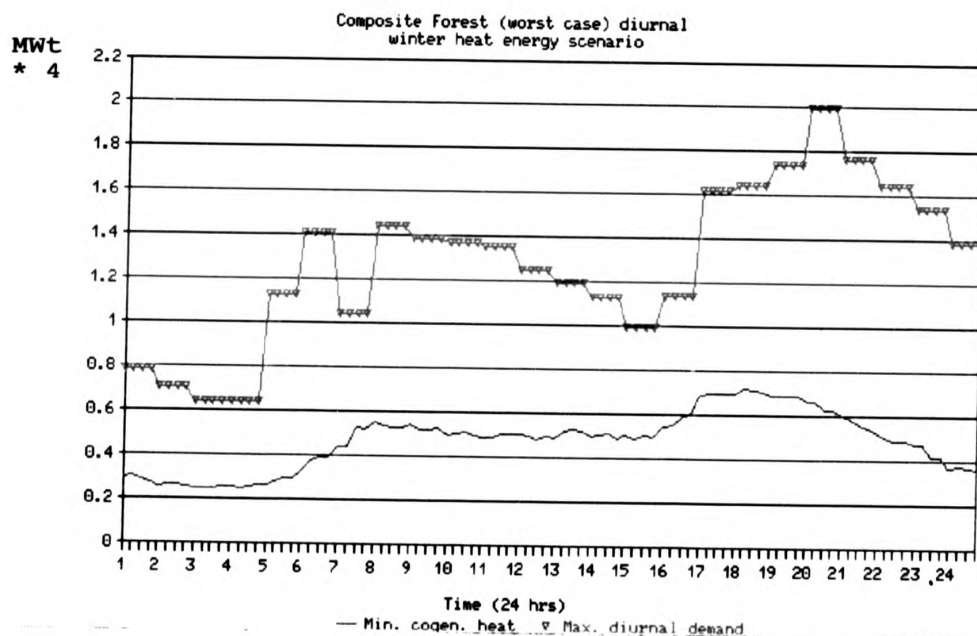

Figure 110

The diurnal electricity usage pattern has already been derived for the Forest ESCo from computer modelling, Figure 94 (see Chapter 7). The heat energy available from the cogeneration waste heat boiler has the same profile.

The probable minimum (winter) monthly cogeneration heat

1. Electricity Association (Taylor, L.K), 1992, personal communication.



average income for the ESCo (see TABLE 9.13 and APPENDIX L; and using the same approach, for the same winter month) is 927 MWht. The consequent diurnal heat average income of 30<sup>1</sup> MWht, again multiplied by the diversity factor of 1.515, represents a probable minimum diurnal cogeneration heat average contribution of 46 MWht.

Probable maximum diurnal heat load (124 MWht) is greater than that available from probable minimum diurnal cogeneration heat contribution (46 MWht). Perfect matching does not exist and a diurnal (worst case) supplementary heat requirement of 78 MWht is required.

If all the heat demands occurred simultaneously many more boilers would have to be installed. For the Forest ESCo, supplementary heat boilers of 6 MWh capacity are required.

Four other parishes (Vale, St.Saviours, St.P/Tort and St.Andrews) have the vinery and domestic sectors as significant components of local parish heat demand. TABLE 9.14 shows the most important heat demand sectors for all parish ESCos, derived from APPENDIX L.

1. For the Forest, 927/31 = 30 MWht/day.

TABLE 9.14 - The most important HEAT demand sectors for each parish

	Vinery	Domestic	Comm/P.Bldg	Tourism	Ind
Vale	37%	62%	-	1%	-
St.Sampson	70%	-	30%	-	-
Castel	-	35%	58%	7%	-
St.Saviour	43%	38%	16%	3%	-
St.P/Tort	74%	21%	-	5%	-
Forest	31%	57%	6%	6%	-
St.Andrew	22%	51%	17%	-	10%
St.Martin	5%	57%	32%	6%	-
St.P.Port	3%	66%	26%	5%	-

For St.Sampsons, access to the Prison to obtain directly measured heat data was impossible, consequently the vinery diurnal profile was used in this case (since vineries are a significant contributor, 70%). For Castel and St.Martins (both hospitals) diurnal heat demand was measured at the Princess Elizabeth Hospital and the profile used for both cases. For St.Peter Port, diurnal heat demand at Beau Sejour was measured.

APPENDIX M provides these sample diurnal heat profiles, which help to back-up our assertions on 'peaks', 'base load' and 'expected' (probabilistic) incomes from cogeneration.

APPENDIX N provides the probable composite (maximum) diurnal heat demand profiles for the remaining parish ESCos.

Hot water boilers can now be more accurately sized for the parish ESCos, TABLE 9.15, and included in any economic

assessment (see Chapter 11).

TABLE 9.15 - Supplementary heat boiler sizes for each ESCo

Parish	MWt
Vale	28
St.Sampsons	120
Castel	12
St.Saviours	8
St.P/Torteval	20
Forest	6
St.Andrews	7
St.Martins	16
St.Peter Port	72

The further thermal storage of surplus heat energy (to meet heat demands that do not necessarily coincide with conditions of energy production) occur at the margins and are not considered in any detail in the present work.

Importantly, the financial significance of extra supplementary boiler capacity is small (see Chapter 11), so that minor errors in peak estimation are not crucial to the overall argument.

### 9.3 Location specific renewable sources

It is now necessary to ask whether distributed cogeneration offers the greatest energy saving opportunity when compared with those available from local (promising) renewable sources.

#### Wind power

Wind power is the source of renewable energy with the fastest growing uptake (the most likely use is in the generation of electricity). The major drawback though is the impact on the environment, where the main areas of concern

are:-

- (1) Visual impact.
- (2) Noise.
- (3) Interference with flora and fauna (especially noted in recent work has been bird-kills).
- (4) Land-use.

They are not pretty and whilst they are non-polluting they are a dominant feature on any landscape<sup>1</sup>. The siting of windmills is therefore a very emotive issue and as such needs parish end-user participation in any decision making<sup>2</sup>.

Most wind turbine development is currently based on land rather than off-shore, in order to provide easy access and cheap construction. However, on islands like Guernsey, environmental and land use constraints restrict such development. New installations sited offshore (in shallow waters near to the coast) may offer an alternative solution and it is this option we consider.

Offshore, the wind resource is in many areas greater (and more constant) and such problems as visual impact, noise, interference with flora and fauna and land use can be

1. See Webb, J, 1994, 'Can we learn to love the wind' or  
Lee, T, Wren, B and Hickman, M, 1988, 'Public responses to the siting and operation of wind turbines'.
2. See Guernsey Evening Press, 23 January 1992, 'The eye of the beholder' and  
Guernsey Evening Press, 24 January 1992, 'Siting wind turbines'.

avoided. Guernsey is fortunate in having a large number of rocky islets offshore, and it is here that we concentrate our attention.

Offshore wind turbines (such as those of Danish construction, see Chapter 8) sited on parish islets would operate at 690 V using an induction generator, excitation would be provided by reactive power drawn from the Island electricity network. A transformer placed in the bottom of the tower of each wind turbine would step up the output to 11 kV and then feed into the Island 11 kV network. The distance from each wind turbine to the 11 kV network would be less than 0.5 km, in all cases.

Interpretation of raw data from the Guernsey meteorological office enables TABLE 9.16 to be produced, which provides the average annual percentage frequency of winds in various velocity bands. The raw data refers to a measuring anemometer located at the Airport at a height of 12m. For conversion from an anemometer height of 12m to a wind turbine hub height of 25m we use the formulae<sup>1</sup>:-

$$V_h = V_a (25/12)^{0.133} = 1.1025 V_a$$

$V_h$  = hub height       $V_a$  = anemometer height

1. See Swift-Book, D.T, 1989, 'Wind energy and the environment'.

**TABLE 9.16 - Average annual percentage frequency of winds in various velocity bands (m/sec)**

Wind velocity (@ 12m)	Wind velocity (@ 25m)	f, % frequency (in all directions)
0 - 0.22	0 - 0.25	0.6
0.22 - 1.56	0.25 - 1.73	3.6
1.56 - 3.35	1.73 - 3.70	10.7
3.35 - 5.59	3.70 - 6.16	25.4
5.59 - 8.27	6.16 - 9.12	36.5
8.27 - 10.95	9.12 - 12.08	14.8
10.95 - 14.08	12.08 - 15.53	5.9
14.08 - 17.21	15.53 - 18.98	1.9
17.21 - 20.79	18.98 - 22.92	0.5
20.79 - 24.36	22.92 - 26.86	0.1

The actual power output of a wind turbine is provided in Figure 111, as a function of wind velocity V, according to the performance curve of a typical 300 kWe unit. The industry at present seems to be concentrating cost reduction efforts on units of about 300 kWe (which is a suitable scale for Guernsey).

The electrical energy extracted in a given frequency group is given by:-

$$E = P * f/100 * 365 * 24 \text{ kWh}$$

P is read from Figure 111 which corresponds to each mean velocity and the energy extracted is then indicated in TABLE 9.17.

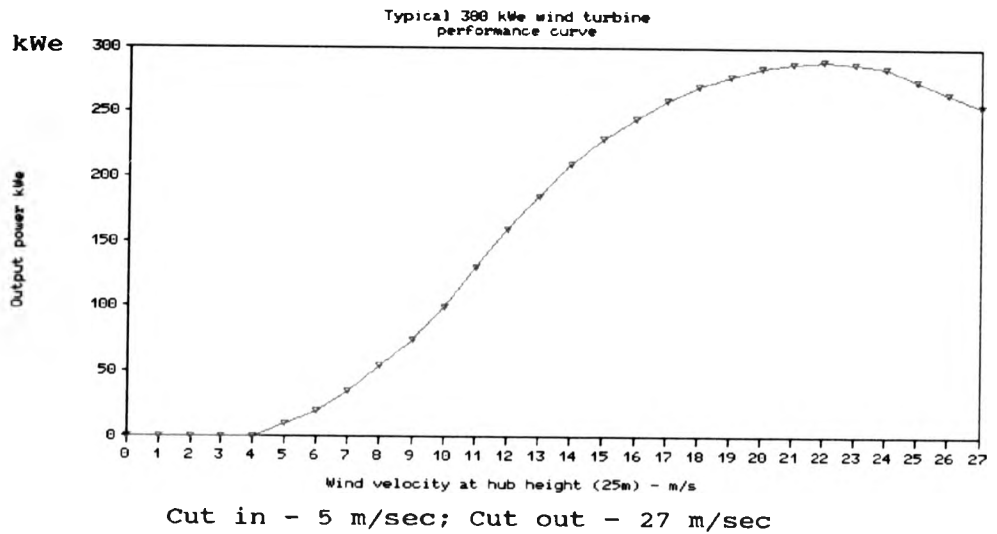

Figure 111

**TABLE 9.17 - Energy extracted from a 300 kWe wind turbine  
(from measurements at the Airport)**

V mean at hub height of 25m (m/sec)	f, % frequency (all directions)	Extracted energy (kWe)
0.13	0.6	0
0.99	3.6	0
2.72	10.7	0
4.93	25.4	22250
7.64	36.5	143883
10.60	14.8	149095
13.81	5.9	104156
17.26	1.9	43274
20.95	0.5	12614
24.89	0.1	2435
	-----	-----
	100.0	477709

478 MWe is the calculated electrical energy return per annum at this land based site. The seasonally extracted electrical energy is provided in Figure 112, which can be seen in a general way to suit conditions of peak winter electricity demand.

### QOT of a typical 300 kWe land based (Airport) wind turbine

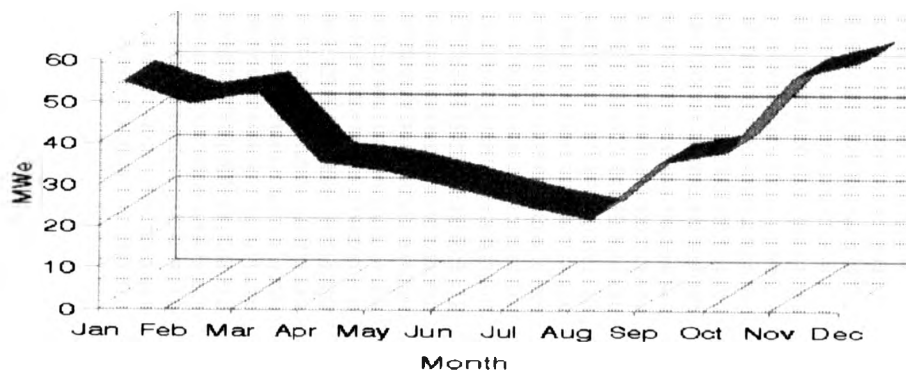

Figure 112

There are four major types of output fluctuations (T) related to wind turbines, these are momentary, daily, seasonal and annual variations. The momentary fluctuations involve small power output fluctuations in individual machines. Daily output fluctuations occur because of the changes in wind speeds which take place over a 24 hour cycle. Seasonal and annual variations indicate a tendency for higher mean wind speeds in the winter months when energy demand is greatest.

Important is the question as to what proportion of electricity can be supplied by wind turbines on the Island. Because of the possible electrical integration problems that might be experienced from a supply source that is far more



variable than cogeneration plant<sup>1</sup>.

It is generally accepted that as long as wind power capacity remains about 10% of total capacity, problems related to variability and unpredictability remain insignificant. On this basis, TABLE 9.18 provides the wind power potential for each parish ESCo.

**TABLE 9.18 - Offshore wind power contribution to parish ESCos**

Parish	kWe
Vale	900 (3 * 300 kWe)
St.Sampson	600 (2 * 300 kWe)
Castel	600 (2 * 300 kWe)
St.Saviour	300 (1 * 300 kWe)
St.Peter/Tort	300 (1 * 300 kWe)
Forest	n/a (too near Airport)
St.Andrew	n/a (no coast line)
St.Martin	600 (2 * 300 kWe)
St.Peter Port	n/a (shipping <sup>2</sup> )

Wind energy offshore has been found to be 60% higher than on land<sup>3</sup>. In the Guernsey context, offshore mean wind speeds 30% and 60% greater than the land based Airport site would (by calculation) provide annual energy contributions (for one machine) of 832 MWe and 1123 MWe respectively.

So far, analysis of wind power has been based upon

1. See Grubb, M.J, 1987, 'The integrated analysis of new energy sources on the British supply system' or

Grubb, M.J, 1991, 'The integration of renewable electricity sources' for example.

2. Wind turbines would interfere with shipping into and out of St.Peter Port harbour.

3. See Jespersen, K.D, October 1991, 'First offshore windfarm starts up'.

actual measurements, but in order to examine a real-life situation (and observe turbine behaviour) we again use Monte Carlo simulation.

First we assume that the distribution of wind velocity in the future corresponds to that of past years, represented by the '% frequency (in all directions)' column in TABLE 9.16.

Cumulative probability distributions for the land based site and also offshore sites (with wind velocity 30% and 60% greater than the land based site) are modelled, Figures 113, 114 and 115.

Random samples from the assessed distributions are again taken and used to evaluate the contributions wind power might make to each parish ESCo. If the samples are random and if sufficient samples are selected, a range of expected wind power contributions can be determined.

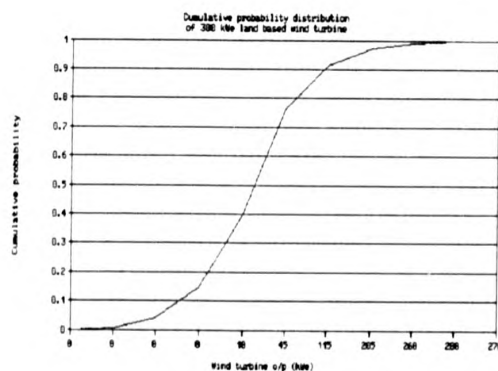

Cumulative probability distribution for land based site

Figure 113

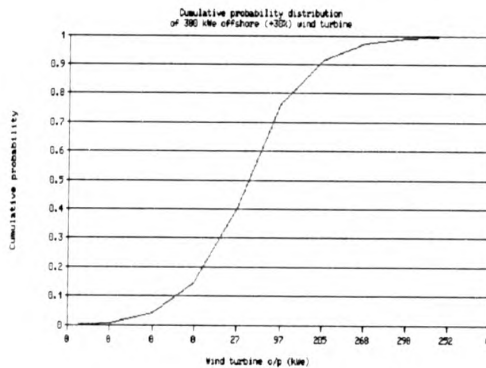

Cumulative probability  
distribution for offshore  
(+ 30% wind velocity) site

Figure 114

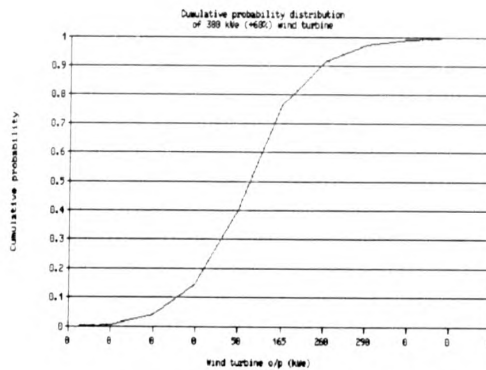

Cumulative probability  
distribution for offshore  
(+ 60% wind velocity) site

Figure 115

The cumulative probability curve converts the random numbers into a sequence of random wind turbine outputs (kWe) from each distribution. This procedure is repeated for 100 numbers as before and so generates a random sample of wind turbine outputs.

With two hundred trials, the probability distribution for wind power can then be determined, Figures 116, 117 and 118.

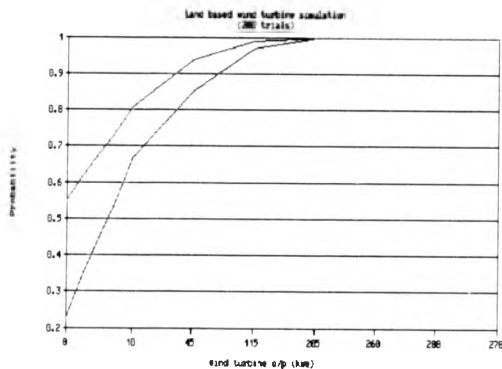

Land based wind turbine simulation shows that the probability (min & max) of a wind turbine o/p of 50 kW is 14% (maximum).

Figure 116

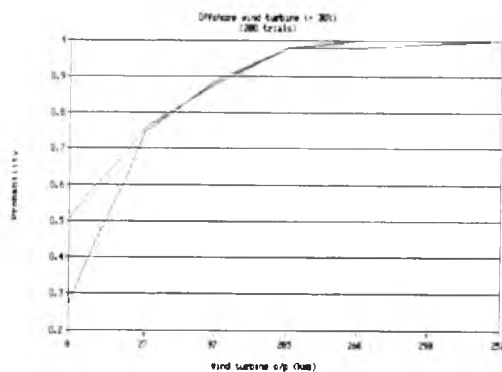

Offshore (+ 30%) wind turbine simulation shows that the probability (min & max) of a wind turbine o/p of 50 kW is 20% (maximum).

Figure 117

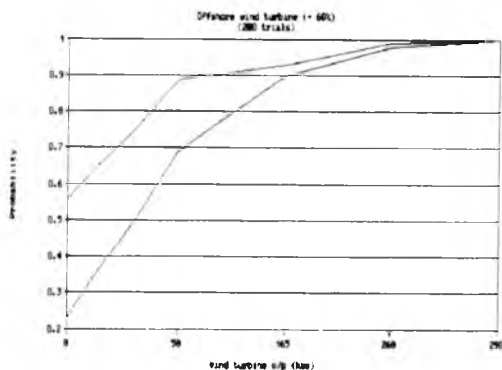

Offshore (+ 60%) wind turbine simulation shows that the probability (min & max) of a wind turbine o/p of 50 kW is 30% (maximum).

Figure 118

From the simulations a far more realistic picture of wind energy incomes can then be determined, TABLE 9.19.

TABLE 9.19 - Probable minimum and maximum annual wind energy incomes (300 kWe turbine)

	Minimum MWe	Maximum MWe
Land based:	121	284
Offshore (parish islets):		
+ 30%	273	508
+ 60%	364	748

#### The Vale cluster

The natural bacterial decomposition of organic materials (in the absence of oxygen) results in the production of a methane rich biogas. This process of 'anaerobic digestion' has been known of since historical times and has more recently on the U.K. mainland been put to good use in reducing the polluting effects of domestic sewage and other wet wastes.

This same process of decomposition also takes place in a landfill site, which in many ways can be thought of as a very large anaerobic digester. Organic materials contained in the refuse are attacked by bacteria as in conventional digesters (under conditions of oxygen exclusion)<sup>1</sup>.

1. For references see Richards, K, 1990, 'Power generation from landfill gas' or

Richards, K, 1989, 'Landfill gas - a global review' or

Richards, K, 1989, 'All gas and garbage'.

Bordeaux quarry in the Vale has been the Island's landfill site for virtually all waste products (except occasionally horticultural matter for composting), for over twenty years (opened in 1971 and closed in 1992).

Although solid waste is a parish responsibility, all the refuse produced by each parish is collected by a private contractor and transported to the landfill site. However, two major problems are associated with such sites:-

- (1) The release of the methane (a potent greenhouse gas).
- (2) Leachate contamination of water courses.

Landfill gas is widely recognised as a potential health hazard, and the Bordeaux landfill site (75m deep and over 3 hectares) is considered to pose a significant risk from landfill gas migration. Daily measurements of methane taken from monitoring pipes have shown levels in excess of 50% being recorded<sup>1</sup>. Such a site may be able to provide an energy contribution to the Vale ESCo and we consider its 'energy saving' potential here.

The rate at which gas is produced in landfill sites varies from location to location. Influenced by characteristics such as the hydrogeology of the site and the composition of the refuse. The important factors controlling the amount of gas produced are the size of the site, the amount and rate of biodegradable waste input, the waste

1. See Land Use Consultants, August 1989, 'Waste management strategy for Guernsey'.

densities and the moisture content of the waste<sup>1</sup>.

There is no typical figure for the length of time that landfill gas will be produced; at some sites gas production can be expected to continue for a period of at least 16 years after the last deposit of waste. As the reaction progresses, gas production declines approximately 3% to 5% annually.

Evaluation of the landfill site at Bordeaux was assisted by O'Brian Energy Europe Limited<sup>2</sup>. The landfill gas production figures for the site were based upon extrapolated waste input from 1971 to 1989. The earlier years are estimates but should not appreciably alter the present day gas production rates (unless the figures are vastly underestimated).

The tonnages are based purely on the putrescible waste input. Although other biodegradable matter is present in the landfill (such as paper), the quantities involved should not drastically alter gas production.

The annual electrical energy available (over a sixteen year period), is estimated in Figure 119.

1. The quantity of waste arising on Guernsey and the range of wastes for our analysis was taken from the Land Use Consultant's study and also the planning inquiry for the Chouet headland (Billet d'Etat XXI 1988).
2. O'Brian Energy Europe Limited, personal communications, 1991/92, using their computer based landfill gas production analysis model.

### Bordeaux landfill gas analysis - derived electrical energy over 16 years

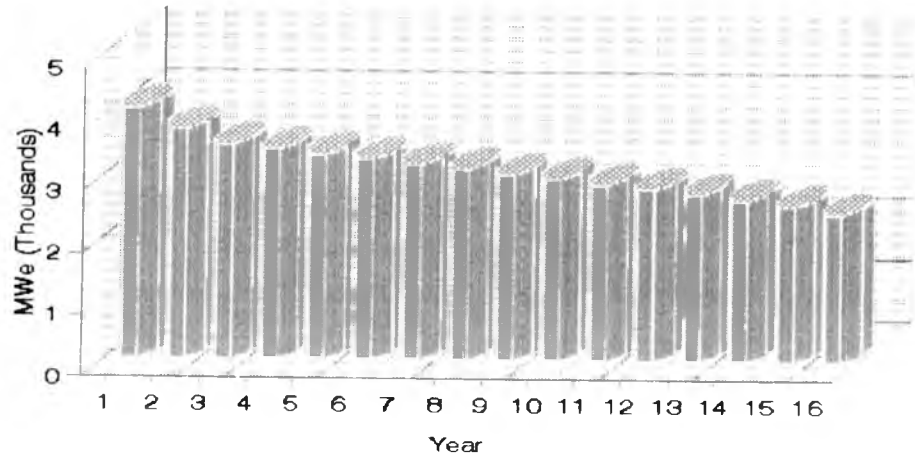

Figure 119

TABLE 9.20 estimates the annual electrical energy displacement (ie. the amount of electrical energy that may not be required to be generated by cogeneration) within the Vale cluster.

Landfill gas represents 8% and wind energy 2-4% of the Vale annual electricity requirement. The annual heat available from the landfill gas scheme is 4651 Mwt (17% of Vale's supplementary heat requirement, see APPENDIX L).



TABLE 9.20 - Annual electrical energy displacement (Vale cluster)

	MWe (Min)	MWe (Max)
Landfill gas <sup>1</sup>	3256	3256
Wind turbines (3 * 300 kWe <sup>2</sup> )	819	1524

#### The St.Sampson cluster

Refuse disposal is a serious problem facing all island communities, but the burning of such refuse may also have an 'energy saving' potential and we consider it here. Refuse burning is a suitable heat source as well as a useful way of diverting waste away from landfill sites.

The practice of filling quarries with refuse on Guernsey has become commonplace due to the development of a modern throw-away society. It has been argued by others<sup>3</sup> that the Island needs all its quarry sites for future reservoirs, due to increasing population and possible global warming.

The relative environmental benefits of waste incineration (compared to other forms of treatment and disposal) are difficult to quantify. Generally it is considered that incineration by correctly designed plant is

1. Taking annual electrical energy availability for the first year.
2. Using offshore parish islet locations with + 30% wind velocity.
3. See Planning Inquiry, 1988, 'Chouet headland' for example.

an environmentally acceptable way of treating waste<sup>1</sup>.

Recovery of the heat released by the combustion of domestic waste has taken various forms, but the schemes involved usually employ the heat from combustion to provide a heat source for heating networks.

Acceptance of an incinerator however, needs the participation and full agreement of St.Sampson's end-users. Important is that this parish has the largest non-domestic heat demand of all the parishes (see TABLE 9.4, column A) and is also the most suitable place to locate an incinerator.

The quality of waste available for burning on Guernsey is summarised in TABLE 9.21.

TABLE 9.21 - Refuse available for burning on Guernsey

	Total (t/annum)	Quantity available for burning (t/annum)
Household & commercial	27000	27000
Civic amenity	6900	3000
Construction & demolition	141000	-
Horticultural	15000	15000
Other	6600	3000
	-----	-----
<b>Total</b>	<b>199000</b>	<b>48000</b>

1. Although since the 1970s there has been increasing concern over the effect of flue gases on air pollution. The presence of organic chlorinated micropollutants (dioxins and furans) is the subject of much discussion at present.

For references see ETSU, 1990, 'A review of mass burn incineration as an energy source' or

House of Lords select committee on the European committees, 1989, 'Air pollution from municipal waste incineration plants'.

The average daily load =  $48000/365 = 131.5$  tonnes/day.

To allow for summer load peaks, an allowance of 25% increase on the daily throughput has been made. Assuming that the plant is not available for 20% of the time, the daily design capacity is 190.6 tonnes/day (ie.  $131.5 + 131.5 * 20/100 + 131.5 * 25/100$ ). Which gives a rate of throughput of 7.9 tonnes/hr.

The minimum required design capacity of the plant is therefore 8 tonnes/hour.

The calorific value of domestic waste is extremely variable. A typical figure for household and commercial waste on the U.K. mainland would be 2389 kcal/kg. For the purposes of the present work the calorific value of Guernsey's waste is taken as 2000 kcal/kg<sup>1</sup>, slightly lower than average to take into account the high percentage of horticultural waste (and its higher water content).

TABLE 9.22 estimates the annual electrical energy displacement within the St.Sampson cluster.

**TABLE 9.22 - Annual electrical energy displacement (St.Sampson cluster)**

	<b>MWe (Min)</b>	<b>MWe (Max)</b>
Wind turbines (2 * 300 kWe)	546	1016

Wind energy represents 2-4% of St.Sampson's annual

1. 8000 kg/hr, equivalent to  $16*10^6$  kcal/hr which represents 18.56 MW/hr (1 kcal = 0.00116 KW).

electricity consumption. The annual heat available from the refuse incinerator scheme is 91048 MWt (137% of St.Sampson's supplementary heat requirement).

#### The St.Peter Port cluster

Bellegrave sewage plant/pumping station is located on the periphery of St.Peter Port and disposes of 93% of the Island's sewage; approximately 90,000,000 litres per week.

The plant was designed to discharge sewage through one very long outfall into the Little Russel, and was approved by the States of Deliberation in April 1968. The outfall stretches from a 45 metre deep shaft on the shore, out under the road in a long tunnel beneath the beach for about 1.2 km, then into a seabed pipeline where it is discharged.

Anaerobic digestion could again be used within this cluster to:-

(a) Provide a positive solution to the environmental problems caused by the disposal of raw sewage<sup>1</sup>.

Reports of sewage coming ashore on Island beaches (such as Fermain) have been made<sup>2</sup>; it may therefore be ecologically sound to end this practice.

(b) The methane rich biogas may also have 'energy saving' potential when used for electricity generation, and our

1. See Hall, J.E, 1991, 'Alternative uses for sewage sludge' for example.

2. See Guernsey Evening Press, 6 March 1991, 'Pollution on Guernsey beaches'.

research effort (assisted by Mass Energy Limited<sup>1</sup>) considered the design of a suitable plant to handle the domestic sewage sludge produced by an Island population of 58,000 people.

The analysis relates to domestic sewage sludge and not pig, poultry, dairy and plant wastes which are all capable of yielding a combustible biogas<sup>2</sup>.

As well as the generation of electricity, the remaining liquor can be stored and used for spreading on agricultural land as a fertiliser. Once digested all the nutrients in the organic material are readily available to plants and can be applied during the growing season (this could provide a useful fertiliser for the vinery/horticultural sector).

We estimate the quantity of biogas produced to be 60m<sup>3</sup>/hour; if liquid/solids are separated, the quantity of solids produced would be approximately 9 - 12 tonnes per day.

Derived electrical energy (from the primarily domestic sludge) would provide between 1920-2400 kWh per day using a 110 kWe CHP unit, with recovered hot water used for digester heating.

TABLE 9.23 estimates the annual electrical energy displacement within the St. Peter Port cluster.

1. Mass Energy Limited, 1991/92, personal communications.
2. An isolated example of this resource however, on a particular farm, may prove an interesting source of energy for that farm.

TABLE 9.23 - Annual electrical energy displacement  
(St.P.Port cluster)

	MWe (Min)	MWe (Max)
Anaerobic digestion	631	788

Anaerobic digestion represents 0.76-1% of St.Peter Port's annual electricity consumption.

TABLE 9.24 now provides an overall picture of the energy savings from using these renewables.

TABLE 9.24 - Estimated annual energy savings due to the use of renewables

Parish	Wind (max) MWe	Other MWe	Other MWT
Vale	1524	3256	4651
St.Sampsons	1016	0	91048
Castel	1016	0	0
St.Saviours	508	0	0
St.Peter/Torteval	508	0	0
Forest	0	0	0
St.Andrews	0	0	0
St.Martins	1016	0	0
St.Peter Port	0	788	0
	-----	-----	-----
	5588	4044	95699

The substitution of imported prime fuel which would accrue to the Island from using these renewables are now ranked against those of distributed cogeneration, TABLE 9.25.

**TABLE 9.23 - Annual electrical energy displacement  
(St.P.Port cluster)**

	<b>MWe (Min)</b>	<b>MWe (Max)</b>
Anaerobic digestion	631	788

Anaerobic digestion represents 0.76-1% of St.Peter Port's annual electricity consumption.

TABLE 9.24 now provides an overall picture of the energy savings from using these renewables.

**TABLE 9.24 - Estimated annual energy savings due to the use  
of renewables**

<b>Parish</b>	<b>Wind (max) MWe</b>	<b>Other MWe</b>	<b>Other MWh</b>
Vale	1524	3256	4651
St.Sampsons	1016	0	91048
Castel	1016	0	0
St.Saviours	508	0	0
St.Peter/Torteval	508	0	0
Forest	0	0	0
St.Andrews	0	0	0
St.Martins	1016	0	0
St.Peter Port	0	788	0
	----	----	-----
	5588	4044	95699

The substitution of imported prime fuel which would accrue to the Island from using these renewables are now ranked against those of distributed cogeneration, TABLE 9.25.

**TABLE 9.25 - Substitution of imported prime fuel, ranked in order of energy saving**

	GW
Distributed cogeneration	321 <sup>1</sup>
Refuse burning	114
Wind turbines	16
Landfill	15
Sewage	2
	---
	468

In terms of energy saving (when ranked against distributed cogeneration) the refuse burning incinerator (located at St.Sampsons) makes the most significant contribution to reducing prime fuel imports.

Distributed cogeneration could meet Guernsey's bulk demand for energy, but there is also an important economic ranking to consider, which we discuss later in Chapter 11.

#### 9.4 Computer aided planning of the heating networks

We have shown that, in terms of energy saving feasibility, the introduction of distributed cogeneration WILL reduce Guernsey's dependence on oil imports (as a first step).

Computer modelling can now also help in planning the required heating networks<sup>2</sup>. The geographic information system (GIS<sup>3</sup>) operated by the SEB is again used to provide a digitised map base of the Island for heat network planning

1. See TABLE 9.10.

2. See Roslund, S, 1983, 'Computer aided planning of CHP/DH systems' for an example of this.

3. Developed by 'Alper Systems' of Cambridge, England.



purposes<sup>1</sup>.

A simplified heating network was produced (for the purposes of feasibility) for each parish ESCo, and Figures 120-127 provide the general routes and proposed location of each ESCo (see Section 8.5).

#### Vale ESCo/heating network



Figure 120

Red - Existing central power station

Scale: 1cm = 100m

1. Also used by the Writer for electricity network design/  
management planning purposes.

**St.Sampson ESCo/heating network**

**Figure 121**



Scale: 1cm = 100m

**Castel ESCo/heating network**



Yellow - Location  
of ESCOs

Scale: 1cm = 170m

**Figure 122**

**St.Saviour ESCo/heating network**

**Figure 123**



Scale: 1cm = 100m

**St.Peter/Torteval ESCo/heating network**

**Figure 124**



Scale: 1cm = 100m

**St.Andrew ESCo/heating network**



Scale: 1cm = 170m

Figure 125

**St.Martin ESCo/heating network**



Scale: 1cm = 170m

Figure 126

St. Peter Port ESCo/heating network



Scale: 1cm = 75m

Figure 127

In order to examine the economic implications of these heating networks it is necessary to consider their technical description (ie. for capital investment and annual operation/maintenance cost purposes). Economic feasibility is therefore discussed in Chapter 11 and provides (and can only provide within the scope of the present work) budgetary estimates for sizing the networks and overall costs. Further work will be required to refine these estimates, but our approach is to consider feasibility and to provide later an overview of the economic outcomes of distributed

cogeneration<sup>1</sup>.

### 9.5 Supply/demand uncertainty

In 1989 the SEB's engineering consultants forecast a 73% increase in Island electricity demand over the next twenty years<sup>2</sup>. This was derived from an analysis of sectoral electricity sales by SEB tariff category, TABLE 9.26.

**TABLE 9.26 - Ewbank Preece forecast of electricity sales up to the year 2010, by economic sector**

<b>Domestic</b>	- 2.7% to 1998/99; 2.5% thereafter
<b>Commercial</b>	- 5% to 1993; 2.5% thereafter
<b>Tourism</b>	- 1% per annum
<b>Industrial</b>	- 5% to 1994; 2.5% thereafter
<b>Vineries</b>	- No increase

The actual outturn for the three years following the forecast is given in TABLE 9.27.

**TABLE 9.27 - Electricity sales for the three years immediately after the 1989 Ewbank Preece forecast**

	1990/91	1991/92	1992/93
<b>Domestic</b>	+ 2.67%	+ 6.43%	- 1.19%
<b>Commercial</b>	+ 1.28%	+ 5.95%	- 0.71%
<b>Tourism</b>	+ 12.84%	- 0.52%	- 3.28%
<b>Industrial</b>	+ 10.99%	- 0.49%	+ 2.06%
<b>Vineries</b>	+ 0.69%	+ 2.77%	+ 15.69%

1. See Combined Heat and Power Association, 1990, 'Guide to the implementation of combined heat and power community heating systems', for guidance on planning such networks.

2. See Ewbank Preece Limited, 1989, 'Review of generation development'.

It would seem that the reliability of the forecast, even in the short-run, is questionable. The influence of reduced electricity tariffs for the vinery sector in 1992/93 is also evident<sup>1</sup> (ie. a normative-style policy change). Forecasters may therefore be right only rarely and conventional forecasting (with its spurious precision) may be of little real use in good energy planning.

A more appropriate approach (which we use in the present work) is to emphasise the importance of **UNCERTAINTY** (ie. as in the Monte-Carlo method for example<sup>2</sup>), **INNOVATION** (ie. as with distributed cogeneration) and **ENTREPRENEURSHIP** (ie. the energy service company idea, see Chapter 12).

Our QQT energy planning approach is at the heart of all of these implications and focuses attention on location specific (parish) energy demands. Inviting each ESCo to think about what action to take in the light of the range of these probabilistic outcomes.

TABLE 9.28 provides a parish annual (1990) electricity consumption matrix, which shows that in every parish (except Forest, St.Andrews and St.Peter Port) domestic electricity consumption is the dominant sector (see also TABLE 7.11).

1. A special electricity 'growers' tariff was introduced in 1992/93.

2. The probability distribution contains far more information than a single-point estimate.

TABLE 9.28 - Annual (1990) parish electricity consumption matrix by economic sector (GWe)

	Domestic	Comm	Tourism	Ind	Vineries
Vale	15.6	5.3	1.6	2.0	1.4
St.Sampson	13.5	6.6	0.4	3.4	2.6
Castel	14.7	4.4	1.6	0.7	0.8
St.Saviours	4.6	1.1	0.4	1.1	0.6
St.P/Tort	5.9	1.2	0.7	0.0	1.1
Forest	2.6	2.6	0.7	0.0	1.3
St.Andrew	4.2	1.9	0.1	2.3	0.5
St.Martin	11.1	5.8	3.2	0.0	0.9
St.P.Port	30.0	41.0	7.7	3.5	0.6

The commercial sector dominates St.Peter Port; commercial and domestic electricity sales are equal in Forest. Industrial electricity consumption is location specific in St.Sampsons and St.Peter Port.

These location specific patterns may assist in longer term energy (contingency) planning. Such questions as:

"where shall any future incoming large energy end-user be located ?" for example, could be considered against this energy pattern (with consideration given to the maximisation of 'customer use of waste heat' and inter-parish links, as discussed in Section 9.2). With future developments specifically designed to avoid peak stimulation.

#### 9.6 Smooth demand curves

This 'gap-filling' should aim to produce smooth electricity demand versus time curves in order to remove any rapid changes in gradient (which will further improve energy conversion efficiency).

A 'spot pricing' approach is a feasible method of smoothing demand by using two-way electronic information



linking energy end-users and the ESCo via dedicated links<sup>1</sup>. 'Spot pricing' is a concept where the price of energy varies in response to the cost of supply/demand and supply/demand conditions. This is not considered in any detail in the present work but others have published in this area of study<sup>2</sup>.

Parish based electric vehicles is another feasible method but important is that it may offer a further energy saving opportunity, particularly for very small island communities. Electricity generation is far more efficient when demand is consistent and the fact that recharging electric vehicles would take place at night (plus the fact that peak transport demand is generally in the summer) may help in achieving a more steady state solution.

Parish based transport complements our distributed energy planning (offering the service of mobility) and we now examine how its introduction might affect electricity load curves, time patterns and important produce further energy savings.

1. End-user controllers shed and restore major loads during peak periods to keep energy use at or below a desired level. The three major applications are:-
  - (1) Responding to 'time of day' tariff rates.
  - (2) Responding to a rate activated under ESCo command.
  - (3) Taking specific action under ESC control.

The actions of the end-user to shift energy depend upon the incentives provided by the parish ESCo and the needs of the end-user. Such 'real-time' marketing may help to achieve steady-state (smooth) demand profiles.

2. See for instance Deering, S, Newborough, M and Probert, S.D, 1992, 'Rescheduling electricity demands in domestic buildings'.

In 1992 Brown et al<sup>1</sup> considered the introduction of electric vehicles into each parish. The average distance travelled from each parish was estimated in relation to the introduction of three sizes of electric vehicles; 14 kWhe, 20 kWhe and 25 kWhe. Roughly mirroring popular small, medium and large domestic ICE vehicles.

A QQT spreadsheet model was produced to derive the electrical demand that would be created if EVs were introduced into each of the Guernsey parishes.

The total number of private vehicles within each parish (1986 Census) was estimated to have EV sizes of 28% (14 kWhe), 54% (20 kWhe) and 18% (25 kWhe), TABLE 9.29.

EV ranges were based upon figures released by manufacturers; 80 miles (14 kWhe), 130 miles (20 kWhe) and 130 miles (25 kWhe). A rotation of charge (in days) was provided for each vehicle size, which was calculated by dividing the range of each size of vehicle by an estimated daily journey length.

1. Brown, R.P, Fielden, D and Jacques, J.K, 1992, 'Electric Vehicles: An alternative transportation system for Guernsey'; University of Stirling internal report. The present Writer directing the research effort and supervising the field work, locally.

TABLE 9.29 - Electric vehicles within each parish ESCo

	Vehicles of each size			Avg daily jrnery (ml)	Rotation of charge
	14kWhe	20 kWhe	25 kWhe		
Vale	1249	2422	806	18	4 7 7
St.Sampson	962	1856	621	18	4 7 7
Castel	1144	2223	739	25	3 5 5
St.Saviours	376	728	242	23	3 5 5
St.P/Tort	470	911	303	26	3 5 5
Forest	202	392	130	26	3 5 5
St.Andrew	412	588	176	24	3 5 5
St.Martin	817	1584	527	25	3 5 5
St.P.Port	1700	3295	1096	16	4 8 8

TABLE 9.30 shows the additional parish electricity requirements due to the introduction of these EVs (vehicle charging requirements are dependent upon the size of the battery).

TABLE 9.30 - Parish ESCo electricity requirement with EVs

	Daily electricity consumption (kWe)	Annual electricity consumption (MWe)
Vale	11336	4138
St.Sampson	7641	2789
Castel	14769	5391
St.Saviours	4701	1716
St.P/Tort	5882	2147
Forest	2529	923
St.Andrew	4124	1505
St.Martin	10223	3731
St.P.Port	14090	5143
-----	75295	27483

The electricity consumption due to EV charging is determined by the charging requirement of the vehicle, multiplied by the number of vehicles of that size, divided by the rotation of charge. Total ESCo daily electricity requirement is then determined by summing the daily electricity requirement for each of the three vehicle sizes.

Parish electricity demand for EV charging was then mapped onto each of the final parish ESCo load duration curves. The smoothing (levelling) of the demand curves is achieved during the night in all of the parishes except St. Peter Port, where the EV charging load is small. However, since only private EVs have been considered and not commercial EVs such as buses, trucks etc (which would probably be charged in St. Peter Port anyway). It may be possible to achieve smooth demand curves within this parish also. If the private 'all electric vehicle' energy service of mobility was also introduced into each parish, then yet a new Island energy balance would result, TABLE 9.31.

**TABLE 9.31 - Estimated Island energy balance (taken from TABLE 9.10) now with the additional energy service of mobility**

	Primary energy imports (1990) (GW)	Primary energy imports with distributed cogen. (GW)
HFO/Product 469	780	0
Gas Oil	102	964 *
Kerosene	176	116
LPG	125	47
Coal	187	0
	-----	-----
	1370	1127
<b>Transport</b>		
Gas Oil	114	114
Motor Spirit	366	0
Avtur	54	54
Avgas	9	9
	---	---
	543	177
<b>Static plant</b>	3	3
	----	----
<b>Total</b>	1916	1307

\* Cogeneration primary fuel (78.3 GW to produce 27.48 GWe of electricity for EVs [see TABLE 9.30]).

The EV may therefore be an important additional service and also an important energy efficient solution to Guernsey's transport problems<sup>1</sup>. It is discussed here only in order to illustrate the scope for further reduction in Island petroleum product imports (within our distributed cogeneration ethos) and to also aid in producing steady-state models of electricity demand (but this may not be easy to achieve). This will then produce further reject heat to be planned (with further tunnels and further lights at the end of etc).

With distributed cogeneration, potential prime fuel (import) savings of 23% may be possible (see TABLE 9.10). With ESCOs offering the energy service of mobility, this may rise to over 31%.

#### SUMMARY

(1) Distributed energy planning ought not to result in insecure energy supplies.

(2) The advantages claimed for the centralised power station at Vale have been shown to be illusory. In particular, the need for a wider planning margin (centralised 73.8%, compared with distributed 22.7%) and the waste of reject heat.

1. The EV owner does not necessarily have to recoup the whole cost of the vehicle, but only the difference in initial cost between an EV and an ICE.

(3) The present centralised power station is located away from the areas (parishes) which are the markets for heat and this needs to be changed.

(4) Each ESCo should act as a supplier of Gas (for cooking, if required), electricity, hot water (and maybe the disposal of rubbish and sewage [location specific]). Extracting the maximum of useful energy from its resources.

(5) Nearly two thirds of reject waste heat can be utilised (with supplementary heat of 79 Gwt) by connecting all non-domestic heat loads to heating networks. The domestic heat load that is necessary to totally eliminate all reject heat is very dependent upon location specific (parish) energy imbalances.

(6) Computer aided planning of heating networks is useful in producing geographic heat plans.

(7) Location specific consumption patterns can assist in long term energy (contingency) planning; with future developments specifically designed to avoid peak stimulation.

(8) The opportunities for exploiting biofuels and wind energy on the Island are necessarily location specific. In terms of energy saving (when ranked against distributed cogeneration) the refuse burning incinerator (located at St.Sampsons) makes the most significant contribution to reducing prime fuel imports. Distributed cogeneration could meet Guernsey's bulk demand for energy.

(9) A more appropriate approach to conventional forecasting may be to emphasise the importance of UNCERTAINTY (ie. as in the Monte-Carlo method for example), INNOVATION (ie. as with distributed cogeneration) and ENTREPRENEURSHIP (ie. the energy service company idea, see Chapter 12).

(10) Distributed cogeneration offers the greatest opportunity for energy conservation (as a first step). It offers potential prime fuel (import) savings of 23%; with ESCos offering the energy service of mobility, this may rise to over 31%.

## CHAPTER 10

### THE VECTORS FOR, AND CONSEQUENCES OF CHANGING THE SYSTEM

All of the proposed changes to the system will necessarily result in a number of consequences, the most important of which are the subject of this Chapter.

It leads to the conclusion that energy is too important to Guernsey to be left to market forces alone. Conscious management of the long-term development of the energy sector is an essential requirement. However, in order to achieve this, a complete turnaround of existing structures and attitudes are required; with distributed cogeneration determined (effectively imposed) by the States of Guernsey through the SOGEMS.

#### 10.1 A case for the States to look at energy in a total systems sense

There has to be good reasons for changing the system; the arguments in favour of distributed energy planning so far are:-

- (1) A reduction in primary energy imports into the Island (as a first step).
- (2) Reduced Island exposure to primary energy shortages and price inflation.

We will also show that there may be three further reasons:-

- (3) It may improve the overall energy efficiency of the Island electricity network, and increase its flexibility



(which we discuss in this Chapter<sup>1</sup>).

(4) It may offer the possibility of lower energy prices for parish end-users (see Chapter 11).

(5) It may provide a cleaner environment (see Chapter 12).

The question of how far this is the responsibility of the individual end-user, or the States of Guernsey, is a question of particular relevance to Guernsey, where the States have traditionally shown itself reluctant to intervene.

It is the case that many individual Island end-users (particularly domestic end-users) have seen the financial wisdom of home insulation and efficient appliances. Many have at least lagged their hot water cylinders and insulated their lofts.

It could be argued that this shows that there is no need for the States to intervene, for it is the individual end-user who stands to benefit. Regardless such a view may be mistaken when considered from an Island perspective.

In broad terms the management of scarce resources (such as energy imports) requires an active approach. This is an area where the States can intervene effectively in order to facilitate change in the right direction. The objective is

1. When large centralised generating sets are installed, a single breakdown leads to a much greater capacity loss. With cogeneration located near to end-users, improved service reliability may be possible.

to secure energy conservation through the implementation of distributed cogeneration (as a first step).

To initiate such action (in a holistic way) there are three requirements:-

- (1) An appropriate planning structure.
- (2) The possible requirement for a source of adequate funds.
- (3) A target at which to aim.

Profitability, growth and ROI are all important and common measures at the business level, but at the Island level (see Section 1.6) a more systemic view is essential. Rather than ignoring other vital processes, it accounts and embraces them.

At the 'Island level' a true sense of energy priority can be achieved<sup>1</sup>.

We have already shown that there exists on the Island a profligate waste of heat energy due to centralised energy provision (see Section 5.3). In order to correct this situation, it will be necessary to change traditional energy planning (ie. quantitative methods of relating supply decisions to demand forecasts, see Section 8.1) and set the process of energy strategy making in a much wider mould.

Presently it is not clear which department of the

1. However, the pursuit of energy conservation is not, and can never be, an absolute aim. The States of Guernsey need also to take into account economic efficiency in the Island economy as a whole, and we discuss this in Chapter 11.

States of Guernsey is responsible for the task of providing strategic guidance. The SEB cannot be expected to provide such guidance, although it is probably the only organisation in the Island best qualified to offer an opinion. The SEB would clearly face a conflict of interest; this matter of conflict of interest would also seem to be a major problem in a wider context.

This unsatisfactory position in part derives from the Guernsey system of government, which consists of a number of autonomous committees with no effective co-ordination or control (see Section 1.2).

Chapter 5 has shown that electricity on Guernsey has grown considerably over the years. Driven by this growth the SEB have made long term investments in centralised electricity production and associated transmission and distribution networks. These long term commitments may have formed an obstacle to cogeneration (and this situation continues) with energy end-users never really asking whether they could do better; this needs to be changed.

The important consequences of our more innovative (systemic) approach would be energy savings and improved security of supply for the Island (with parish energy service delivery). At any other level of delivery, in the horticultural/vinery sector for instance, it has been shown that the demand for electricity is low. In this instance an individual cogeneration end-user would not be able to match his complete heat demand with electricity and would be

forced to use only a small part of the possible energy savings. This is where a parish ESCo ensures a more optimal approach to energy service provision (see the discussion in Chapter 7).

Cogeneration needs a different sort of utility; a parish ESCo one that listens to the preferences of the demand side (as described by QQT). Where demand side marketing is a priority, instead of 'we have electrical energy, you can buy it'.

A parish ESCo that is market (QQT) orientated and not product (electricity etc) orientated, where serving the heat requirement is as important as serving the electricity requirement.

Yet to achieve all of this needs a complete turnaround of existing structures and attitudes. Only the States of Guernsey, playing an active role in stimulating this change through a strategic decision making centre (the SOGEMS) can make this happen.

At first sight, the energy market appears to have two distinct components; the management of energy supply and the management of energy consumption (see Section 11.6). Supply side management (through distributed cogeneration) needs to be determined (effectively imposed) by the States of Guernsey through the SOGEMS. Allowing demand side market mechanisms to operate, once the strategic energy

conservation 'distributed environment' has been created<sup>1</sup>.

Demand side management would then be directed at a dispersed parish set of energy end-users (households, enterprises etc) with supply side management directly influenced by the States of Guernsey (but the States of Guernsey are presently not organised to do this).

Such a change would allow individual end-users (who appreciate their own circumstances, are rational and know better than the States what their interests are) to continue to make their own decisions<sup>2</sup>. The consequences of this would be a significant reduction in prime fuel imports into the Island (as a first step).

The systemic approach is a reliable and effective way to intervene in the energy market for two reasons. The first is that it would work; the second is that it does not interfere in the decisions of a multitude of individual Island energy end-users.

A focus on Island strategic energy conservation is required, but to date it has not been easy to see how it could be implemented. The present work attempts to provide a solution to this problem and removes the conflict of interest between on the one hand organisations wishing to sell their 'prepared' fuels and on the other the Island's

1. Demand side energy conservation measures would then be the responsibility of the parish ESCo marketing department.
2. The States of Guernsey still setting Building Regulations, Health and Safety issues etc as part of the SOGEMS.

necessary requirement to reduce prime fuel imports<sup>1</sup>.

Guernsey shares at least two major characteristics with a number of other very small island communities:-

(1) It is an open economy and depends on both imports and exports in order to sustain its prosperity.

(2) It is currently (and has historically been) dominated by one sector because the small size of the economy constrains the degree of diversification (see Chapter 2).

It is a mis-interpretation of sensible free-market economics to suggest that the States of Guernsey has no role to play within the economy. Rather, within the energy sector, the States must provide the basic 'energy environment' and the private sector can then get on with what it does best, matching individual energy needs with energy services.

The establishment of a coherent Island (systems) framework (described in Resolution Level 1 of the soft systems model, Figure 19), amongst other things, would set a clear objective for energy conservation, and would put individual concerns in the broader context of strategic Island considerations.

The market can determine short-term priorities of consumption, but often works less well in dealing with

1. Present Island institutions are quite inappropriate for dealing with energy conservation and management.

long-term strategic judgements. Dealing with the long-term requires political pressures and tough strategic choices which no market mechanism is equipped to cope with. **Market mechanisms are an essential discipline but are no final substitute for political choice. Energy is too important to Guernsey to be left to market forces alone.**

Others have also published with this view (Fells and Lucas for example<sup>1</sup>), and suggested that the present U.K. government for example abandon its strict free-market approach to energy as irrelevant and damaging. Tombs<sup>2</sup> also has described:

"a bewildered U.K. government adopting short-term energy measures ill-adapted for long-term considerations"

Conscious management of the long-term development of the energy sector in the very small Island (Guernsey) context is an essential requirement.

Real energy planning has not to-date been addressed; intervention (through distributed cogeneration) may be the only way to fully release the Island's energy conservation potential. There is a strong case for the States of Guernsey to look at energy in a total systems sense (but this is not to say that the private sector does not have a role to play).

1. See Wyman, V, 2 July 1992, 'Power failure in the free market', for these references.

2. Tombs, P, January 1993, Electricity U.K..

## 10.2 ESCo accountability

A variety of forms of ESCo ownership could be considered (a) parish (b) States of Guernsey (c) co-operative (d) private or (e) contracted companies offering contract energy management packages (for example Cogeneration Systems Limited, see Section 7.6).

The present centralised approach to energy provision on Guernsey has historically had:-

- (a) an inability to be used for entrepreneurial type energy planning and
- (b) failed to consider various forms of ownership for energy service delivery.

If decisions can be left to the market place then that is what should be done<sup>1</sup>; others have suggested that "when the State owns, nobody owns; and when nobody owns, nobody cares"<sup>2</sup>. Regulated private monopoly is considered by many writers<sup>3</sup> to be superior to publicly owned monopoly.

A suitable way to provide these needed energy services may be to create energy service companies that market heat energy as well as electricity, but it may not really be Esco

1. Private ownership need not be an abdication of control, but an instrument of it via the SOGEMS.
2. Quoted in Putnam, Hayes and Bartlett, 4-5 September 91, 'Report on conference on reconstruction/privatisation', Moscow, pages 3-5.
3. See Vickers, J and Yarrow, G, 1988, 'Regulation of privatised firms in Britain' for example.



ownership that is all important but ESCo accountability.

The States of Guernsey have a responsibility to influence (or assist) the energy market place given the long-term nature of energy decisions. To the question "should energy strategy be led by markets or driven by governments, the answer is quite clear, it is both<sup>1</sup>" (governments influence markets anyway).

The goal of a sensible energy strategy should therefore be to blend market forces and States of Guernsey action so as to best achieve optimum use of imported energy resources (a systems approach encompasses both).

Government involvement is important for very small island communities such as Guernsey; oil imports into the Island are a critical commodity, the consumption of which cannot be suddenly reduced without major economic and social costs<sup>2</sup>. The States of Guernsey are therefore naturally concerned about security of energy supply to the Island.

It has long been recognised that, if markets are to work well, they must be suitably organised (frequently governments do play a role in such market organisation)<sup>3</sup>. When energy is looked at in a total systems sense (as

1. See Schlesinger, J, 1991, 'The ebb and flow of government intervention in oil markets'.

2. A sharp and unexpected rise in the oil price will also reduce the real income of the Island.

3. See Vickers, J and Yarrow, G, 1988, 'Regulation of privatised firms in Britain' for example.

advocated in the present work) it accommodates the set-up, the objectives, the resources and the necessary feedback at the all important Island level. Parish ESCOs would then be directly accountable to the SOGEMS (in the public sector) which would set the 'key stone' objective of strategic energy conservation<sup>1</sup>.

In contrast, the parish ESCOs, if in the private sector, would be evaluated from the shareholder's perspective (ie. they would tend to reflect the goals and objectives of the parish ESCOs on behalf of their shareholders). The way in which the Island can ensure that such private profit is controlled (and States objectives adhered to) is through some form of regulation<sup>2</sup> (regulation is in itself a sub-system within the SOGEM's soft system model). The system also needs monitoring/reviewing (a further sub-system of the soft systems model).

The extent to which regulation should occur is related in part to the 'cost of States of Guernsey financial support' which we discuss in Chapter 11. Energy subsidies should be used only to solve the problems the market cannot solve<sup>3</sup>; with subsidies possibly paid for out of the savings of the system (SOGEMS) for example.

1. Such a public owned system challenging and changing the culture from a centralised to a decentralised ethos.
2. It is necessary to control prices in markets where energy service delivery has a monopoly.
3. The introduction of Guernsey's non-economic renewables or electric vehicles for example.

Three groups are involved here:-

- (1) The regulator (with the task of setting and enforcing<sup>1</sup>).
- (2) The parish ESCo (the energy service company whose activities are regulated).
- (3) The energy end-users.

Each of which have different, often conflicting, objectives and interests. The regulator with important political objectives; the parish ESCo focussing on cost considerations and the energy end-user interested in security of supply and price stability.

Energy conservation on the Island cannot rely on the market alone to seriously promote it because:-

- (a) The present centralised approach on Guernsey is concerned with the expansion of 'prepared' fuel supplies; a formal SOGEMS approach would eliminate this culture.
- (b) End-users are reluctant to make cost-justified energy saving investments; regulated ESCos can be made to accommodate this objective<sup>2</sup>.

1. See Vickers, J and Yarrow, G, 1988, 'Privatisation: An economic analysis' provide theories of regulation.

2. Parish ESCos will accumulate capital through electricity and heat energy sales and would be well positioned to invest in end-user energy efficiency to households and enterprises. End-users possibly paying 'life-cycle cost bills' instead of electricity or heat energy bills, if they were to receive loans from the ESCo for energy efficiency investments for example.

(c) Markets are unable to meet the challenges of the possible use of currently uneconomic renewable sources for example<sup>1</sup>.

(d) Markets are unable to meet the challenges of poverty for example.

A tripartite partnership is required between the SOGEMS, ESCo and energy end-user, and backed up in the SOGEMS/ESCO and ESCo/end-user cases by legal contracts (see Chapter 8). The ESCo would offer its expertise and possibly sources of finance to deliver specifically agreed results. An intervention 'package' for each parish, with the contracts specifying who pays what and what is deliverable (see the Resolution Level 3 'Energy Planning' sub-system model in APPENDIX B).

The consequence of this will be that ESCOs will have the opportunity to shape local energy through entrepreneurial type planning (the present centralised approach does not have such influence) and will be required to offer advice to unique end-user needs (through QQT measurements for example).

### 10.3 Influencing role for parish energy users

Parish end-users should find it acceptable to live with distributed cogeneration in their 'backyard' because the energy 'hub' of each parish is usually an existing States of

1. No one will ever use an energy source which is perceived to be uneconomic within the existing economic paradigm.

Guernsey owned property (see Section 8.5). Each site is more than capable of accommodating all modular cogeneration plant, but the meaningful shift from centralisation to distributed cogeneration will largely be dependent upon strong support from each parish<sup>1</sup>. With a particular need to identify the local heating network with the immediate community.

An environmental disturbance study therefore needs to be carried out along the proposed route to ensure that the likely degree of disturbance is acceptable (pipe routes, position of services, results of trial excavations, soil tests etc). All of which means listening to what end-users want; a way of listening to end-users is to involve them directly in the energy planning process.

**Buildings and equipment do not determine energy use, people do.**

Parish energy end-users could and should participate in energy planning. Their grasp of energy issues as end-users (coupled with their knowledge of local conditions) need to be fully integrated into each parish ESCo's decision making

1. Apart from the good reasons for distributed cogeneration at the Island level, parish end-user participation also involves a large number of environmental, social and political choices.

process. Innovation is about the management of change<sup>1</sup>, the gatekeepers in this instance are the elected parish representatives.

Subjective issues such as the possible inclusion of a wind turbine into a parish cluster for example cannot simply be reduced to a numerical value alone; consultation is therefore an essential sub-system within our soft systems model. The complexity of the energy planning exercise should not present any serious obstacle to parishioners; the expertise would be derived from within the SOGEMS itself.

The consequences of this will be that more end-users will say 'yes' when they are convinced that development is undertaken in a sympathetic way (with maximum consultation in the early phases). With real opportunities for end-users to influence decisions (and real opportunities for significant energy import savings).

**Low income groups:**

Economic growth has not trickled down to the poor on the Island (even with rapid growth) and has not been

1. See for example Henry, J and Walker, D, 1991, 'Managing innovation' or

Burgelman, R.A and Maidique, 1988, 'Strategic management of technology and innovation' or

Loveridge, R and Pitt, M, 1990, 'The strategic management of technological innovation'.

sufficient to alleviate fuel poverty<sup>1</sup> (even on a wealthy Island such as Guernsey).

Evidence of fuel poverty can be exhibited in a number of ways:-

- (1) Energy inefficient dwellings (see Section 8.3).
- (2) Low levels of consumption (see Section 6.1).
- (3) A high proportion of household income spent on fuel.

Efforts to mitigate the impact of fuel poverty on the U.K. mainland for example, have concentrated on providing cash benefits through social security. Such benefits are not really effective in increasing energy conservation; a better way to help low income households may be to enable them to improve the efficiency of their use of energy by targeted conservation measures (parish ESCos can assist locally in this role).

Important is that one of the ways to address fuel poverty is to attempt to eliminate the present appalling centralised reject heat energy on the Island in the first place.

#### **End-user responses:**

It has been shown that end-users are responsive in changing their demand for energy when energy prices are

1. Fuel poverty can be defined as the inability to afford adequate heat and light.

See Boardman, B, 1992, 'Opportunities and constraints posed by fuel poverty on policies to reduce the greenhouse effect in Britain' for example.

changed (see Figure 42 for example). Parish end-users should therefore have a 'tariff setting' role.

Similarly, in relation to environmental concerns, the proposed construction of two further nuclear reactors at Flamanville on the French coast was the basis for a recent Channel Television phone-in vote<sup>1</sup>. Which posed the question:

"Should the Channel Islands object to further expansion of the nuclear industry on the nearby French coast ?".

Eight hundred and ninety five viewers voted 'yes', with one hundred and ninety three voting 'no'. Islanders are concerned for the environment and should similarly have a 'greening' role.

#### 10.4 The requirements of other States committees

A major role of the present Advisory and Finance Committee (as far as it affects other States departments) is to act as the States of Guernsey's 'co-ordinating committee'. 'Advisory' in the sense of ensuring that the work of the States is co-ordinated; ensuring co-ordination between States committees in formulation and implementation of policies. 'Financial' in the sense of submitting to the States, estimates of income and expenditure on both general revenue and capital account.

This is all conducted as an annual 'Island planning round' as shown in Figure 128. A 'profligate circle', where

1. See Guernsey Evening Press, 5 March 1993, 'Channel Television Phone-in'.



States committees put forward their annual policy and budgetary requirements as part of the round (prisoners of the usual way of doing things).

Important is that a distinction is made between so-called 'Trading Boards' and other States committees. At the present time the only contribution made to the States general revenue from Trading Boards<sup>1</sup> is from the Post Office (in respect of philatelic operations). Other Trading Boards such as the SEB make little contribution; their only obligation is to administer their services in as economical a fashion as possible (without subsidy<sup>2</sup>).

#### Advisory and Finance Annual Planning Round

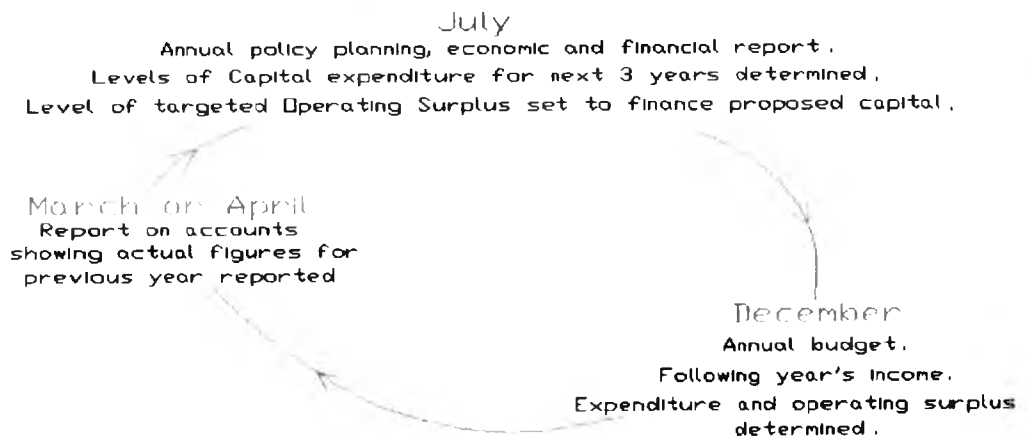

Figure 128

1. The 'Trading Boards' are committees of the States just like any other committee.
2. The trading undertakings could provide an annual contribution to general revenue by making payments in lieu of income tax or the payment of a 'dividend' of an agreed percentage on the capital employed, but neither has ever been applied.

In the Billet d'Etat of the XXII of the 29 November 1990 (amended on the 31 October 1991) the States adopted an Island 'Strategic and Corporate Plan'. The key strategic issues identified were (a) population (b) environment and (c) energy (areas of pressure group concern over recent years).

In relation to energy the Strategic and Corporate Plan stated that:

"the Island should be less dependent upon oil, as far as energy is concerned and that the Island should contribute in its own way to the more efficient use and management of energy, thus preserving natural energy reserves and reducing the emission of 'greenhouse' gases which are the cause of global warming".

The statement is worthy but the 'profligate circle' has not produced any reduction in primary fuel imports into the Island to date, and may well not be capable of doing so in the future.

The Plan went on to make the following statements with regard to policy areas largely making up the energy 'space':-

(1) Environment:

"the pollution of the Island's environment will be kept to the minimum necessary wherever this can be done reasonably and not at excessive cost".

(2) Transport, called for:

"an integrated transport and planning strategy for the

Island".

(3) Waste management:

"resolved to direct the Board of Administration to report to the States by the end of 1991 to enable the States to take an early decision on a long-term strategy for refuse disposal"

All such statements give a priority more rhetorical than real (see Section 1.5). The consequences of tackling the energy problem through a systemic methodology brings out the fact that it is also linked to the management of these other resources (an environmental strategy requires an energy strategy; energy and the environment for example stimulate transport policy etc).

If the Island's energy strategy is right other kinds of policy tend to fall into place too (all the more reason to have a good one).

#### 10.5 Regulatory interventions

Parish ESCOs would allow the efficient use of heat (which is currently a reject product from the centralised power station) but it could be argued that cogeneration linked with a heating network removes end-user choice. We will show that in very small densely populated island situations this loss of choice may be far outweighed by the reduction in primary energy imports (plus the other benefits which may accrue to an island such as Guernsey, with no indigenous energy resources, see Chapter 11).

As the development of parish heating networks are highly capital intensive, intervention by the States of Guernsey through the SOGEMS will be necessary in order to facilitate its market entry. The regulatory sub-system (see soft systems models in Figures 19 and 22) will influence the introduction of these necessary heating networks by each ESCo. This is where our soft systems modelling (Chapter 3) and our meta-modelling (Chapter 7) become 'real'. Regulatory provision being applied to facilitate the market entrance against competing fuel/heating in order to guarantee parish ESCos a sufficiently high end-user connection rate, to make their investments profitable.

The consequences of all of this would be to secure the reduction in primary energy imports described, with the regulator protecting the interests of:-

- (1) Parish ESCos (ie. ensuring all reasonable demands are met and that they are able to finance their activities etc).
- (2) Parish end-users (protecting the interests of end-users with respect to prices, quality of service etc).
- (3) Promote competition between ESCos (for example through the introduction of formal energy management contracts).
- (4) Take into account the interests of pressure groups.

The supply side regulatory interventions would be to:-

- (a) Decentralise the power and energy base to form parish ESCos; based upon the joint production of electricity and heat (the proposed location of each ESCo has already been

determined, see Section 8.5).

(b) Implement all potential, location specific, renewable (economic) sources within each parish ESCo (with the maximum consultation of end-users). Non-economic renewable sources possibly implemented by the introduction of a subsidy<sup>1</sup> (see Chapter 11).

**The demand side regulatory interventions would be to:-**

(a) Aim to achieve steady-state (smooth) electricity demand curves for each ESCo (see Section 9.6) to further improve supply side conversion efficiency.

(b) Stamp out the inefficient use of energy in all economic sectors of the Island economy.

Demand-side energy conservation comprises many various elements which include changes in behaviour; investment in new, more energy-efficient plant (retrofitting); modification of the production process or of the existing equipment, and so on. Important is the need for an emphasis

1. Such subsidies are not new to Guernsey. Horticulture for example, has had an interest subsidy scheme for capital investment. The scheme provides a subsidy on interest payable on 75% of the actual capital expended on a project over a period of up to seven years (see Guernsey Evening Press 22 July 1989).

In the year 1990/91 Guernsey growers took advantage of the 'capital support scheme' with proposals from 44 growers investing £3.9 million - Billet d'Etat XVI 1991, Item 2.70.

See Guernsey Evening Press, 22 July 1989, 'States cash backs grower investment' or

Guernsey Evening Press, 4 November 1988, 'Support grants could amount to £7.5 million in next six years'.

here on local suitability (through the parish ESCo); much of the investment in these demand side measures must come from the parish ESCo itself<sup>1</sup>.

A 'trade off' is required by the ESCo between investments directed towards improving demand side energy conservation (thereby reducing electricity and heat energy demands) and those aimed at providing cost competitive electricity and heat<sup>2</sup>. The parish ESCo needs to find the most cost-effective blend of energy and energy-saving equipment (ie. selling an energy 'package' to the end-user), but this is down to them to resolve.

Owen<sup>3</sup> has suggested that future improvements in demand side insulation standards may only marginally reduce the cost effectiveness of cogeneration/heating networks. If a cogeneration/heating network is cost effective when installed, improved insulation should not detract from the ability of the heating network to compete.

We can describe the demand side regulatory constraints

1. An ESCo should exist to invest in energy efficiency improvements on the demand side, not only to distribute or provide energy needs. See Boardman, B, February 1992, 'Why energy efficiency'. Who argues that much of demand side investment must come from utilities, and brings together some recent evidence to support a program of direct investment in the more efficient use of energy, particularly in homes.
2. However, factors such as the discount rate and assumptions on future fuel costs may be more important to densely populated (very small) island communities than demand side insulation levels for example; this is discussed in Chapter 11.
3. Owen, R.G, 1979, 'The effect of optimising the level of domestic thermal insulation on the economics of district heating'.

placed on ESCOs in three categories (1) pricing, (2) incentives and (3) regulations, as follows:-

(1) ESCo pricing

Traditionally energy prices can and have been set in relation to many different bases<sup>1</sup>, such as in relation to average historical costs or to marginal costs<sup>2</sup> for example (the choice of price base determines both the level and the structure of energy tariffs).

The traditional procedure has been essentially a long-term planning process, and starts with forecasting energy demand, which then leads to a development programme of plant to meet these forecasts (see Section 8.1). In spite of this, on the U.K. mainland over the last few years, more emphasis has been placed on ROI on energy projects, with typical regulatory control being of the R.P.I. - X% variety<sup>3</sup>.

With distributed energy planning, details on the level and pattern (QOT) of local energy demand (for various end-user types) provide much of the information needed to set soundly based prices.

1. See Webb, M.G, 1980, 'Energy pricing in the U.K.' for example.

2. See Schram, G, 1991, 'Marginal cost pricing revisited'.

The general theory of marginal cost pricing suggests that under perfect competition, setting prices equal to the marginal cost of production encourages economic efficiency (marginal cost tariffs usually consist of a demand charge, an energy charge and a standing charge).

3. See Beesley, M.E and Littlechild, S.C, 1989, 'The regulation of private monopolies in the United Kingdom' for example.

(2) ESCo incentives

Competition in the award of a formal energy management contract for operating a parish ESCo could be instituted, but important is that ESCos face significant financial disincentives if they are not allowed to recover the costs of implementing demand side energy conservation programmes and recover lost revenues. The regulatory sub-system therefore needs to ensure that promoting demand side energy conservation is in the best financial interests of ESCos (which requires further research effort).

(3) Regulations

The real demand side challenge really lies in uprating the existing stock of domestic dwellings (see Section 8.3). However, this may still not be completely achieved merely by the operation of market forces alone, and may need further regulatory intervention. Compulsory energy audits of domestic dwellings may be required, with a certificate showing that the house 'deems to satisfy' standards (mandatory roof/wall/floor insulation, double glazing etc).

Important is that the SOGEMS regulatory sub-system<sup>1</sup> should not interfere in the decision making process of commercial companies, except where matters of legitimate Island interest are concerned.

The consequences of all of these demand side activities will be to help further reduce prime fuel imports into the

1. Operating through the exercise of statutory powers.



Island (as the second step).

#### 10.6 Embedded cogeneration and the Island electricity network

An assessment of composite Island electricity reliability is complicated since it must consider the integrated effects of distributed cogeneration. The primary concern here is one of steady-state adequacy (ie. that distributed cogeneration is adequate to meet the electricity demands imposed on it<sup>1</sup>).

Even though there is complication, the potential impact of parish 'embedded cogeneration'<sup>2</sup> can be analysed by using a computer based specialist modelling tool named DINIS (DIstribution Network Information System) which has been developed by International Computers Limited (ICL) and used for electrical analysis purposes by the Writer within the SEB.

The old method of calculating the flow of electricity through a network was a time consuming business. Although computers handled the calculations, the skilled labour needed to prepare the input data (and to study voluminous outputs) was considerable.

The DINIS tool is an improvement on this and uses state of the art information technology which is designed to

1. See Allan, R and Billinton, R, 1992, 'Power system reliability and its assessment' for example.

2. Cogeneration plant located in a number of locations within an electricity network is known colloquially as 'embedded cogeneration'.

integrate an electricity authority's network drawings with electrical analysis facilities. It has been used by the Writer to conduct a number of Island electricity network studies and is used in the present work to compare the centralised power station at the Vale with an electrical analysis of the embedded cogeneration future<sup>1</sup>.

Many independent generators are now embedded in electrical networks elsewhere, which were previously designed for centralised generation<sup>2</sup>. Computer control and monitoring of a large number of widely distributed cogeneration units is a recent and most useful development.

When connecting embedded cogeneration to the existing Island electricity network, primary consideration must be given to the contribution that the newly installed plant will make to the fault level of the network. The safe operation of the network depends upon accurate prediction of these fault contributions (made by all of the plant operating in parallel) at the instant of a fault. DINIS indicates an approximate 11 kV fault level of 400 MVA with the centralised power station regime; with embedded cogeneration the fault level rises across the network and produces a maximum fault level of 450 MVA<sup>3</sup> (which may

1. The Island network modelled uses actual cable/transformer/ plant electrical data.
2. See Rogers, B, 1994, 'Control distribution networks with embedded generators' for example.
3. Other factors such as transient stability aspects are also important here.

require fault current limiting reactors to be fitted in the network, but this need not be prohibitive).

A load flow study with all embedded cogeneration, modelled with a maximum demand of 65 MWe (ie higher than the peak demand experienced on the Guernsey network to date) indicates that ONLY one 11 kV underground cable is overloaded within the St.Martin's ESCo. Which is located between the PE Hospital and Richmond substation (a length of 762 m), which needs uprating.

The present 11 kV electricity distribution network (without 33 kV transmission) therefore seems to be more than capable of handling the cogeneration penetration proposed. Figure 129 shows the present high voltage network on Guernsey (11kV and also 33 kV), and indicates the designated location of each ESCo's embedded cogeneration<sup>1</sup>.

#### **Electricity network reliability**

Even though energy services will be delivered at the parish level, it is preferable that one body has the role of co-ordinating the planning and operation of the Island electricity network as a whole<sup>2</sup>. It is not proposed that this body should act in any way as a market-maker with parish ESCos bidding into a pool (as instituted on the U.K.

1. This is not a 'geographic' map but merely an electrical 'schematic' representation of the network.

2. This need not necessarily be the case for heating networks.

mainland for example<sup>1</sup>). Very small island communities are too small an entity to consider such a notion.

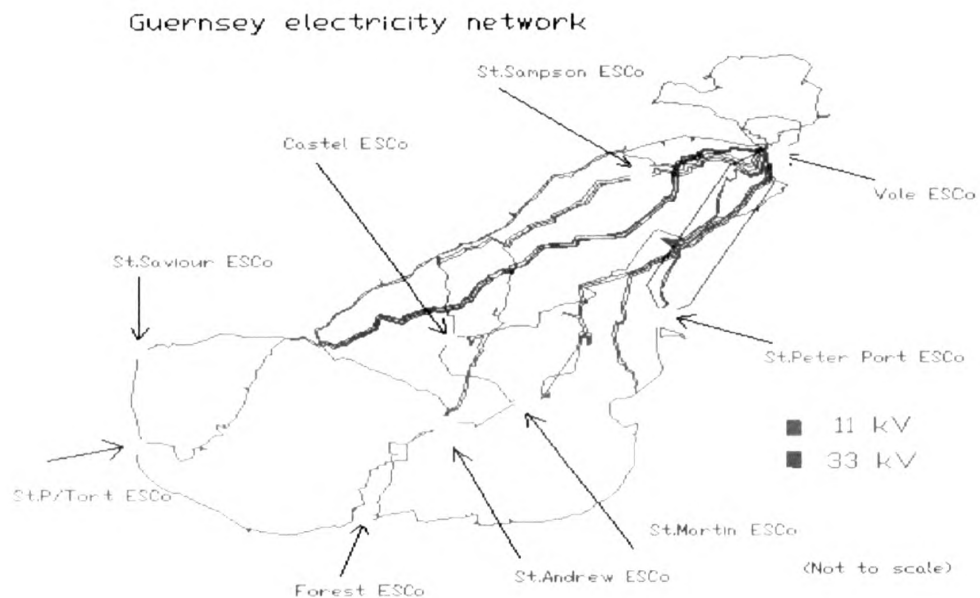

Figure 129

The so-called 'dispatching centre' would have three responsibilities:-

- (1) The development/maintenance of the Island electricity network.
- (2) Electricity network reliability.
- (3) The dispatch of parish cogeneration/renewable plant.

1. Interesting is that presently even in this situation over 80% of electricity purchase is still by contract; see Electric Power Engineers Journal, March 1994.

The centre would perform a variety of tasks relating to the reliability and dispatch of parish ESCo cogeneration/renewable sources. Ensuring that the demand and supply of electricity are balanced on a moment to moment basis (electricity cannot be stored). The primary concern again is one of steady-state adequacy (ie. whether the parish ESCo's electricity cogeneration sources are adequate to meet the electricity demands imposed on it). However, others have published with regard to such decentralised multi-machine power systems, such as Quali and Fantin<sup>1</sup> for example.

The centre could also develop and co-ordinate ESCo cogeneration/renewable maintenance schedules. Conduct studies and schedule ESCo plant so that contingency plans exist, to be immediately implemented if plant fails. The success of any contingency plan would require the availability of plant capacity (in some instances capacity which may NOT be located within the same parish ESCo).

The SEB currently operate a dual computer SCADA<sup>2</sup> system from a purpose built facility next to the centralised power station. This monitors Island electricity demand ONLY and communicates with central generation units and also distributed substations out in the parishes. This is currently referred to as the 'Energy Management Control Centre'.

1. Quali, A and Fantin, J, 1990, 'Optimal decentralised control for multi-machine power systems'.

2. Supervisory Control and Data Acquisition.

This would be very suitable as the 'dispatching centre', tracking and adjusting cogeneration at the distributed parish level. Then becoming a true 'Energy Management Control Centre' (energy in the true sense, not just merely electricity provision<sup>1</sup>).

The consequences of distributed cogeneration would then result in the reduction of spinning reserve<sup>2</sup> and hot-standby<sup>3</sup>, which are required to cope with surges in demand. Reliability would also be increased; if the output from the present centralised power station is lost it is equivalent to losing ALL parish cogeneration plant (centralisation of plant thus represents a much higher risk). We will show that this greater unreliability is achieved at a significant cost in terms of centralised

1. See Bantelmann, H, Kochs, H.D and Zimmer, H, August 1990, 'The design of a modern total-energy control centre' for an example of this.

2. Sources of inherent reserve include spinning reserve (ie. the spare capacity on generating sources which are running at reduced output) and inertia in rotating plant. Such reserve is wasteful in terms of wasted fuel (due to greatly reduced conversion efficiency at 'part load' operation for generation plant).

The present centralised power station (with large slow-speed diesels) are inflexible in this respect. The SEB sometimes running the whole Island electricity network from a single slow-speed machine, accepting the risk of an Island blackout if it should fail.

3. Electricity generation plant that may need to be provided to protect the network against failure of plant or in case demand is underestimated. Distributed cogeneration would be allocated to the electrical network as a whole, not to back up any particular parish ESCo.

In the absence of such generation reserve, load shedding and voltage reductions are options which can also be taken.

energy, capital and manpower (see Chapter 11).

In contrast, smaller cogeneration units can be added incrementally; diversity of supply thus effectively equating to a distributed number of small cogeneration stations, providing flexibility of response.

#### **Electricity network losses**

We now turn to the important impact of embedded cogeneration on electricity network losses.

The centralised Island electricity network can be divided into three hierarchical levels:-

Level 1	Centralised generation
Level 2	Transmission facilities
Level 3	Distribution facilities

In contrast, distributed cogeneration needs only two hierarchical levels:-

Level 1	Parish cogeneration
Level 2	Distribution facilities

Distributed cogeneration eliminates transmission losses and the need for the existing 33kV high voltage transmission network on Guernsey<sup>1</sup>.

Transmission losses have an adverse effect on the economics of central generation in two ways. Not only do

1. Distributed cogeneration ensures that short distances occur between electricity/heat source and electricity/heat demand.

these losses increase the running costs of central generation, they also increase the capital costs because of the extra centralised capacity required to overcome losses at periods of peak demand.

In 1991/92 the SEB generated 243,583 GWhe and the units sent out from the central power station was 233,782 GWhe. Thus the works power used within the power station was 9,801 GWhe (4.02%). The units billed was 216,861 GWhe, which gives an energy loss<sup>1</sup> on the transmission and distribution network of 16,921 GWhe (7.2%); neglecting non-technical losses (eg. theft).

With the aid of DINIS we can determine the energy loss of the H.V. network with centralised generation, which is 3.3% (L.V. losses are therefore 3.9%). With embedded cogeneration (and no 33kV H.V. network) the loss on the H.V. network drops to 1.4%, which represents a saving in energy losses of 1.9%.

Important though are not only energy losses (GWhe) but also power losses (MWe) during peak periods (but the latter are usually not considered<sup>2</sup>). The demand or MWe component is

1. There are two separate types of electrical losses (1) the copper or variable losses which vary with the square of the current and peak heavily at peak time and (2) the iron or fixed losses which are voltage related and vary approximately with the square of the voltage.
2. The SEB favour the costing of only the energy component of losses. This approach however is unrealistic because losses occupy network capacity and impact on generation requirements (by altering capacity).

See Tobin, M.P. and Glynn, B. 1991, 'Distribution system losses are evaluated by measurement' for a discussion of demand loss



a measure of the capacity or resources occupied by the losses and in the Guernsey context we will show that these are far more severe in demand terms.

The accuracy and usefulness of loss studies are directly dependent upon the quality of basic load data over a specified time period. For the purposes of our analysis we again take the highest SEB peak day load profile of 7 February 1991 (see Section 7.7), FIGURE 130.

States of Guernsey Electricity Board  
(peak day - 7 February 1991)

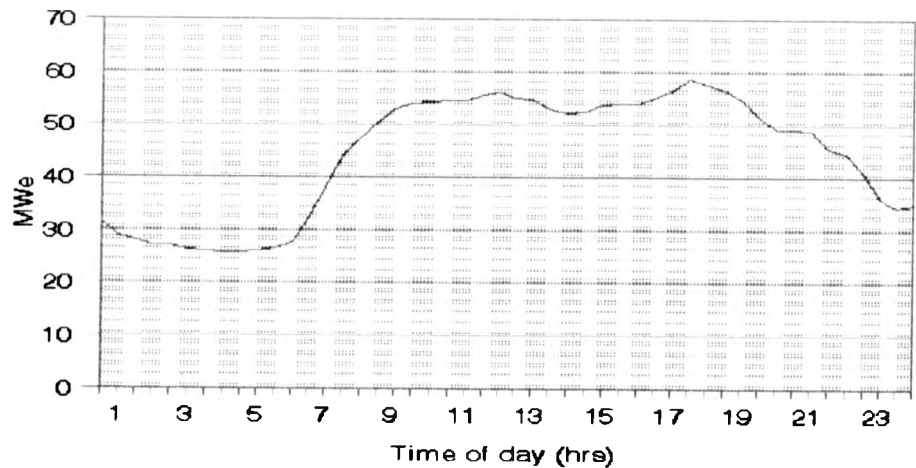

Figure 130

Electrical energy losses are a function of the square of the load current ( $I^2R$ ), and are directly related to the square of the demands. TABLE 10.1 details the hourly

...Continued...

at peak.

loads over the 24 hour period and TABLE 10.2 provides a load duration and loss table for the peak day (load duration is the relationship of demands and the duration of the demands over a specified time period).

Energy loss can be divided among the 24 hourly loads in proportion to the squares of the demands; the peak hour would therefore become responsible for:-

$$\text{Peak hour loss} = [3457/53158] * 100 = 6.5 \text{ MWe}$$

$$\text{Peak demand loss} = [6.5/58.8] * 100 = 11.05\%$$

TABLE 10.1 - Hourly loads over the SEB 24 hour peak day

Morning	Demand (MWe)	D <sup>2</sup>	Aft./Even.	Demand (MWe)	D <sup>2</sup>
12 am - 1 am	31.5	992	12 pm - 1 pm	55.0	3025
1 am - 2 am	28.0	784	1 pm - 2 pm	52.0	2704
2 am - 3 am	27.0	729	2 pm - 3 pm	54.0	2916
3 am - 4 am	26.5	702	3 pm - 4 pm	55.0	3025
4 am - 5 am	27.0	729	4 pm - 5 pm	58.0	3364
5 am - 6 am	32.0	1024	5 pm - 6 pm	58.8	3457
6 am - 7 am	43.5	1892	6 pm - 7 pm	56.5	3192
7 am - 8 am	50.0	2500	7 pm - 8 pm	51.5	2652
8 am - 9 am	54.0	2916	8 pm - 9 pm	48.5	2352
9 am - 10 am	55.0	3025	9 pm - 10 pm	45.0	2025
10 am - 11 am	56.5	3192	10 pm - 11 pm	40.0	1600
11 am - 12 pm	56.0	3136	11 pm - 12 pm	35.0	1225
		-----			-----
		21621			31537

[Total D<sup>2</sup> = 53158]

**TABLE 10.2 - Load duration and loss table**

<b>Demand (MWe)</b>	<b>Freq.</b>	<b>Cumul. freq.</b>	<b>Percent of peak</b>	<b>Percent Duration</b>	<b>Squares of demand</b>	<b>Loss Table (MWe)</b>
58.8	1	1	100.0	4.2	3457	6.5
58.0	1	2	98.6	8.3	3364	6.3
56.5	2	4	96.1	16.7	3192	6.0
56.0	1	5	95.2	20.8	3136	5.9
55.0	3	8	93.5	33.3	3025	5.7
54.0	2	10	91.8	41.7	2916	5.5
52.0	1	11	88.4	45.8	2704	5.1
51.5	1	12	87.6	50.0	2652	5.0
50.0	1	13	85.0	54.2	2500	4.7
48.5	1	14	82.5	58.3	2352	4.4
45.0	1	15	76.5	62.5	2025	3.8
43.5	1	16	74.0	66.7	1892	3.6
40.0	1	17	68.0	70.8	1600	3.0
35.0	1	18	59.5	75.0	1225	2.3
32.0	1	19	54.4	79.2	1024	1.9
31.5	1	20	53.6	83.3	992	1.9
28.0	1	21	47.6	87.5	784	1.5
27.0	2	23	45.9	95.8	729	1.4
26.5	1	24	45.1	100.0	702	1.3

**Frequency** = Number of hours of occurrence for each demand.

**Cumulative frequency** = Summation of frequencies from  
previous column.

**Percent of peak** = [Demand (MWe)/Peak (MWe)] \* 100

**Percent duration** = [Equal/exceed/Specified time] \* 100

**Square of demands** = Demand<sup>2</sup> \* Frequency

Transmission/distribution losses thus require 6.5 MWe of network capacity, which is equivalent to 11.05% of net centralised generation. Over 11% of the centralised power network capacity (ie. centralised generation, transmission and distribution) is required to supply the demand loss at peak (see also Section 7.7)

In relative terms, such losses are equivalent to over half the output of one of the large Sulzer slow-speed diesel generators at the central power station. Important is also the cost of the network capacity occupied by these losses (the demand component).

This extra capacity can be seen to be considerable since it is determined by the peak demands. The estimated benefits of using embedded cogeneration are therefore significantly enhanced if full allowance is made for the effects of these losses. Capital cost savings are estimated to be £8 million<sup>1</sup> (1992 prices), equivalent to 40% of the SEB's turnover in 1991/92 for example.

Under-valuing such demand losses on the centralised Island power network diverts investment towards the generation and transmission network levels, something which has certainly occurred on Guernsey. This has led to non-optimal electricity network development overall, and wastes resources. In contrast, the consequences of embedded cogeneration (injecting directly into the middle of the

1. Equivalent to half the cost of a new slow-speed diesel (See Appendix H).

power network) results in a significant reduction in these energy and demand losses<sup>1</sup>.

Reliability, security of operation and maintenance should not be reduced by a change from centralised generation to distributed cogeneration. Reliability and security of operation may in fact be enhanced, with maintenance and servicing of local facilities carried out by each ESCo themselves.

#### SUMMARY

- (1) At the 'Island level' a true sense of energy priority can be achieved.
- (2) A complete turnaround of existing structures and attitudes is required, with distributed cogeneration determined (effectively imposed) by the States of Guernsey through the SOGEMS.
- (3) The States must provide the basic 'distributed environment' and the private sector can then get on with what it does best, matching individual energy needs with energy services. Market mechanisms are an essential discipline but are no substitute for political choice.
- (4) Energy is too important to Guernsey to be left to market forces alone. Conscious management of the long-term development of the energy sector is an essential

1. See Summerton, J and Bradshaw, T.K, 1991, 'Towards a dispersed electrical system' for example.

requirement.

(5) What is important is not primarily ESCo ownership but ESCo accountability.

(6) A tripartite partnership between the SOGEMS, ESCo and energy end-users is required, and backed up in the SOGEMS/ ESCo and ESCo/end-user cases by legal contracts. The ESCo would offer its expertise and possibly sources of finance to deliver specifically agreed results. An intervention 'package' is required for each parish, with the contracts specifying who pays what and what is deliverable (see the Resolution Level 3 'Energy Planning' sub-system model in APPENDIX B).

(7) When energy is looked at in a total systems sense it accommodates the set-up, the objectives, the resources and the necessary feedback at the all-important Island level.

(8) Innovation is about the management of change, the gatekeepers in this instance are the elected parish representatives.

(9) Parish end-users should have a 'tariff setting' and 'greening' role.

(10) The present States planning round is more of a 'profligate circle', with Trading Boards (such as the SEB) sitting on the periphery. States committees putting forward their policy and budgetary requirements as part of the round (prisoners of the usual way of doing things).

(11) If the Island's energy strategy is right other kinds of policy tend to fall into place too.

(12) Much of the investment in demand side measures must come from the parish ESCo itself, with energy end-users possibly paying for energy-saving services through their bills. The parish ESCo would have responsibility for identifying the most cost-effective blend of energy and energy-saving equipment.

(13) The present electricity distribution network seems to be more than capable of handling the cogeneration penetration proposed, with little uprating of existing cable/transformer/plant required.

(14) Even though energy services would be delivered at the parish level, it is preferable that one body has the role of co-ordinating the planning and operation of the Island electricity network as a whole (this need not necessarily be the case for heating networks, but co-ordination and consultation are essential).

(15) The consequences of distributed cogeneration would result in the reduction of spinning reserve, hot-standby and in increased reliability. Diversity of supply effectively equating to a distributed number of small cogeneration stations providing flexibility of response.

(16) Embedded cogeneration results in an energy loss reduction on the electricity network of 1.9% and a centralised generation capacity saving of 6.5 MWe (some £8

million capital saving at 1992 prices).

(17) Reliability, security of operation and maintenance should not be reduced by a change from centralised generation to distributed cogeneration. Reliability and security of operation may in fact be enhanced, with maintenance and servicing of local facilities carried out by each ESCo themselves.



## CHAPTER 11

### THE COSTS OF CHANGING THE SYSTEM

The kind of system changes discussed will require capital investment in the transfer from centralisation to decentralisation. With the transition achieved by a phased (parish) programme of investments, with no further expansion of the centralised power station site at the Vale. When existing Vale slow-speed diesels are retired, they would not be replaced. When a new tranche of generating capacity is required, it would be replaced with distributed cogeneration.

All this will involve detailed cost considerations, which is the subject of this penultimate Chapter. It considers whether the unit costs (kWhe and kWht) of distributed cogeneration are competitive with the present centralised approach (and also with renewable methods).

It leads to the conclusion that distributed cogeneration sources (NOT central generation sources) satisfy the requirement of maximising NPV, and provide greater security against movements in interest rates and also fuel prices. In terms of renewable energy sources, only landfill gas makes any economic contribution.

#### 11.1 The costs of serving each parish<sup>1</sup>

Currently the SEB do not differentiate their costs according to location but rather differentiate them

1. All costs are estimated in 1992 values.

according to customer classification. A parish that is particularly costly to serve is not readily identifiable as such because the SEB tend to average their costs over the entire pool of end-users.

It is important to get closer to the true cost of serving each parish, and we will show that whether distributed cogeneration is cost-effective or not will largely depend upon its geographic location.

A parish that is particularly costly to serve (and hence a good candidate for distributed cogeneration) is readily identifiable as such by how far it is located from Vale (ie. the location of the centralised power station). Since the power station is in the far north of the Island anyway, ALL parishes appear to be good candidates.

TABLE 11.1 provides a pre-tax evaluation of each ESCO's distributed cogeneration sources (ALL positive NPVs), derived from our financial and energy analysis work within each parish model (see Chapter 7; life of plant 10 years, discount rate 15% etc). 'Scenario 1' is with the price of heat set to zero<sup>1</sup>. 'Scenario 2' is with the price of heat set to the comparable oil fired central heating equivalent (all heat energy is assumed sold).

1. The electricity sold by each parish ESCO is priced the same as that levied by the SEB (9.37p/kWh, see TABLE 4.9).

Pre-tax evaluation of distributed cogeneration

Scenario 1

ESCo	MHe	Load Factor	** Capital emp (£)	NPV (£)	Annual Gas Oil (Litres)
Vale	9.870	.299	2320000	5701955	11210425
St. Sampson	8.935	.338	2220000	2934952	7650459
Castel	7.100	.355	1880000	1863261	5719479
St. Saviours	1.950	.454	730800	579871	2047051
St. P./Torveval	3.600	.282	1006800	453966	2399257
Forest	1.885	.438	819700	336031	1912419
St. Andrews	1.950	.526	730800	542284	2001182
St. Martin	7.085	.339	1755000	2068410	5740731
St. P. Port	21.800	.433	6220000	8992742	22374229
	64.175		17683100	23473472	61055232 *

Scenario 2

ESCo	MHe	Load Factor	** Capital emp (£)	NPV (£)	Annual Gas Oil (Litres)
Vale	9.870	.299	2320000	11176014	11210425
St. Sampson	8.935	.338	2220000	6670879	7650459
Castel	7.100	.355	1880000	4856088	5719479
St. Saviours	1.950	.454	730800	1579447	2047051
St. P./Torveval	3.600	.282	1006800	1625525	2399257
Forest	1.885	.438	819700	1269867	1912419
St. Andrews	1.950	.526	730800	1519463	2001182
St. Martin	7.085	.339	1755000	4871614	5740731
St. P. Port	21.800	.433	6220000	19918095	22374229
	64.175		17683100	53286792	61055232 *

\* - this compares well with the present imports of HFO/GO for electricity production (see Figure 30)  
 \*\* - See APPENDIX H

TABLE 11.1

In order for the use of waste heat to prove attractive the price should be the same or lower than the cost of generating heat from alternative sources. We therefore use the cost of heat from an oil fired boiler as a comparison<sup>1</sup> (no alteration to the price of electricity).

A simple assessment of pay-back period<sup>2</sup>, based on initial capital costs of all ESCo distributed cogeneration sources, indicates a maximum pay-back period of 2 years (with no heating network costs included, and all heat energy assumed sold).

Regardless, for distributed cogeneration to be successful two important conditions must be satisfied:-

- (1) There must be a demand for the heat output within each parish.
- (2) Its unit costs (kWhe and kWht) must be competitive with the present centralised approach (and also with renewable methods).

We have already shown in Chapter 9 that there IS a demand for waste heat out there in the parishes. We now go on to compare the costs of distributed cogeneration with the centralised approach, and also location specific renewable

1. 1.48p/kWh, see TABLE 4.9 (the cost of heat generated, using a notional boiler efficiency of 80%, is 1.85p/kWht).
2. This method is both the least sophisticated theoretically and the most commonly used, though its use is often only as a first screening device. It measures the number of years that the project will take to recover its initial outlay from its net cash flows.

methods available on Guernsey (see Section 8.2).

### 11.2 Competing options

Discounted cash flow is again used to describe the interaction between capital expenditure and the resulting fuel (and money) savings achieved.

#### The centralised approach

The SEB centralised unit cost of generation is given as 2.705 p/kWhe (see TABLE 4.8), but great care needs to be exercised when making comparisons with this and the costs of alternative generation<sup>1</sup>. This SEB figure enjoys the benefit of substantial written down capital investment.

A more appropriate comparison is to compare the cost of a NEW centralised slow-speed diesel with the alternative methods of generation, which are also NEW.

If a new centralised slow-speed engine could be employed for a nominal 80% of the hours in each year and achieve an average load during running hours of 75%, its annual sent out electrical energy would be 73,584 MWhe. Using this and a capital investment for a slow-speed diesel of £16 million (1992 prices, see Appendix H) produces a

1. See Thomson, L, May 1993, 'Reporting changes in the electricity supply industry and privatisation'. The accounting treatment of fixed assets can have a significant impact on profits (through the depreciation charge), on net assets, and thus on the rate of return.

centralised unit cost of generation of 4.8 p/kWhe<sup>1</sup>, which is a far more realistic figure.

We therefore take central energy source costs to be 4.8 p/kWhe for electricity (the NPV is + £857,379; the simple payback 5 years) and 1.85 p/kWht for heat.

### Location specific renewable methods

#### Wind energy costings

The design of wind energy projects are now reaching sufficient maturity to be able to give reliable cost estimates. The costs used in the present work relate to the wind generation facility at Delabole in Cornwall<sup>2</sup>. A facility which the SEB visited in March 1993 and accurate (actual) costings obtained (1992 prices).

The principle financial data for a 300 kW wind turbine (as proposed for Guernsey) would be as follows:-

Capital cost	£300000 <sup>3</sup> (£1000/kWe installed)
Annual O & M cost	£6000 (2% of total investment)
Expected <sup>4</sup> annual kWhe sent out	273000 min (see Section 9.3)

1. Important, using a HFO fuel cost of 7 p/Litre, an O & M cost of 0.98 p/kWhe and the improved conversion efficiency of 40% for a slow-speed diesel (NOT 35%, which is the case of distributed cogeneration).
2. For a description of the Delabole facility see Edwards, P.D and Milborrow, D.J, October 1992, 'Delabole wind farm'.
3. No land costs are included. The land based capital cost is used here (but the proposed locations are parish islets).
4. As evaluated by Monte-Carlo simulation.

Income from electricity £25580<sup>1</sup>

(Wind energy will NOT breakeven<sup>2</sup>)

#### Refuse burning costings (St.Sampson)

St.Sampsons is a large user of heat energy and is a suitable location for a refuse burning plant, which offers the advantage of a 'negative' fuel cost (ie. a fuel that you are paid to take<sup>3</sup>).

There are several ways that rubbish can be turned into useful heat, which differ in three key areas:-

- (1) How the incoming refuse is sorted and processed (if at all).
- (2) How it is burned.
- (3) How the emissions the incineration produces are cleaned.

Whether there is a need to process the waste before burning depends on the combustion process used, with combustors available in two main forms:-

- (1) High temperature, mass-burn grate incinerators (which accepts the refuse as it arrives at the plant, with little or no pre-processing).
- (2) Circulating fluidised bed incinerators (which require non-combustible materials to be removed, before the waste is

1. Using the average SEB price of 9.37p/kWh (see TABLE 4.9).
- 2: The environmental costs of turbogenerators are not included.
3. Wastes which seem to be an inevitable consequence of the affluent Guernsey lifestyle.

fed to the bed).

The heat produced by combustion of the waste is then removed from the flue gas in order for the gas to be cleansed, before discharge to atmosphere. The heat abstracted can then used as a direct heat source (hot water) for the provision of heat to the St.Sampson's heating network for example.

Refuse incinerators operate most efficiently on a continuous basis (ie. three shift manning is required) with the heat produced at night and stored for use later. The costings used in the present work relate to such continuous operation and are estimates produced by Ewbank Preece<sup>1</sup> for the SEB in 1989, which allows for refuse incineration of 70000 tonnes/annum, using the mass-burn grate technique.

The costings relate to a single-grate stoker (standard design) incinerator type VKW MG 40, manufactured by Keller and Peikert<sup>2</sup>

The principle financial data (1992 prices<sup>3</sup>) for a refuse incinerator plant of 70000 t/annum capacity (as proposed for Guernsey) would be as follows:-

Capital cost	£5580000 <sup>4</sup>
--------------	-----------------------

1. Ewbank Preece Limited, 1989, 'Review of generation development'.
2. A scaled down version of the Edmonton incineration plant, London.
- 3: 1989 Ewbank Preece estimates are increased using the Guernsey RPI index from June 1989 to June 1992.
4. No land costs are included.



Annual maintenance cost	£111600 (2% of total investment)
Annual operational cost	£436260 (staff/aux.power etc)
Annual kWh <sub>t</sub> sent out	91048000 min (see Section 9.3)
Income from heat	£1684388 <sup>1</sup>

(The simple payback for this installation is of the order of 10 years<sup>2</sup>)

#### Anaerobic (sewage) digestion costings (St.Peter Port)

It would be good ecologically to end the practice in Guernsey of allowing sewage to run out to sea, and for the Island to recycle its sewage products<sup>3</sup>.

In the last twenty years anaerobic digestion has been used (with the help of new technology) at medium to small sewage works, and may be suitable for Guernsey. This new technology uses improved stirring efficiency, better insulation properties and improved process design and control.

As well as providing a biogas for electricity production, the process can also provide a stable sludge for

1. Neglecting the price paid to the St.Sampson's ESCo for 'taking' the refuse. Also neglecting heat losses.

Using 1.48p/kWh prime fuel (see TABLE 4.9); the cost of heat generated 1.85p/kWh<sub>t</sub> (using a boiler efficiency of 80%).

2. This is a positive solution to Guernsey's landfill problem (refuse burning redirects refuse away from future landfill sites, but the financial benefits of this are not included; see 'Further Work' discussion in Chapter 12).

3. See Fletcher, P.G, Guernsey Evening Press, 18 April 1992, 'Green up lungs of the corridor' or

Arendt, P, Guernsey Evening Press, 6 March 1991, 'Start saving for a sewage plant plea'.

long-term storage (for later use as a fertiliser) without any further treatment or conditioning.

The principle financial data (provided by Mass Energy Limited; 1992 prices) to auto desludge, thicken, digest and store would be as follows:-

Capital cost	£850000 <sup>1</sup>
Annual O & M cost	£17000 (2% of total investment)
Annual kWhe sent out	631000 min (see Section 9.3)
Income from electricity	£59125 <sup>2</sup>

(Anaerobic digestion will NOT breakeven<sup>3</sup>)

#### Landfill (gas) costings (Vale)

Gas produced in a landfill site may be abstracted using vertical well technology, often years after initial gas production has begun. The gas delivered to spark-ignition gas engines is usually operated under closed-loop fuelling control to maintain optimal operating conditions (despite the variable nature of the fuel).

The principle financial data (provided by O'Brian Energy Europe Limited; 1992 prices) for the landfill site at Bordeaux would be as follows:-

1. No land costs are included.
2. Using the average SEB price of 9.37p/kWhe (see TABLE 4.9). Neglecting sales of digested sludge liquor to the growing industry (as a nutrient rich fertiliser) for example.
- 3: This again is a positive solution to Guernsey's environmental problems caused by the disposal of raw sewage (but the financial benefits are not included; see 'Further Work' discussion in Chapter 12).

Capital cost	£317200 <sup>1</sup>
Annual O & M cost	£6344 (2% of total investment)
Annual kWh sent out	3255917 min (see Section 9.3)
Income from electricity	£305079
Income from heat	£84328

(The simple payback for this installation is of the order of 1 year<sup>2</sup>)

Over a life of ten years wind energy, refuse burning and anaerobic (sewage) digestion have negative NPVs ( - £352,300, - £2,677,000 and - £1,065,000 respectively). These figures are not optimistic, and are at variance with popular opinion on Guernsey. For landfill (gas)<sup>3</sup> the NPV is + £1,446,110.

The NPV method therefore indicates that distributed cogeneration sources (see Scenario 2 of TABLE 11.1) and landfill (gas) may make a much larger economic 'contribution' than the present centralised (slow-speed diesel) approach.

1. Excluding the gas collection system, as this is already in place.

No land costs are included.

2. This again is a solution to Guernsey's environmental problems with the landfill site at Bordeaux (but again the financial benefits of this are not included; see 'Further Work' discussion in Chapter 12).

3. Landfill (gas) will reduce fuel imports into the Island by 15 GW (1.2% with the implementation of distributed cogeneration, see TABLE 9.10).

### Comparison of unit costs

TABLE 11.2 now provides a comparison of the unit costs of distributed cogeneration and renewable options, when producing one unit of electricity and/or heat. The economic life of each alternative is assumed to be the same (ten years), as a necessary simplification<sup>1</sup>.

**TABLE 11.2 - Comparison of the costs of distributed cogeneration and renewable options, when providing one unit of electricity and/or heat**

	pence/kWhe	pence/kWh <sup>t</sup>
Distributed cogeneration <sup>2</sup>	5.5 to 6.1 <sup>3</sup>	3.9 to 4.3 <sup>4</sup>
Wind	13.19	
Refuse burning		1.22
Anaerobic (sewage) digestion <sup>5</sup>	16.17	
Landfill (gas)	1.17 <sup>6</sup>	0.84 <sup>7</sup>

The DCF for wind generation is provided in Figure 131 as an example of the technique<sup>8</sup>.

1. Any significant differences in life-cycle of the capital equipment will necessarily lead to a more subtle distinction between technological variants (see 'Further Work' discussion in Chapter 12).
2. From parish models (see Chapter 7).
3. Electricity only (no heat sales).
4. Heat only (no electricity sales).
5. Includes long term storage of sludge but no sales.
6. Electricity only (no heat sales).
7. Heat only (no electricity sales).
8. The cost of generation using a wind turbine on Guernsey is considerably more than distributed cogeneration, at present fuel prices.

WIND DISCOUNTED CASHFLOW											
Electricity price adjustment 1											
Electricity unit cost .0937 £/kWh (1992)											
Annual kWh 273000											
	1992	1993	1994	1995	1996	1997	1998	1999	2000	2001	2002
Energy cost	0	0	0	0	0	0	0	0	0	0	0
O & M cost	-6000	-6000	-6000	-6000	-6000	-6000	-6000	-6000	-6000	-6000	-6000
Capital repayment	-30000	-30000	-30000	-30000	-30000	-30000	-30000	-30000	-30000	-30000	-30000
Electricity revenue	25580	25580	25580	25580	25580	25580	25580	25580	25580	25580	25580
Ann.cashf	-300000	-10420	-10420	-10420	-10420	-10420	-10420	-10420	-10420	-10420	-10420
D.factor	1.0000	.8696	.7561	.6575	.5718	.4972	.4323	.3759	.3269	.2843	.2472
D.cashflo	-300000	-9061	-7879	-6951	-5958	-5181	-4505	-3917	-3406	-2962	-2576
NET PRESENT VALUE (£'000)											
The cost of generating one unit of electricity by wind power							.1319	pence			
Total capital cost (1992):											
Principal 300000											

Figure 131 Discounted cashflow for wind generation

With the present centralised approach, the ratio between electricity and heat energy prices in the final user market is 5 (9.37p/1.85p). The cost of the combined product from parish distributed cogeneration sources (using this same ratio) varies from 4.3 to 4.8 pence/kWhe for electricity and 0.86 to 0.96 pence/kWht for heat energy, TABLE 11.3 (the effect of price changes on demand are neglected).

TABLE 11.3 - Cost of the combined product from distributed cogeneration sources

Parish	pence/kWhe	pence/kWht
Vale	4.3	0.86
St.Sampsons	4.5	0.89
Castel	4.6	0.92
St.Saviours	4.7	0.93
St.P/Tort	4.8	0.95
Forest	4.8	0.96
St.Andrews	4.7	0.93
St.Martins	4.6	0.91
St.Peter Port	4.5	0.89

The cost of the distributed cogeneration combined product (electricity and now heat energy) is therefore comparable with that of centralised generation (4.8 p/kWhe and 1.85 p/kWht) and competitive with it. But now with potential prime fuel import savings of some 23% (see Chapter 9).

These complex and detailed considerations (involving the high capital cost of centralised power generation against the savings which may arise mainly from the reduced use of fuel with distributed cogeneration) have not been addressed on Guernsey before. The research data involved has

hitherto not been so readily available.

#### Cash flow sensitivity

All of the generation/cogeneration prices are influenced by (a) economic life (b) discount rate and (c) the cost of fuel changes. The cost competitiveness of these alternatives is particularly affected by the discount rate and the price of imported petroleum into the Island.

In Section 7.5 the discount rate was mainly considered to be a chosen target rate of 'cost of capital', but it can also be regarded as a 'target rate of return'.

Decisions on discount rates can be made within two contexts:-

- (1) 'Private' decisions (parish ESCOs for example).
- (2) 'Public' decisions (reflecting decisions in which we act with responsibility for fellow Islanders and for future generations; within the SOGEMS for example).

Market discount rates reflect the former context, whereas the latter reflects a more social discount rate.

A high rate REDUCES the overall level of investment (and the greater discrimination against future generations). A lower rate ENCOURAGES investment and increases the demand for resources.

The rate of discount relevant to the SOGEMS investment criteria may therefore not be the same as the ESCO discount rate and, since high rates discriminate against future

generations, we might expect the SOGEMS discount rate to be lower than the ESCo discount rate.

A lowering of rates across the board however, could have counter-productive results if the aim is to accommodate environmental concerns for example. An alternative may be to lower discount rates for 'environmental' projects but not for other projects; but the question as to which is an environmental project and which is not is difficult to assess.

The choice of the discount rate also has a particular effect on the rate of exploitation of natural resources. The basic decision with regard to such resources is how much to consume now and how much to hold in store for future consumption. The argument again is one of price of present versus future consumption (ie. the discount rate).

Calculating the appropriate rate therefore is extremely difficult; a complex debate which we do not review here, but for further study see Lind et al<sup>1</sup> for example.

When calculating, in money terms, there is therefore a tendency to wrongly value capital and fuel; overvaluing capital (ie. using too high a discount rate) and undervaluing fuel. In the present work, these two parameters

1. Lind, R.C et al, 1982, 'Discounting for time and risk in energy policy'.



are used in a 'base case'<sup>1</sup>, and then varied to produce other cases, including a 'worst case', in order to assess the sensitivity of cash flow.

Wind, refuse burning and anaerobic (sewage) digestion produce negative NPVs throughout the discount rate range of 5% - 20%<sup>2</sup>.

Figures 132 and 133 provide the variation in the NPV of parish distributed cogeneration, centralised generation and landfill gas over this discount rate range. Graphically showing the NPV ranking of each project (only centralised generation produces negative NPVs above 15%).

The capital cost of the SEB's slow-speed diesels are very high and have the effect of making the cost of centralised generation very sensitive to the assumed discount rate.

1. All NPVs have been estimated in 1992 money values using a 15% discount rate and fuel (Gas oil) price of 14.9p/Litre for distributed cogeneration, in the 'base case'.
2. It may be argued that using discount rates in the range 5-20% would not have started many U.K. mainland energy projects if they had been assessed at rates this high. 8% is the standard U.K. Treasury rate, which was raised from 5% in the mid 1980s. Discount rates of 8% to 15% are typically the rates used on the U.K. mainland.

See U.K. Government economic service working paper 2, 1979, 'The test discount rate and the required rate of return'.

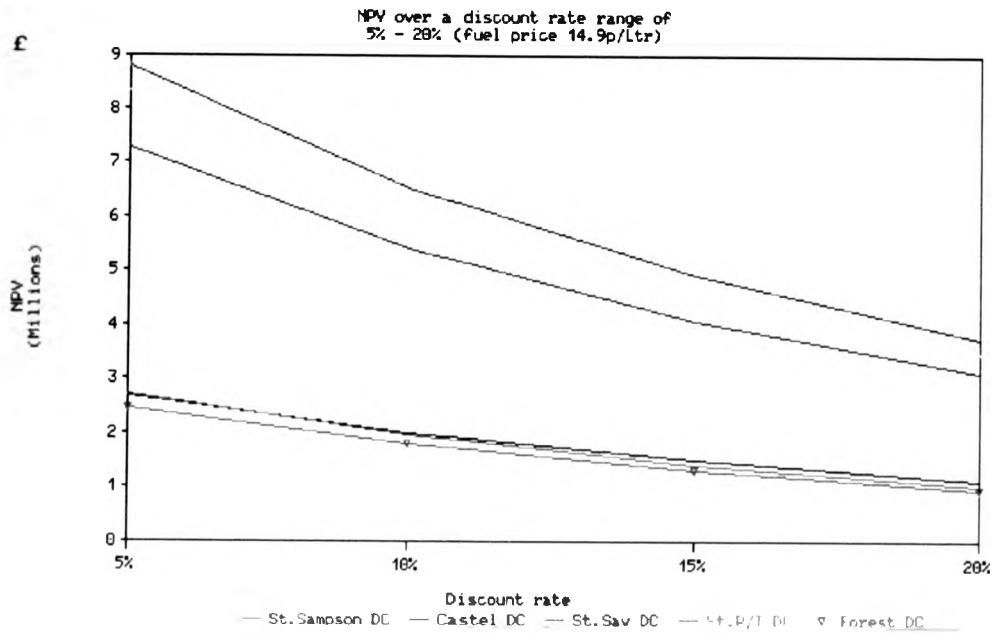

Figure 132

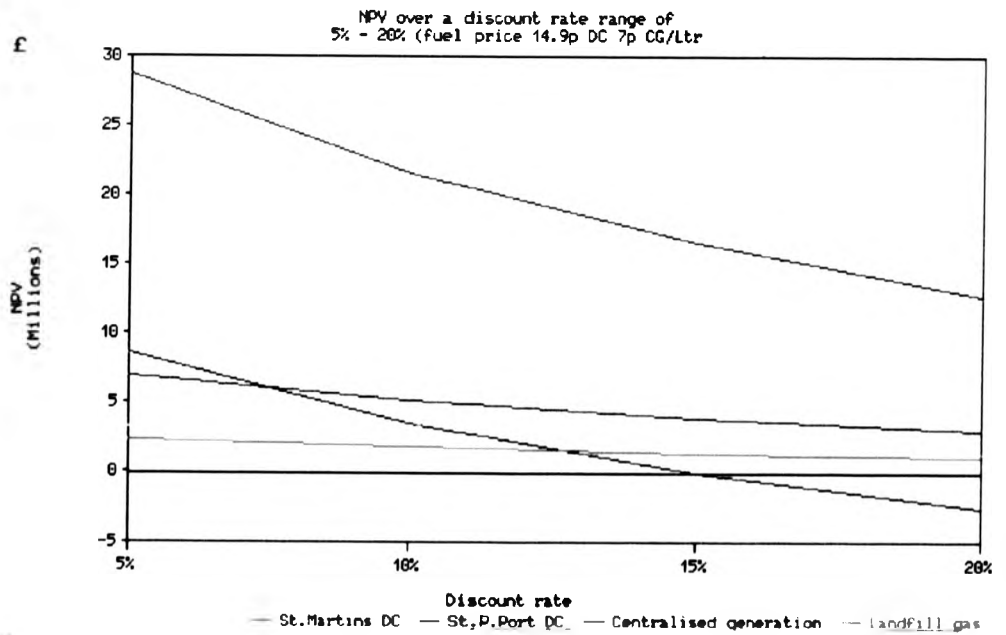
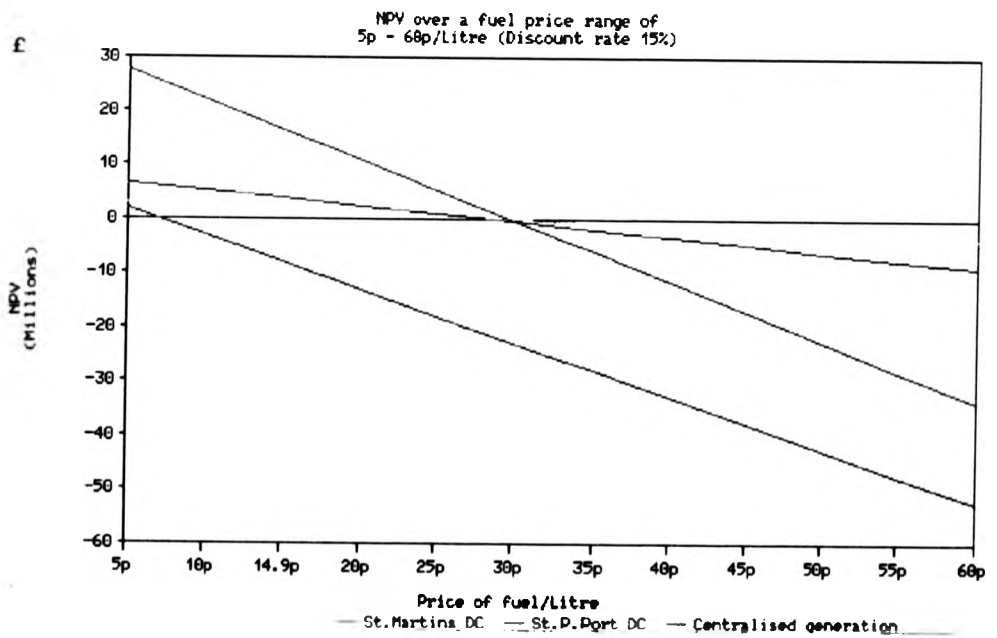
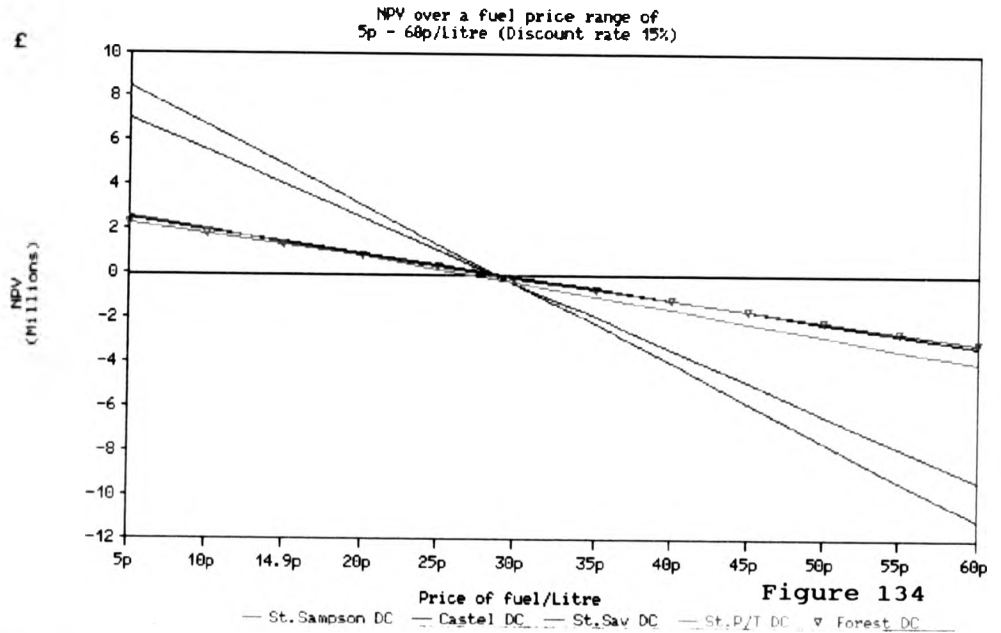

Figure 133

Figures 134 and 135 also provide the variation in the NPV over a fuel price range of 5p/Litre to 60p/Litre.



This similarly provides the NPV ranking of each source but now with variation in fuel price. Distributed cogeneration produces negative NPVs above a fuel (Gas Oil) price of between 28p - 30p/Litre. Centralised generation produces negative NPVs above a fuel (HFO) price of 7p/Litre.

Future fuel price trends are difficult to predict; the volatility of the fuel market to events such as the price rises of 1973/79 (and more recently the Gulf war) make any prediction invidious<sup>1</sup>. However, if the heat price of all fuels rises, then relative to individual heating schemes, distributed cogeneration should remain competitive.

The 'worst case' occurs with the quadrupling of the present oil price (Gas oil to 60p/Litre for example) and discount rate at 20%<sup>2</sup>. When the discount rate is 15% and fuel prices are assumed to DOUBLE the economics of distributed cogeneration sources are reasonably robust, centralised generation sources are much less so.

These assumptions on discount rates and future fuel costs may be far more important to very small islands (such as Guernsey) than demand side energy efficiency levels.

Having obtained an assessment of heat demands (see Chapter 9) and selected modular plant for each ESCo, we now

1. Oil and oil products are directly priced in U.S. dollars and the exchange rates between the dollar and the U.K. pound is of considerable importance.
2. Large changes in oil prices are the 'marker' for very many other basic price levels, including currency, perturbations in the cost of capital (interest rates) etc.

turn our attention to the determination of heat network sizing and overall costs.

### 11.3 Heating networks

Our analysis assumes that all heat demand is supplied from one cogeneration site within each parish; no other boilers located elsewhere<sup>1</sup>. It includes for waste heat boilers and also the 'worst case' supplementary heat boiler requirement for each project (ie. with minimum waste heat from cogeneration plant and maximum parish heat demand; see TABLE 9.13).

The simplest case of a hot water heating network constitutes one main heating conduit, Figure 136.

Simple hot water heating network

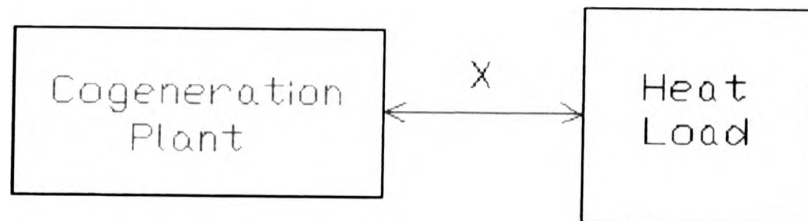

$X$  = Length of main heating network

Figure 136

1. This is not to say later, that inter-parish links may not be viable or that privately owned supplementary boilers may not play a marginal role.

When extending the main line, the annual cost of transmitting heat in the distribution network is approximately proportional to its length. The installation consists of flow and return hot water pipes and uses polyurethane foam pre-insulated pipework. The design is based on a main arterial (primary) network which feeds flexible heating pipes to heating loads<sup>1</sup>. Flow temperature is no greater than 120 C and hot water is supplied from each ESCo site and pressurised using a single pump (a standby pump is available).

As the routing of the buried mains are to cross below road ways and run through occupied areas, the number of points where access is required should be minimal.

The connection and control of the hot water distribution network is considered in the present work only as part of the ESCo connection. The Combined Heat and Power Association have published<sup>2</sup> with regard to end-user's central pumping, temperature control etc. Individual end-users are usually provided with valved flow and return pipes located in a trap adjacent to their premises (metered by mechanical or electronic heat meters).

1. Flexible heating pipes offer substantially lower cost; two network heating tails to each building.

Temperature difference between water supply and water return is assumed constant.

2. Combined Heat and Power Association, 1990, 'Guide to the implementation of combined heat and power community heating schemes'.

The derived probable maximum heat energy demands for each parish can now be used for dimensioning each network (see Section 9.2), TABLE 11.4. The usual problem with heating network schemes is the high distribution costs associated with a large number of small customers, over a wide area.

TABLE 11.4 - Probable maximum parish diurnal heat energy demands<sup>1</sup>

	Probable max heat demand (Mwt)	Probable max heat consumption (MWht)
Vale	44.0	697
St.Sampsons	125.0	1475
Castel	20.0	319
St.Saviours	10.0	149
St.P/Tort	21.0	301
Forest	8.0	124
St.Andrews	11.0	167
St.Martins	23.0	386
St.Peter Port	108.0	1526

This is not the case for the class of very small islands considered in the present case. Heating networks on these islands will NOT be spread over wide areas (and they have high population densities); which may offer a significant strategic energy conservation choice (which has had little research to date).

#### Cost of the heating network installations

Parish heating networks require high investment in distribution (primary) mains and pumping and a number of

1. Heat loads are assumed uniformly distributed within each parish.

See APPENDIX M - Probable ESCO composite (diurnal) heat profiles.

people have published<sup>1</sup> estimates of these network costs (which are generally complex and detailed<sup>2</sup>). In the present work rule of thumb estimates are provided by Sheffield Heat and Power Limited<sup>3</sup>, as follows:-

Cost of boilers:

A cost estimate of £30,000/MWt for waste heat boilers (for heat recovery purposes) and also supplementary heat boilers (1992 prices) is used.

Cost of pipes:

District heating pipe of 150 mm<sup>2</sup> internal diameter is selected for Vale, St.Sampsons and St.Peter Port and 100 mm<sup>2</sup> i/d for the remaining parishes<sup>4</sup>. With cost estimates of £550/metre and £450/metre (1992 prices) respectively for the pre-insulated pipe (with leak detection). The costings include the formation of a trench

1. See Andrews, D.C and Lowe, R.J, 1981, 'The economics and relevance of medium, small and micro combined heat and power/district heating' for example.

2. For other references relating to network studies see:-

Energy Paper No 20, 1977, 'District heating combined with electricity in the United Kingdom' or

Macadam, J.A, Jebson, D.A, Owen, R.G and Brogan, R.J, 1981, 'District heating combined with electricity generation: A study of some of the factors which influence cost-effectiveness' or

Cassels, J.M, 1980, 'Some remarks about district heating network costs'.

3. Brooks, S, 1992, Development Manager - Sheffield Heat and Power Limited, personal communications.

4. Fees/connections to properties, 50-80 mm<sup>2</sup> i/d.



and backfilling to house the buried section of pipework, and also the formation of valve and drain pits.

There are various geometries of primary heating network possible for each parish, which make estimates of network costs complicated. Our computer aided planning work in Section 9.4 however suggests that for testing purposes, a simplified pipeline network which represents the peripheral length of each parish is a feasible model; Vale (12 km), St.Sampson (10 km), Castel (14 km), St.Saviour (10 km), St.P/Torteval (12 km), Forest (8 km), St.Andrews (8 km), St.Martins (12 km) and St.Peter Port (10 km).

Cost of pumping:

The heating networks, in order to give satisfactory circulation, require to be kept full of water at all times. The fluid (water) must be at positive pressure in all parts of the network to prevent cavitation.

To satisfy a heat load which varies from maximum to minimum heat demand the variation has to be met by varying the quantity and/or temperature drop between flow and return. The costings in the present work therefore include for a variable speed single pump, with a standby pump available (a normal/standby twin pump set).

To ensure that each end-user connected to the network receives the required amount of circulated water over the load range, it is necessary to provide means of regulating the volume of water through each connection. Two-port valves with differential pressure control are therefore used to

automatically keep the network in balance and facilitate the use of the variable speed pump.

Running costs after installation are significant, with pumping the biggest operational cost. A figure of electricity needed of 1.5% of the energy delivered is used, as recommended by Sheffield Heat and Power Limited. For example, the maximum diurnal heat energy delivered in St. Peter Port is 1526 MWht (see TABLE 11.4); the electricity needed for pumping 23 MWhe.

The capital cost of pumps depends upon the requirement for controls. A price estimate of £50,000 for each pump (1992 prices) is used (again recommended by Sheffield Heat and Power Limited).

Cost of maintenance:

The total annual maintenance cost is taken as 1% of the total investment cost.

#### **Total fixed and variable costs**

A TABLE can now be produced which estimates the fixed and variable heat network costs for each parish, TABLE 11.5.

Fixed costs represent the total capital cost of each parish heating network (paid at once) for a 30 year life-time<sup>1</sup>.

1. Important is that this implies three distributed cogeneration equipment life-cycles.

TABLE 11.5 - Estimated parish heat network costs (1992 prices)

	Fixed cost (£ million)	Annual variable cost (£)
Vale	7.96	141,666
St.Sampsons	9.59	162,050
Castel	7.06	102,904
St.Saviours	4.93	64,300
St.P/Tort	6.25	91,828
Forest	3.97	50,008
St.Andrews	4.00	54,960
St.Martins	6.28	101,830
St.Peter Port	8.69	200,075
	-----	
	58.73	

Variable costs represent the total annual operating and maintenance costs of each heating network.

Neglected are the costs of water and also heat losses (heat distribution distances will be very short) and no provision to optimise the availability of heat (for instance, by thermal storage; see the discussion in Section 9.2).

#### 11.4 Longer term (30 year) benefits

There is a necessary requirement here to resist the temptation to focus on the short-term objectives at the expense of medium and longer-term (30 year) strategic energy thinking<sup>1</sup>. We need now to account for the total capital costs (including the heating networks<sup>2</sup>), fuel costs and

1. The parish ESCo idea ensures that the ESCo is the main contractor and that the end-user is involved in minimum capital expenditure.
2. There is little or no capital investment needed for the Island electricity network, in fact parts of the network (33 kV transmission) can be taken out of service.

operation and maintenance costs<sup>1</sup> (including the heating networks).

This requires a move away from NPV analysis towards the development of a unit price of energy for each ESCo (kWhe and kWht). With a much broader notion, corresponding to a more desirable accounting position, now to include depreciation provision.

The costing methodology used in the present work adopts the 'contribution' approach (one of marginal costing<sup>2</sup>). Which advocates that the marginal cost of a product includes only the direct or variable costs and makes no attempt to absorb overheads (as in the absorption approach for example).

'Contribution (C)' is defined as the difference between sales revenue (kWhe/kWht) value (SR) and the marginal cost of sales (SV); with no net profit arising until the contributions equal the fixed overhead (F)<sup>3</sup>. When this level of overhead of output is achieved, the ESCo is then said to break-even as neither profit nor loss occurs.

TABLE 11.6 provides the break-even unit costs for each parish ESCo (which includes depreciation provision, but no

1. Outage/scraping and environmental costs are neglected.
2. The advocates of marginal costing maintain that an apportionment of fixed costs to production is unsound because of the fundamental distinction between fixed and variable costs.
3.  $S(R - V) - F = \text{Profit/loss}$  (where  $S(R - V) = C$ )

interest charges).

**TABLE 11.6 - Break-even unit costs for each parish ESCo (including depreciation, but no interest charges)**

Parish	pence/kWhe	pence/kWht
St.Peter Port	5.60	0.63
Vale	6.09	0.60
St.Martins	7.04	0.58
St.Sampsons	7.41	0.43
Castel	7.29	0.75
St.Andrews	8.96	0.72
Forest	9.06	0.99
St.Saviours	9.69	0.74
St.P/Torteval	10.38	0.48
	-----	-----
Average	7.95	0.66

When compared with the present average centralised price of energy (9.37 p/kWhe and 1.85 p/kWht), there is no a priori requirement to establish capital contributions from the States of Guernsey to achieve break-even unit costs.

Important is the 85% difference between the lowest and highest cost of parish energy service. The last four parishes in the list are particularly costly to serve, and maybe this should be a future guide to tariff development. Even though there are more than eleven orders of magnitude difference between the installed capacity of the smallest and largest ESCo (see TABLE 11.1).

Williams<sup>1</sup> and also Belding<sup>2</sup> have described studies of the economics of cogeneration as essentially a direct

1. Williams, R. H, 1978, 'Industrial cogeneration'.

2. Belding, J. A, 1982, 'Cogeneration'.

comparison between the price of electricity from cogeneration plant and that supplied from existing centralised power stations, and a similar approach is taken in the present work. Figure 137 shows the unit price paid for centralised electricity (and also the typical centralised heat energy unit price) by end-users on Guernsey in 1992. This is compared with the estimated average break-even unit cost for electricity and heat energy from parish ESCos.

### Comparison of centralised unit price with average ESCo break-even unit cost

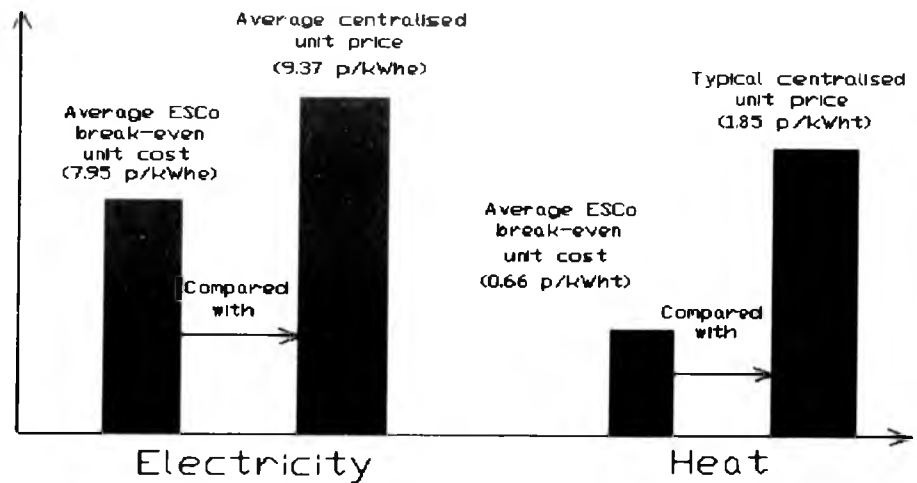

Figure 137

Which suggests that Island wide implementation of distributed cogeneration (even with high capital cost heat networks) may be a useful way of lowering the cost of energy service (as well as significantly reducing prime fuel imports).

Regardless, distributed cogeneration also offers 'other benefits' which are not offered by central power stations, which may be a significant part of its value. It is important therefore, when considering the average ESCo break-even unit costs (Figure 137), to attempt to take these benefits also into account.

The likely benefits are:-

(1) The 'total energy bill' for the Island is very important, and was quantified in the 'Energy Market Analysis' sub-system, and estimated to be £50 million at 1992 prices (see Section 5.2<sup>1</sup>).

Neglecting transport, the Island's centralised energy bill is £36.2 million; with distributed cogeneration this drops to some £29 million<sup>2</sup>. An annual saving on energy imports alone of £7.2 million.

(2) An increase in Island energy supply security; where the constraints imposed by St. Sampson's harbour are particularly important. In that they impose extra transport costs on fuel importers due to the large number of shipments that have to be made to the Island (more than 120 oil and coal shipments in 1990 for example, see Section 4.3).

The 23% reduction in fuel imports (see Section 9.2) is equivalent to a reduction of some 43 shipments per year

1. With the nominal price of oil low at the time of writing.
2. Again using the tariff costs in the domestic energy market (see TABLE 4.9); using Gas Oil retailed at 5% below the price of Kerosene (see Figure 9.10, Section 9.2).

into the Island, and an increase in Island storage capacity of some three months.

Guernsey's energy imports by sea are also a major source of energy consumption in itself; the energy requirement of shipping arising from three main contributions:-

- (1) Direct fuel consumption.
- (2) Construction of the vessel.
- (3) Maintenance of the vessel.

The two main factors affecting the fuel requirement of a ship is its size and speed. A 20,000 tonne cargo for example has a typical gross energy requirement of 0.375 MJ/tonne-mile<sup>1</sup> (which includes a 12% allowance for the construction and maintenance of the ship).

A delivery of HFO into the Island (of 2500 tonnes, Grangemouth to Guernsey, 750 miles for example, see Section 4.1), computes to 8 MW per journey. Multiplying this by the total number of prime fuel deliveries per year (circa 120), the annual energy used in ship transportation is in the order of 960 MW.

With distributed cogeneration (and a reduction of 43 deliveries) this would reduce energy consumption by sea delivery alone by 344 MW (36%).

1. Average values are taken from typical performance characteristics of all types of ships from the proceedings of a conference on shipping held at the University of York, 5-7 September 1989.



### (3) Increased diversification

When a generating plant problem has occurred at the centralised power station in the past (with large machines) it has led to Island black-outs. The case of Friday 3 June 1994 for example<sup>1</sup> (1.45 pm - 4.30 pm), resulted in the Island having no electricity supply for over two hours.

The estimated loss in SEB unit sales was only 87.5 MWhe (with a 1992 monetary value of £8000). However, the loss of computing/communications within the Guernsey financial services sector was large, but is difficult to quantify in money terms.

With dispersed, modular (smaller) cogeneration units this risk would be reduced.

### (4) Reduced air pollution

The deployment of distributed cogeneration would affect air pollution primarily in two ways:-

(a) There would be new emissions from the parish ESCos, but these would be counterbalanced by

(b) the reduction in emissions from conventional heat-only boilers and the central power station (see TABLE 9.10).

362 \* 10<sup>6</sup> kg of CO<sub>2</sub> and 3.32 \* 10<sup>6</sup> kg of SO<sub>2</sub> was emitted into the atmosphere as a result of energy use on Guernsey in 1990 (not including transport, see Section 8.5).

1. Guernsey Evening Press, 4 June 1994, 'Micky mouse power cut'.

With distributed cogeneration these emissions may fall to  $256 * 10^6$  kg for CO<sub>2</sub> (an annual reduction of 29%) and to  $0.4 * 10^6$  kg for SO<sub>2</sub> (an annual reduction of 88%).

Monetary values are extremely difficult to quantify at present, however for illustrative purposes, for CO<sub>2</sub>, Evans<sup>1</sup> took 2 p/kg, which represents the unit cost of the cheapest option for removing CO<sub>2</sub> from flue gas<sup>2</sup>. On this basis, the annual monetary benefit for CO<sub>2</sub> alone may be £2.1 million.

Further monetary benefits may also accrue in respect of SO<sub>2</sub> and NO<sub>x</sub> removal, but these will be smaller and are ignored.

In the parishes of St. Peter Port, Vale and St. Sampson in particular, the Writer and a research assistant<sup>3</sup> found the detrimental effect of air pollution on vegetation near the main roads for example. Indeed, it could be said that transport energy usage may be of far greater relevance environmentally, but this needs further study.

#### (5) Improved energy quality matching

The better matching of energy quality, particularly in the domestic sector (see Sector 8.4), suggests a potential reduction in prime fuel imports of 7%.

1. Evans, R, 1993, 'Environmental and economic implications of small-scale CHP'.

2. See also Verbuggen, A, Wiggin, M, Dufait, M and Martens, A, 1992, 'The impact of CHP generation on CO<sub>2</sub> emissions'.

3. See Black, K, Fielden, D and Jacques, J.K, 1991, 'An investigation of the air pollution produced by energy use on Guernsey'. University of Stirling internal report.

(6) Reduced 'social' costs

There may also be social benefits provided by distributed cogeneration, which should not be ignored. The States spent over £30 million for example on Social Services in 1992<sup>1</sup>; a small proportion of which went to pay fuel bills for domestic end-users who could not afford to pay themselves (States supplementary heating allowances for example). Fewer houses crumbling prematurely because they are presently inadequately heated over their life-span may be another example.

(7) The affect on employment levels

There is little knowledge about the relationships of energy use and employment, but some studies<sup>2</sup> suggest that conservation investments may have employment benefits.

(8) Depleting energy resource cost

This is a 'global level' perspective and any sensible estimate of the long-term availability of petroleum products is difficult (see Section 12.1).

**11.5 Longer term (30 year) costs**

It is necessary and reasonable that a regulated parish ESCo receives revenues that equal its costs plus a fair rate of return on capital. Each has to utilise operating and financial leverage in the hope of earning returns in excess

1. See Advisory and Finance Committee, 1992, 'Budget 1992'.

2. See Jaccard, M and Sims, D, 1991, 'Employment effects of electricity conservation: The case of British Columbia' for example.

of the fixed costs of their assets and liabilities, thereby increasing the returns to their shareholders.

If each parish ESCo project does not achieve a rate of return sufficient to achieve complete private sector funding, the question of States support needs to be examined<sup>1</sup>. Enhancing the attractiveness of the investment through the regulatory sub-system of the SOGEMS, to guarantee economic viability for example. The SOGEMS will thus impose conflicting pressures on parish ESCos, as shown in Figure 138.

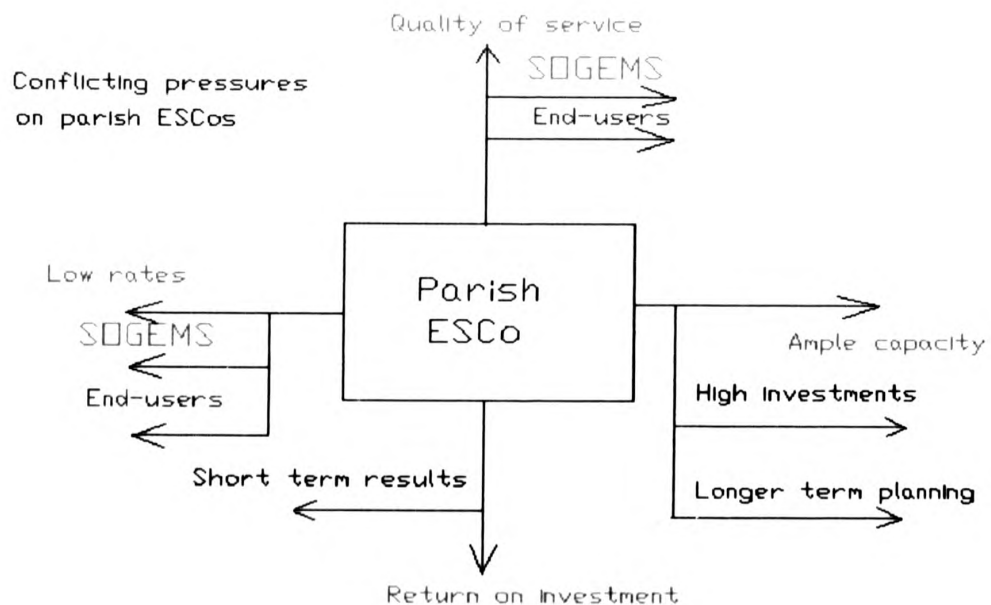

Figure 138

1. The economics made to work (if necessary) by direct States of Guernsey subsidy.

The cost of borrowing is THE most important factor in determining the ESCo's rate of return; ESCos therefore need to have access to funds<sup>1</sup>.

Commercial capital may be difficult to acquire and becomes increasingly more so with increasing risks and uncertainties. Capital intensive processes face particular difficulties anyway, in times of rising energy prices when capital becomes scarce<sup>2</sup>, which may be all the more reason to start implementation now when energy prices are low.

The present Trading Boards are committees of the States just like any other committee. Yet they have had commercial freedom, with accounting and financial affairs traditionally dealt with by the Trading Boards themselves. They have never formed part of the central financing and accounting systems relating to the general revenue account of the States<sup>3</sup>.

Until approximately 1987, the SEB have been a net borrower of capital, raised commercially (Barclays Mercantile loan for 3C and Trustee Savings Bank loan for 4C for example) and have not invested surplus funds in any sophisticated manner. With the BCCI debacle within the SEB<sup>4</sup>

1. In addition to start up costs, the ESCo may also need access to low cost borrowing to also economically fund demand side energy saving investment for example.
2. See Woodward, A, 1992, 'Financing waste to energy plants' for example.
3. In some cases this provision is contained in legislation (as with the SEB for example, derived directly from the 1933 Law, see Section 6.4).
4. In 1991, a loss of some f5 million occurred through the failed Bank of Credit and Commerce International.

the Advisory and Finance Committee insisted that it would be in the best interests of the States of Guernsey if Trading Boards no longer continued to manage separate investments, and monies were then 'pooled' with the general monies<sup>1</sup>.

The general funds of the States are generally derived from many sources, the most significant are:-

- (1) The excess of income over expenditure on Revenue account.
- (2) The balance on the Capital Fund.
- (3) The Note and Coin issue.

The level of the 'pooled' funds vary considerably due to the timing of income and expenditure flows and a large degree of liquidity is required. Capital investment on the Island is therefore dealt with by the States Treasury in consultation with Union Discount<sup>2</sup>. Since the cost of borrowing is the single most important factor in determining parish ESCo rates of return, there is no reason why a low cost borrowing facility should not be made available to the SOGEMS.

Instead of commercial loans at commercial rates to finance centralised 'prepared' energy carriers. Rather low

1. See Billet d'Etat XXII 1991, Wednesday 31 July 1991.

2. The Advisory and Finance Committee employ the services of Union Discount Asset Management C.I. Limited to assist in the management of these funds. Who monitor banking organisations worldwide from various sources, including the main rating agencies.

cost centralised bulk (States) borrowing to finance decentralised energy services may make more sense.

Heating networks are most often installed by communities who ascribe relatively low interest rates to the money employed in high initial capital investments. This has to apply on Guernsey also, with low interest rates assigned to favour energy conservation.

This course of action has already been mooted anyway by the States<sup>1</sup>:

"it could be argued that in the case of energy considerations, the normal financial criteria applied by commercial organisations are inappropriate and that alternative criteria should be applied for the benefit of the Island as a whole".

The question as to what levels of interest rate would be required to make the various parish ESCo projects a reasonable prospect need to be identified. On the U.K. mainland for example, government projects are now required to earn a rate of return before tax of at least 8%<sup>2</sup> in real terms (increased from 5% to 8% in the 1980s). The logic underlying this required rate of return is set out in detail in Command Paper 7131<sup>3</sup>.

1. See Billet d'Etat XVI, July 1988, page 610.

2. This ROI was determined following an examination of the pre-tax real rates of return on assets achieved by private companies.

3. U.K. Government Command Paper 7131, March 1978.

The reasoning is that if resources are used for investment by government this occurs largely at the expense of their use in other parts of the economy. Thus it is in the national interest for government to seek to ensure that where these resources are used in the public sector they achieve a return not less than they would have attained elsewhere<sup>1</sup>.

Some comparisons between the recently privatised electricity industry on the U.K. mainland and the present case are useful here. Thomson<sup>2</sup> for example indicates that the regulatory mechanism imposed on the U.K. Regional Electricity Companies (RECs) considered carefully the profitability of each business in setting price limits<sup>3</sup>. All are broadly consistent with a real rate of return of around 10% on assets.

In relation to the debt structure of the RECs (set up at privatisation) Thomson suggests that it may be related to the previous external financing limit set by the U.K.

1. Given this method of selecting the required ROI we might expect, in principle, the returns on distributed cogeneration and demand side conservation investments to be broadly in line.
2. Thomson, L, 1994, 'Accounting and regulation in the privatised electricity supply sector in England and Wales'.
3. The essence of the argument supporting price cap rather than rate of return regulation is that it provides an incentive for cost reduction, as companies reap the benefit in terms of increased profitability.

See for example Glynn, D.R, 1992, 'The mechanisms of price control'.



Treasury (but in an earlier work<sup>1</sup> notes that this is an area which needs further study). In the present case we assume a debt to equity ratio of 1.00 for each ESCo.

As part of the U.K. privatisation programme the electricity transmission function was set up as the National Grid Company Limited. Shares in the company were allocated as a 'gift' from the Secretary of State for Energy to the RECs. There is no reason why similar arrangements with the SEB electricity network could not be made with the nine parish ESCos or otherwise.

The ROI that would be achieved by each parish ESCo with no interest charges (and energy tariffs set the same as centralised charges) is provided in TABLE 11.7.

**TABLE 11.7 - ROI from each parish ESCo with no interest charges and tariffs set the same as centralised charges**

Parish	ROI (%)
Vale	24
St.Sampsons	17
Castel	10
St.Saviours	4
St.P/Torteval	6
Forest	3
St.Andrews	5
St.Martins	14
St.P.Port	33

1. Thomson, L, 1993, 'The financial and accounting implications of the privatisation of the regional electricity companies in the U.K.'.

### Important ESCo costs

#### (a) Interest rates

When interest charges are included, TABLE 11.8 shows the ROI from each parish ESCo with interest rates through the range 5% to 20% (fuel price @ 14.9p/litre).

TABLE 11.8 - ROI (%) from each ESCo with interest rates through the range five to twenty percent

Parish	Five percent	Twenty percent
Vale	21	14
St.Sampsons	14	7
Castel	8	0
St.Saviours	1	- 6
St.P/Torteval	4	- 4
Forest	0	- 7
St.Andrews	3	- 5
St.Martins	12	4
St.P.Port	31	23

At 5% interest rates, all parishes produce a ROI except Forest which breaks-even; at 20% interest rates, four parishes require annual grant aid to achieve break-even. Important is that with cross-subsidy between parishes, all ESCos can achieve profitability broadly consistent with a real rate of return of 7%, at 20% interest rates.

#### (b) Fuel costs

With regard to fuel price sensitivity and its effect on ESCo ROI, centralised island utilities usually apply a fuel price escalation clause. Which ratchets up final user prices to maintain their ROIs (usually to the complete exclusion of end-user opinion). If fuel prices rise, then relative to individual heating schemes, distributed cogeneration should remain competitive.

(c) Heating network costs

Heat network costs do have an effect on the economics of distributed cogeneration, particularly at high discount rates<sup>1</sup>. Our approach in the present work has been to consider a simplified heating network for each ESCo (see Section 9.4) and to consider the overall feasibility of distributed cogeneration over nine parish clusters, on a comparable basis. Thereby providing an overview of the economic outcome for the Island.

Further sensitivity analysis would not provide much further insight, but rather a full engineering appraisal is now required which is another large (and separate) major task outside the provenance of this thesis.

(d) Heat/power ratios

As heat to power ratios are increased in cogeneration design, the total efficiency falls off (the cogeneration process is better the lower the heat to power ratio). In general, the present study uses a heat/power ratio of 1.4 with an electricity conversion efficiency of 35% (with small variations due to the availability of commercial cogeneration plant).

Any significant difference would lead to a more subtle distinction between income from cogeneration and the requirements of supplementary heat, but this should not appreciably alter our overall conclusions (see Chapter 12).

1. Important though is the considerable scope for new methods of pipe laying, new pipe materials etc in the future.

### Important system costs

In changing the system there are also three other major costs:-

(1) Greater penetration of domestic wet central heating installations is one, which is required to maximise the displacement of imported fuel by the use of waste heat<sup>1</sup>. In order to achieve this displacement, 1,622 more wet central heating end-users (than are currently available on the Island) need to be connected to heating networks (which is the work of ESCo marketing).

With an individual wet central heating capital cost of £3000 (1992 prices) for a typical 3 bedroom Guernsey cottage. This would result in a total capital requirement of £4.9 million; but this need not necessarily be financed out of the savings of the system.

(2) The cost of setting up and running the SOGEMS itself; provisional annual budgetary (1992) estimates suggest:-

	£
1 - SOGEMS manager	35,000
1 - Energy planner	25,000
1 - Regulator	25,000
Computer hardware/software	30,000
Office running costs	35,000
	-----
	150,000

1. Which (under regulatory control) may replace environmentally poor fuels such as Coal (see Section 9.2):-

#### Displaced fuel imports (GW)

Coal	187
LPG	66
Oil	68
	---
	321

External co-financing of part of this expenditure from other bodies (for example the EU) may be possible. A major part of this research effort however has already been operated on paper in the present work, covering the two major sub-systems of the system.

(3) The delivery of Gas Oil to dispersed ESCo sites is the third. It may be the case that the energy savings on shipping prime fuel to the Island may be counterbalanced by the energy required to transport Gas Oil to distributed ESCo sites on the Island. Gas Oil can be safely transported and stored at these sites without a licence (see Section 6.4). Important is that oil products are presently transported by road to all parts of the Island anyway.

Changing the system may produce no coal deliveries by franchised lorry drivers; no HFO/Product 469 deliveries to growers etc, and need not result in numerous road transport deliveries of Gas Oil to ESCos. What is required is the evolution of a new Gas Oil distribution network on the Island. Gas Oil from existing oil agency storage at St.Sampsons harbour suitably routed to dispersed parish ESCo storage sites.

A number of possibilities could be proposed to resolve this problem; the upgrading of the existing Guersey Gas pipeline between St.Sampsons and St.Peter Port may be one (see Section 4.3). The pipeline (or similar) extended to supply Gas Oil to northern ESCo sites for example, such as Vale, St.Sampsons, Castel, St.Andrews and St.Peter Port. The

oil agencies themselves may also have a number of proposals, but all of this is not wholly relevant to the present work.

Important is that the cost of road tanker delivery of oil products from storage to end-user is INCLUDED in the per litre purchase price of the fuel. This inclusive charging system is used by each of the four agencies on the Island (see Section 4.3), and is also used in our computer modelling thus taking account of these transportation costs.

#### **The economic benefits of changing the system**

When considering these longer term (30 year) costs and benefits it is not easy to quantify exactly what the premium has to rise to, to take the savings into account. Further research effort is required to refine (in detail) each one of these cost and benefit areas.

What really matters to very small island communities however, is the preeminent aim of reducing petroleum product imports. With distributed cogeneration this has been shown to be achievable, and may also bring with it a significant monetary benefit to the Island. Ignoring any other benefit, it results in an annual saving of some £7.2 million on energy alone, as a first approximation.

Uneconomic parish ESCo projects (see Section 11.2) may not be easily financed through the private sector

financial markets<sup>1</sup>, but they could be implemented by the introduction of a subsidy from the savings of the system (via the SOGEMS).

The level of annual subsidy that would be required to produce break-even unit (kWh) costs for a 300 kWe wind turbine for example, would be £10,420. For anaerobic (sewage) digestion £42,875. These savings could also be used to provide financial support for demand side measures, which we discuss in the next Section.

To take account of the economic benefit of reduced oil imports ALONE, the value of the premiums for electricity and heat are 2.64p/kWh and 0.234p/kWh respectively. Which produce net costs of delivered energy service of 5.31p/kWh and 0.426p/kWh, Figure 139.

In very small (densely populated) island situations (where imported energy is of major concern) island wide implementation of distributed cogeneration may therefore be a useful way of improving overall economic efficiency (and may provide a more equitable apportionment of location specific tariffs).

1. The impetus to establish renewable generation sources on the U.K. mainland for example, was brought about by privatisation of the U.K. electricity supply industry. At the time of privatisation the U.K. Government created a mechanism known as the 'Non-fossil Fuel Obligation' by which RECs are required to purchase a percentage of their electricity from non-fossil fuel sources. The offer of a guaranteed price for electricity helped to secure funding for these non-economic renewables.

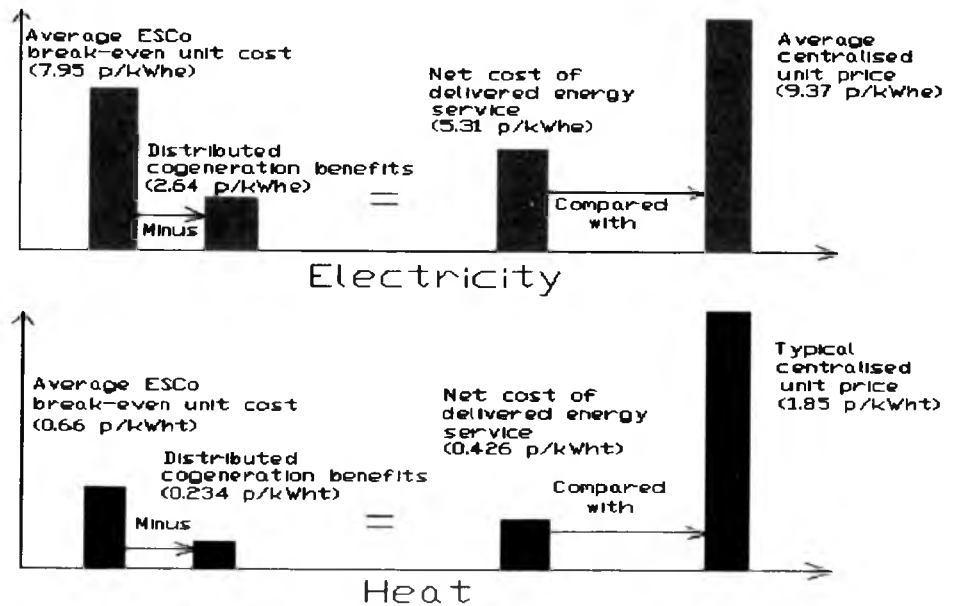

Values of the premium required to take the benefit of reduced oil imports into account

Figure 139

The present work though is not a treatise on tariff construction (ensuring that unit price correctly reflects the true cost of geographic production and distribution for example), and will therefore not discuss energy tariffs in any depth (many others have done so<sup>1</sup>). Nonetheless, the present work does indicate that the energy pricing levels produced by changing the system should not result in the aggravation of the economic and social conditions within the

1. See for instance Friedman, L.S and Weare, C, 1993, 'The two-part tariff practically speaking' or

Wirl, P, 1991, 'Woodle peaking caused by time of day tariffs'.



Island. In fact they may well be enhanced, with greater security of supply, greater diversification and lower air pollution.

#### 11.6 ESCo demand side projects (the next step)

The division of energy-related investment into two categories (namely energy supply and energy demand) is in many ways not correct. Energy related investments take place at a number of stages before energy reaches the final point at which it is used. Investment in energy-using equipment is therefore not confined to the latter stages and there are difficulties in making a clear distinction.

An investment in the early stages of the chain results in an improvement in the efficiency with which energy is supplied (for example through distributed cogeneration) and may have longer term (30 year) benefits (see Section 11.4) than the more indeterminate final user end.

The present work proposes a systemic approach to the Island's energy problem, with the SOGEMS setting the strategic 'energy conservation environment'. With reliance on policy-assisted, market-oriented mechanisms<sup>1</sup> at the parish level.

If the States of Guernsey were to decide to directly subsidise parish ESCo demand side energy conservation

1. Other writers have also suggested market-orientated mechanisms for facilitating the dissemination of energy efficiency improvements, for example Reddy, A.K.N, 1991, 'Barriers to improvements in energy efficiency' for example.

projects, the prediction of its real impact would be difficult. The extent to which such investment would occur, which would otherwise not have taken place, would be difficult to measure.

In contrast, a parish ESCo would exist to invest in demand side energy efficiency improvements as well as distribute and provide energy needs. Its demand side strategy (through regulation) would be directed at all energy end-users (households, enterprises etc). With ESCos playing a central role in increasing the efficiency of energy end-use.

Demand management<sup>1</sup> usually refers to actions taken by centralised electricity companies to encourage a shift in electricity demand to off-peak periods. It is indeed necessary that demand side peaks be 'smoothed' and parish ESCos also need to consider this to further improve their energy conversion efficiency (which should also include electric transportation<sup>2</sup>).

For the most attractive demand side energy efficiency measures, it has been found by others<sup>3</sup> that conservation capital costs have been more than offset by the saving in

1. Demand management includes all means of influencing the Quality, Quantity and Timing of energy consumption.

2. See also Robinson, E.D, 1993, 'Demand side management includes electric transportation'.

3. For general references to particular industries and their potential for cost savings see Energy Management 'Focus' pamphlets, Energy Efficiency Office, London.

energy costs. The range of technical measures which can be applied to a building or end-user though is dependent on specific instances. There are a number of measures which more often than not can be easily identified (and quantified) through energy surveys, which usually result in a payback of less than four years<sup>1</sup>.

As more and more energy conservation measures are undertaken though, the cost of each extra item of conservation becomes greater and the energy savings less. Until the point is reached where the savings are less than the fall in energy costs. At this point the cost of adding one more unit of conservation is just equal to the corresponding benefits in the form of energy savings (marginal costs = marginal savings).

There is a balance to be struck between demand management and demand side energy efficiency measures. A relatively energy efficient ESCo is realised when the total demand versus time curve does not exhibit rapid

1. This is not an exhaustive list but illustrates some of the considerations necessary:-
  - (a) Fitting time switches and controls.
  - (b) Improvement of pipe insulation.
  - (c) Insulation of other services such as hot water cylinders.
  - (d) Lighting controls (it is possible to detect if someone is in a room by using an acoustic detector or infra red sensor for example).
  - (e) Resetting and commissioning existing controls.
  - (f) Draught proofing and door closes.
  - (g) Building insulation.
  - (h) Zoning of heating.
  - (g) Improved maintenance.
  - (h) Good housekeeping (switching off unnecessary lights etc).
  - (i) Improved efficiency of equipment (the choice of an alternative lighting source is almost bewildering; technology improving at a very fast rate).

changes in gradient, but it is beyond the scope of the present work to review the extensive literature on demand side management<sup>1</sup> and energy efficiency measures<sup>2</sup>.

The 'demand pull' of parish ESCOs in the longer term may well be widened from just energy services (and mobility) to security, entertainment, convenience etc. 'Supply push' will come from new cogeneration technologies (for example the fuel cell, see Section 8.2), micro-electronics, entrepreneurs and local solutions (see Chapter 3).

Important is that practical decisions must have regard to what parish energy end-users actually do (or will do<sup>3</sup>),

1. See Moe, M.L, 1991, 'What a well equipped customer can do to shift energy use' or

Parks, T, 1991, 'Whats the connection between home systems and the electric utilities ?' or

Laine, J.L, Berliner, T and Coleman, M.A, 1991, 'Variable spot pricing with transtext'.

2. For references see for example:-

Domestic: Energy Efficiency Office (U.K.), 1986, 'Energy efficient renovation of houses'.

Commercial/Public buildings:

Field, A, 1992, 'Energy consumption in office buildings' or

Department of the Environment (U.K.), 1994, 'Introduction to energy efficiency in schools' or

Department of the Environment (U.K.), 1994, 'Energy efficiency in council housing: Guidance for local authorities'.

Tourism: Energy Efficiency Office (U.K.), 1994, 'Energy efficiency in hotels: A guide for owners and managers'.

Horticulture/Vineries: Guernsey Evening Press, 25 July 1979, 'Heat saving methods'.

3. See Department of the Environment (U.K.), 1991, 'Attitudes to energy conservation in the home: Report on a qualitative survey'.

rather than confining demand analysis to computing the precise magnitudes of optimal saving in which householders ought to invest. In appraising energy conservation at the final user end, it is important to establish how far individuals are expected to respond of their own accord, and how far their choices are to be influenced by the States.

Whether end-users should be obliged by law to ensure that their properties are adequately insulated for example is very questionable. The authoritarian element of States involvement need only apply in passing legislation to form the SOGEMS itself; parish ESCos and market criteria would apply thereafter.

This inter-relationship between investment in end-user energy conservation and in parish cogeneration plant is a complex one, for two reasons:-

(1) Demand side conservation investments can have many different impacts according to their type, the design and construction of the premises in which they are installed, habits of the owners etc.

(2) The effect on the QQT pattern of demand (and hence on the implications for parish cogeneration plant) may also vary considerably. The motives of end-users are multiple and complex, usefully described as attitudinal, social-diffusion and homeostatic models of behaviour<sup>1</sup>.

1. See Monnier, E et al, 1987, 'Consumer behaviour and energy policy' for example.

We have shown that there is significant potential for demand side energy conservation within each parish; the typical Guernsey home in particular is a good prospect (see Section 8.3<sup>1</sup>). Simply, this is necessarily a local matter (with market mechanisms) and better left to local agreed ESCo solutions.

Outside the domestic sector the effects of demand side measures may well vary widely<sup>2</sup>. In these other sectors (commercial, tourism, vineries and industrial) the energy savings which would result from investment in energy conservation may, if passed on in the form of lower prices, lead to even higher output, which in turn may reduce the savings on energy.

It appears very likely that demand side conservation investments may have markedly different (and largely unpredictable) implications for parish cogeneration plant requirements, with the final impacts differing in magnitude within each of the nine ESCos. As a first step, we have shown that significant, realisable, energy import reductions

1. The main barriers may be that:-

- (1) Householders give energy efficiency measures a low priority in their spending.
- (2) They have a lack of understanding with regard to the costs and benefits of specific measures.
- (3) There is a shortage of capital for investment.
- (4) The tenant/landlord relationship may be a constraint.

2. See Gruber, E and Brand, M, 1991, 'Promoting energy conservation in small and medium sized companies'.

can be achieved through distributed cogeneration, with no sacrifices or upsets to end-user lifestyles<sup>1</sup>.

The question of whether demand side conservation investment saves parish ESCo capacity and in what amounts cannot readily be answered quantitatively in ways useful for Island level energy planning. At the Island level, we have shown that distributed cogeneration saves energy; how market forces will yield any further demand side parish energy conservation needs to be further tested. This should be left to each ESCo to quantify and resolve (with regulatory supervision). ESCos surveying/auditing households/enterprises prior to commencing a programme of energy savings so that ALL buildings might be tackled in priority order.

Important also (in achieving and maintaining these energy savings) is that of continuous monitoring of energy costs and consumption. Simple data is required, such as comparisons of suitable factors like energy per square metre (similar to that provided in Section 8.3). These ratios are of particular value in identifying 'rogue' buildings and those meriting priority attention.

Each ESCo marketing arm therefore needs to have clear goals and objectives (a detailed marketing and operational plan), stimulating end-users to invest in economic energy

1. Conservation generally can involve sacrifices; walking instead of driving a car, houses and offices heated at lower temperatures etc. Distributed cogeneration involves no such changes in lifestyles.

efficiency measures, target good prospects and continuously monitor consumption. All of which are services that Contract Energy Management (CEM) companies on the U.K. mainland are now beginning to offer.

#### **SUMMARY**

- (1) It is important to get closer to the true cost of serving each parish.
- (2) Over a life of ten years wind energy, refuse burning and anaerobic (sewage) digestion have negative NPVs. The figures are not optimistic and are at variance with popular opinion on Guernsey.
- (3) When the discount rate is 15% and fuel prices are assumed to DOUBLE the economics of distributed cogeneration sources are reasonably robust, centralised generation sources are much less so.
- (4) There is a necessary requirement to resist the temptation to focus on the short-term objectives at the expense of medium and longer term (30 year) strategic energy thinking.
- (5) A move away from NPV analysis towards the development of a unit price of energy for each ESCo is necessary. With a broader notion, corresponding to a more desirable accounting position, to include depreciation.
- (6) The cost of borrowing is THE most important factor in determining the ESCo's rate of return.



(7) Instead of commercial loans at commercial rates to finance centralised 'prepared' energy carriers. Rather low cost centralised bulk (States) borrowing to finance decentralised energy services may make more sense.

(8) Island wide implementation of distributed cogeneration (even with high capital cost heat networks) may be a useful way of lowering the cost of energy service (as well as significantly reducing prime fuel imports).

(9) The energy pricing levels produced by changing the system should not result in the aggravation of the economic and social conditions within the Island. In fact they may well be enhanced, with greater security of supply, greater diversification and lower air pollution.

(10) All ESCOs can achieve profitability broadly consistent with a real rate of return of 7%, at 20% interest rates.

(11) Uneconomic parish ESCo projects could be implemented by the introduction of a subsidy from the savings of the system (via the SOGEMS).

(12) With regard to demand side measures, the authoritarian element of States involvement need only apply in passing legislation to form the SOGEMS itself; parish ESCOs and market criteria would apply thereafter.

(13) The question of whether demand side conservation investment saves parish ESCo capacity and in what amounts cannot readily be answered quantitatively in ways useful for Island level energy planning.

(14) Each ESCo marketing arm needs to have clear goals and objectives (a detailed marketing plan). Stimulating end-users to invest in economic energy efficiency measures, target good prospects and continuously monitor consumption. All of which are services that CEM companies on the U.K. mainland are now beginning to offer.

## CHAPTER 12

### CONCLUSION

This work has considered distributed cogeneration in a small island case situation (using techniques that no small island really employs) and is a solution to questions which no-one is really asking.

Distributed cogeneration (as a strategic energy conservation tool) has been shown to be a real economic alternative to expanding centralised electricity generation, which in the past on Guernsey has been considered by some to be utterly unlikely.

When it is possible to produce electricity and simultaneously use the heat with a high overall efficiency, is there any justification for doing it the centralised (conventional) way? We have shown that to question the current energy system is not unreasonable and that by changing the system, a net 'gain' of value to the system proposed may result.

This final Chapter concludes that it is questionable whether the present centralised Island supply of fuels and electricity should continue to expand indefinitely. When alternative (more innovative) approaches might use less fuel to meet energy services at lower cost.

#### 12.1 The need for a new systemic emphasis

The effect of the 'profligate' circle (see Section

10.4), because of the Guernsey 'way of doing things'<sup>1</sup>, has lead to the present energy 'system' on the Island. Which is allowed to continue despite the need to encourage a change of direction in favour of significantly higher energy conservation.

Ever since the 1933 Electricity Act the States have favoured States ownership of the SEB, where legislated monopoly has favoured centralised power generation at Vale.

Broad political goals relating to the use of resources on the Island have been variously described<sup>2</sup> as:

"Land, financial, human and natural resources will be used with maximum efficiency and special regard will be given to the efficient use of world finite resources".

State's publications are usually littered with such statements of one sort or another. The 1991 Policy Planning, Economic and Financial Report for example identified energy as a strategic issue and stressed:

"its importance to the Island in view of its very heavy dependence on oil and its vulnerability to disruptions of supply and unforeseen increases in fuel costs. Whilst the effects of the Gulf War are now receding, the fundamental situation with regard to the world's energy resources means that there is, if anything, an increasing need to establish effective policies for meeting Guernsey's future energy

1. In common with other very small island situations.

2. See Island Traffic Committee/Island Development Committee, 1991, 'A Statement of Vision'.

requirements".

All these statements seem to consist of a clutter of expedients, but nothing really changes.

The present work has shown that resources (energy, capital, manpower) are not being used to their maximum efficiency, and that there is a need for a new systemic emphasis.

Four important factors support this view:-

(1) There is a need to encourage good energy planning (not just merely electricity planning). Energy planning on Guernsey should be providing prudently for the future, something which it is not doing at present. The profligate waste of heat energy from the centralised power station at Vale should cease.

We have shown that there will remain a need to use fossil fuels for the foreseeable future. It is therefore necessary to ensure that prime fuel imports are not wasted, and to squeeze as much 'out of the lemon' as possible. Some writers<sup>1</sup> have focussed on the thermodynamic structure of energy requirements when considering energy matters. The present work indicates that it may be the strategic management of energy resources at the Island level that may be more important. The energy problem is concerned not

1. See Rotty, R.M, and Van Artsdalen, E.R, 1978, 'Thermodynamics and its value as an energy policy tool' for example.

necessarily with technology or thermodynamics but rather the management structure of resource utilisation.

There is a small but significant renewable energy resource available on the Island, and the technologies of relevance have been identified. They are technically feasible, but at the present time most are uneconomic.

Even with increased interest rates and oil prices (and the very small contribution from landfill gas), distributed cogeneration has been shown to be a strategic tool for good energy planning on very small (densely populated) islands.

(2) Important is the need to strike a balance between energy supply and energy demand.

The implementation of demand side energy efficiency improvements (in each economic sector) requires the support and participation of the ultimate end-user and this should be left to the parish ESCo. Regardless we have shown that significant energy savings can be achieved at the Island level by the States themselves, by direct intervention (through the SOGEMS) in the energy market.

This does not mean that final end-users will have to make do with less energy services through reduced energy consumption. It does mean, that through distributed cogeneration, energy conservation becomes the core of the development strategy on Guernsey.

It has to be strategic (for it is an expensive, longer term (30 year) business) and distributed cogeneration should

provide the 'keystone' for this balance. Significantly reducing prime fuel imports into the Island (as a first step), which will then also strike a new balance between the environmental<sup>1</sup>, transport and energy demands of the Island. If the Island's energy strategy is right other kinds of policy tend to fall into place too.

(3) The States, like it or not, are involved in matters such as environmental standards, infrastructure investment, balance of payments and energy supply security. The present work has shown that energy has a direct and large impact in each one of these areas.

Even though the SEB continue to be the main source of public technical expertise relating to energy, they should not be identified as the arbiter of an energy strategy. The position presently held by the SEB derives rather from the need for a reliable electricity supply rather than any other considerations. It is important therefore that the States replace this with clear direction through the SOGEMS.

The matter of energy supply security is essentially THE important issue to very small islands; the availability of prime fuel at the Global level should therefore not be simply ignored. Oil reserves are uncertain and have been estimated at current rates of usage (with present prices)

1. Concern over the environmental importance of energy consumption provides a new and increasingly powerful argument for strategic energy conservation.

that the world may have about 45 years of oil reserves<sup>1</sup>; but there are lots of petroleum reserves available as price ramps upward<sup>2</sup>.

The real lesson would seem to be that oil and politics are still potentially highly unstable<sup>3</sup>; oil, always important, is the most highly politicised commodity in the world<sup>4</sup>. There will undoubtedly be future oil shocks, the only unknown is from which direction they will come.

A common reaction within the Island seems to be that renewable energy will offer a solution; the present work suggests that this seems to be unlikely.

There appear to be two views about what will happen as fossil fuel resources are depleted:-

(a) Queues at petrol stations, of rationing and transport gradually grinding to a halt.

(b) Prices going up owing to shortfalls in supply over demand.

1. See International Energy Agency, 1993, 'World energy outlook to the year 2010'.

2. Two thirds of the world's recoverable oil reserves are still controlled by a handful of nations in the Middle East and by the Commonwealth of Independent States.

3. See Cragg, C, 1990, '24 August: Crisis in the Gulf'.

4. See Sunday Telegraph, 30 September 1990, 'Who is getting rich from the oil crisis' or

Sunday Times, 12 August 1990, 'The crisis in the Gulf has pushed up oil prices and thrown world stock markets into turmoil'.



Both of which have already occurred on Guernsey during previous oil shocks. Left to the market (and no States intervention) as oil prices rose, the horticultural industry on the Island was decimated (see Section 2.2). The collapse of this sector vividly show that the States lacked and continue to lack a good energy strategy<sup>1</sup>.

The World Energy Council Commission<sup>2</sup> in 1993 reported the following key messages, which we should note:-

(a) It stresses the need for change now in the ways we currently provide and use energy in order to be able to meet future challenges successfully. Recognising the long time it takes to achieve change and the importance of using the years 1995-2020 as a key period of transition towards a more sustainable future.

(b) It points out that the present developing countries will account for 90% of world population growth, and at least 85% of the global increase in demand for energy services in the coming decades.

(c) It emphasises that the world population is expected to grow from 5.3 billion in 1990 to approaching 12 billion in 2100.

(d) It explains that the immediate worldwide priority is to

1. Industrial action in the docking and shipping fields have also shown the Island's vulnerability when considering factors outside its control.

2. World Energy Council Commission, 1993, 'Energy for tomorrow's world'.

raise the efficiency of energy provision and use.

(e) It suggests that there will be a need to place greater emphasis on local suitability.

(f) It believes that the supply of oil and natural gas is likely to be severely constrained by 2050 unless energetic steps are taken to improve efficiency.

(g) It says that although fossil fuels are expected to continue their dominance for the next few decades, even coal (despite its very healthy availability on current reserve/production ratios) could suffer constraints by 2100 if the necessary measures are not taken.

(h) It predicts that supply lines will lengthen and import dependency increase in the coming decades. The number of people dependent on imported energy is forecast to grow from 2.9 billion in 1990 to more than seven billion in 2020.

All of which suggest that the findings of the present work are appropriate and timely for the Island to now make its contribution.

(4) There is a need for an incremental approach to meeting parish energy growth at a rate broadly consistent with the QQT development within each parish.

The present centralised approach on Guernsey consider it dangerous to opt for less than maximum peak-demand 'plus' projections in order to avoid the risk of an energy supply shortfall (the possibility of surplus capacity is less

embarrassing than any energy shortage).

Traditional energy planning has been shown to waste resources (energy, capital, manpower) and has lead to:-

- (1) High end-user energy prices (see Section 4.4).
- (2) An appalling waste of heat energy and it is increasing (see Section 5.3).
- (3) Inflexible (centralised) large slow-speed diesel generators (see Section 7.6).
- (4) Lack of any real demand side energy efficiency improvements (see Section 8.3).
- (5) Air pollution (see Section 8.5).
- (6) A large (centralised) planning margin at the Vale power station (see Section 9.1).

These 'traditional' energy planning methods (that attempt to predict the future by extrapolating the past) do not prepare for a changing and uncertain future. New QOT tools are needed, but most important, a new way of thinking needs to emerge.

An incremental approach to energy service provision (where smaller (modular) cogeneration units can be added incrementally when required) would improve this situation. Producing greater diversity of supply, effectively equating to a distributed number of small parish based cogeneration stations, providing flexibility of response.

## 12.2 Strategic energy conservation

There is a need to be critical of all 'establishment' studies undertaken in the past on Guernsey<sup>1</sup> that do not question the present way of doing things. These studies usually only cover electricity and do not encompass the wider energy scene.

There has long been a contention of people working in the oil industry that there can be no such thing as a 'national' energy policy; that energy policy can only be an international affair (energy prices set internationally). In contrast, the present work has shown that very small (densely populated) islands CAN provide some isolation for themselves from the vagaries of such international oil markets. Strategic energy conservation is not necessarily a market response but needs to be an end in itself.

The old 'energy policy' argument that we should plan how the energy sector evolves over time sounds good, and simplistically comprised three elements:-

(1) A set of 'forecasts' of future conditions in the energy sector (but their general reputation for reliability has been poor).

1. For example Ewbank Preece Limited, 15 April - 10 May 1985, 'Brief review of the SEB's future energy policy options'.

To be fair, the report does mention that the heat rejected in present generation should be considered, but concludes that they believe they have considered all systems likely to have any significant impact on the energy policies of the SEB (not the Island).

The present work has shown that a more appropriate approach is to emphasise the importance of UNCERTAINTY (ie as in the Monte-Carlo method for example), INNOVATION (ie as with distributed cogeneration) and ENTREPRENEURSHIP (ie the energy service company idea).

(2) A set of 'objectives' to be pursued (but non-systemic attempts to formulate objectives appear to pull in different directions, refer to the discussion in Section 12.1).

(3) A set of 'instruments' for achieving these objectives (the instrument most widely used is that of price).

In contrast, the present work has shown that it may be possible for energy conservation to be achieved WITHOUT raising energy prices (and may be able to reduce them).

This old 'energy policy' argument does not consider the significant array of costs associated with the delivery of electricity to the final end-user from the centralised power station (see Section 4.3). Nor does it address the significant issue of reject heat from the centralised power station.

It is essentially important to question this and to also ask why island energy studies generally only relate to electricity production. 'The Jersey Energy Supply Study' by WS Atkins Management Consultants and Merz and McLellan<sup>1</sup> (of

1. Obtained from Addis, J.M, Committee Clerk, Policy and Resources Committee, Jersey, October 1991, personal communication.

December 1991) is a typical example of this usual approach on other islands. The title seems to convey an all-embracing energy remit for the island of Jersey but in fact is a report on how Jersey should meet its electricity requirements in the future.

Similarly on Guernsey, Ewbank Preece in January 1989<sup>1</sup> forecast (using the Island's past economic activity) that maximum electricity demand would rise to 79 MWe by the year 2000 and 97 MWe by the year 2010 (which also suggests the doubling of the present centralised heat energy loss). With the recommendation to further increase the centralised electricity generation capacity at the Vale power station (Guernsey's new 'D' power station).

**This concentration on merely providing electricity only is NOT a real energy study.**

When discussing energy matters, the main conclusion reached by the States in the 1991 Policy Planning, Economic and Financial Report<sup>2</sup> was:

"that the strategic issues that need to be considered are:-

(a) whether the Island should be so dependent upon oil or whether steps should be taken in the medium and long-term to lessen this dependence and

1. Ewbank Preece Limited, January 1989, 'Final report - Review of engineering development'.

2. See Billet d'Etat XVI, 1991, Wednesday 10 July 1991, (Section 7.4).

(b) how can the Island contribute in its own way to the more efficient use and management of energy, thus preserving natural energy reserves and reducing the emission of 'greenhouse' gases which are the cause of global warming ?".

The present work has provided systemic insights into both of these considerations.

With regard to the first, we have shown that if steps are taken in the longer term (30 years) to implement distributed cogeneration then this will significantly lessen dependence on oil imports. But the focus needs to be on energy service needs rather than the present 'prepared' energy fuels. The proposition of using less to produce more, both to conserve resources (energy, capital, manpower) and reduce waste, needs to be at the heart of this development strategy.

With regard to the second, we have shown that the Island can contribute in its own way to the management of energy by intervening directly into the energy market and implementing a formal 'States of Guernsey Energy Management System (SOGEMS)'. The imposition of legislation against atmospheric discharges should also be an important component of the SOGEMS 'Regulatory' sub-system.

The technical challenges that would arise from the implementation of distributed cogeneration have been mostly considered, confirming that systematic implementation makes sense. Its widespread implementation would fundamentally

change the way things are done on Guernsey.

The centralised power station at Vale (that has served the Island as the foundation of the electricity supply industry) would be replaced by a different concept, with a number of smaller (modular) cogeneration units (located much nearer the end-user). Our computer modelling suggests that it is only when there is a mix of production and domestic heat demands that 'customer use of waste heat' can be truly maximised. Location specific energy imbalances later confirmed this; it is only at the level of the parish where these different mixes of production and domestic consumption really occur and where attention is rightly focussed.

The SEB argue that it takes advantage of the economies of scale offered by centralised (large) slow-speed diesel generation plant to deliver power at lower cost<sup>1</sup>. The present work suggests that in terms of energy provision for the Island this may well be illusory. Required is a change from this centralised economy of scale of power production to distributed economies of mass production of power and ALSO heat.

The 'other benefits', which are not offered by the centralised power station at Vale, are a significant part of

1. The implementation of a centralised power plant is also encouraged by the fact that, because separate electric loads do not rise and fall in unison, the loads on central stations are much less sharply peaked than those in individual distribution areas. The present work suggests that this may not be such a dominant influence in the Guernsey clusters.



the value of distributed cogeneration and more than offset the high capital cost of parish heating networks.

It is not easy to square the aim of a secure and sufficient supply of energy for the Island, at a competitive price, with the aim of saving energy. The fundamental objectives of (a) cheaper energy for end-users (b) energy supply security and (c) environmental and health improvement however may just follow from the implementation of distributed cogeneration on very small (densely populated) islands such as Guernsey.

Modular cogeneration technologies, geographically dispersed but electrically interconnected, need to be at the heart of the strategy. Which runs counter to much current public energy policy in relation to utilities and supply-demand relationships.

### **12.3 From strategy to the tactics of action**

The energy market on the Island was shown to be worth in the order of £50 million at 1992 prices (see Chapter 5). This is almost a third of all States of Guernsey expenditure in 1992 and represents a significant controllable cost to the Island, which is not controlled at the Island level at present (unlike health services, social services, education etc). We have shown that by the imposition of the regulatory 'States of Guernsey Management System (SOGEMS)', petroleum product imports will be significantly reduced and will also bring 'other benefits' which are not provided by the present centralised approach.

To turn the aims and objectives of our research effort into practical action, an outline plan would be:-

- (1) To persuade parish end-users of the benefits of distributed cogeneration for the greater good of the Island<sup>1</sup>. Involving end-users in 'tariff setting' and 'greening' roles.
- (2) To implement statutory legislation for the SOGEMS (insular legislation is of two main types (a) Laws and (b) Ordinances, see Section 1.2), and set up a timetable.
- (3) To designate public sites owned by the States (within each parish) as the location of each ESCo (see Section 8.5).
- (4) To appoint the SOGEMS manager and staff<sup>2</sup>.
- (5) To undertake environmental impact studies.
- (6) To call for tenders for Contract Energy Management<sup>3</sup>

1. Parish end-user energy groups may be useful here, identifying local energy needs and priorities, informing local residents of progress, helping in implementation and channelling news, views and information.

2. Because at present there are existing employees in States Departments with the right sort of skills and experience, there is every reason to believe that each post can be filled by existing Islanders.

The manager of the SOGEMS is an important role.

3. Some CEM companies invest their own capital in projects (AES ENSTAR for example), others (BP ENERGY for example) do not invest their own capital but help to arrange finance. Both offer contracts with performance guarantees.

Inside Energy, August 1993, 'Outsourcing energy management' discusses the concept imported from America in the mid-1980s called Contract Energy Management (CEM): What it is and what it does.

For a comparison of different contract energy management types

(CEM) of each parish ESCo. With the CEM company (with energy management expertise and financing skills) offering to build, operate and maintain the parish ESCo. Possibly taking one parish (maybe St.Peter Port, which deserves important attention) as a test case.

Presently, there are only a handful of U.K. companies of any size that offer CEM, none of which really define CEM in quite the way that it is described in the present work<sup>1</sup>. CEM companies (through the SOGEMS) would compete for the award of a parish ESCo energy management contract.

(7) To set up a body to coordinate the planning and operation of the Island electricity network (which need not necessarily be the case for heating networks).

A restructured SEB (who already possess the skills to carry out the functions of this body) seem appropriate. Reliability, security of operation and maintenance is in no way reduced; reliability and security of operation in fact is enhanced (see Section 10.6).

(8) To implant an effective regulatory sub-system, with a necessary requirement to resist the temptation to focus on the short term objectives at the expense of medium and

...Continued...

see Tinson, R, January 1992, 'All you ever needed to know and more'.

1. CEM though is currently being applied in some of the most famous commercial companies on the U.K. mainland such as Ford, Nestle, Hoover, London Zoo etc.

longer term (30 year) strategic energy thinking.

Important is the formulation of this step-by-step plan of delivery in order to obtain public acquiescence of the concept.

Investors are looking for a good rate of return on their investment, with a high degree of security (which is what ESCos will provide). One of the things that helps get rates of return increased for private investors is tax incentives. If the States (through the regulatory sub-system) gives the money to the investors the project does not have to. Important also is that parish ESCos are not regulated to death, but provide CEM companies with a clear charter to ensure planning permits, road access etc (see Section 6.4).

Investors are looking for project security through proven technology (modular cogeneration), assured market demand and a legislative and regulatory environment that is friendly toward what they are trying to accomplish (energy service delivery). This is what the SOGEMS has to aspire to.

The Advisory and Finance Committee<sup>1</sup>:

"is of the view that the Island has now reached a point where more emphasis must be placed on long-term economic development projects as a key element in safeguarding the Island's economic future".

1. See Advisory and Finance Committee, 1992, '1992 Policy Planning, Economic and Financial Report'.

We have shown in the present work that distributed cogeneration should be a part of this long-term economic development. If it is not, the continued 'laissez faire' attitude by the States could again prove disastrous in economic terms.

#### 12.4 Further work

There seems to have been little published research on the topic of distributed cogeneration on very small islands. The only major 'distributed' research work presently being undertaken is by the Electric Power Research Institute (EPRI) of California. Who are investigating the impact of distributing electric only power stations on large electricity networks (which does not include cogeneration)<sup>1</sup>.

Their preliminary report<sup>2</sup> (which was issued in summer 1993) laid out a research agenda for detailed consideration of distributed 'generation' over the next five years. In contrast, the present work on Guernsey has *LOOKED* at a much smaller case study (equally valid) but includes the all important consideration of reject heat (a topic electricity utilities conveniently disregard). The further work necessary to extend our research effort is now considered.

1. Although EPRI have in the past considered large cogeneration plant, see for example EPRI, September 1980, 'Inclusion of cogeneration in electric utility models' and

EPRI, October 1981, 'Cogeneration and central station generation'.

2. See EPRI, 1993, Preliminary report TR - 102461, 'Distribution utility evaluation report'.

**The 'Regulatory' sub-system:**

The two most important sub-systems of the system ('Energy Market Analysis' and 'Energy Planning') have been operated here on paper. Further work is now required on the remaining two sub-systems, 'Regulatory' and 'Energy Planning Review'.

This will require the formulation of procedures for making regulatory decisions; developing acceptable ways of financially rewarding ESCOs for facilitating cost-effective demand side energy efficiency improvements; identifying and testing innovative energy conservation delivery and marketing approaches etc<sup>1</sup>. How market forces will yield any envisaged demand side energy conservation (and of what kinds of policy-assisted intervention may be required) need to be carefully thought out and tested.

Uneconomic parish ESCo projects could be implemented by the introduction of a subsidy from the savings of the system (via the SOGEMS). The question as to whether a subsidy should be paid to smooth out international oil market price variations<sup>2</sup> or reduce the capital cost of purchasing EVs (to encourage this form of transport for example), all need to be considered.

1. See Vine, E, De Buen, O, Goldman, C and Prah1, R, 1992, 'Mandating utility competition' for example.

2. See Guernsey Evening Press, 11 July 1979, 'Extra £2 million on growers fuel bill expected' or

Guernsey Evening Press, 19 February 1985, 'Cold adds 30¢ to growers fuel bills'.

The administration and formulation of the intervention 'package' for each parish (and the SOGEMS/ESCO and ESCO/end-user legal contracts) need to be quantified (the contracts specifying who pays what and what is deliverable).

Recommendations for this further work (in the form of Resolution Level 3 soft sub-system models) are provided in APPENDIX B. Which is a large (and separate) major task outside the provenance of this thesis.

**Improve the values given to benefits and costs:**

The present research effort has provided (and can only provide within the scope of the present work) budgetary estimates for cogeneration plant, heating networks and renewable sources. Further work is required to refine these estimates, but this should not significantly impact on our conclusion.

Each longer term (30 year) benefit (see Section 11.4) and cost (see Section 11.5) need to have their values improved. The true price of centralised and distributed energy (if the hidden costs<sup>1</sup> of airborne pollution could be truly identified for example) would also be worthy of further study.

The uneconomic renewables (in particular refuse burning and anaerobic (sewage) digestion) need to be considered in

1. See Lutz, E, 1993, 'Toward improved accounting for the environment' or

The Economist, 31 July 1993, 'The price of everything, the value of nothing'.

greater detail to assess the further financial benefits which may accrue. For example redirecting refuse away from future landfill sites in the first case and the implication of selling the nutrient rich fertiliser to the growing industry in the second.

**Transport energy usage:**

The additional energy savings that would accrue to the Island with the introduction of EVs into each parish has been considered. In addition to these savings, there may also be significant savings in noise and air pollution<sup>1</sup>, which may be a further reason for electric transportation (there are others; smooth demand curves for example, see Section 9.6).

A study to quantify the local noise and airborne pollution levels caused by motor transport on the Island is required<sup>2</sup>, but is not wholly relevant for the purposes of the present project.

**Provision of thermal storage:**

No provision has been made for thermal storage costs but this generally may have only a marginal effect, nevertheless the development of techniques for thermal

1. The pollutants produced by the motor car contribute significantly to global warming and acid rain.
2. Previous transport studies have really only considered traffic flows, see for example States of Guernsey, 1988, 'Transport study, Transport survey - Technical report' and States of Guernsey, 1988, 'Transport study, Transport survey - Survey report'.



storage are still required. Loading and unloading capacities of heat storage (including the use of thermally insulated heat-store accumulators) have been considered by a number of other researchers<sup>1</sup>.

**Capital equipment life-cycles:**

Others may care to consider the implication of cogeneration plant life-cycle cost differences on our findings. Any significant differences in life-cycle of the capital equipment may lead to a more subtle distinction between technological variants, but this needs to be tested.

**Behavioural:**

The proposed changes to the system may face heavy opposition from those with vested interests. Consideration of the reaction of the present oil companies on Guernsey to a reduction in petroleum product sales is one. The introduction of EVs and the reaction of the motor trade on the Island is another; there are others.

**12.5 Retrospective and failings of the research**

Our research has been overlaid onto a QQT 'template' approach to energy planning, with a greater emphasis on local (parish) suitability. Economic utilisation of degraded-quality (waste heat) energy is addressed by getting as much useful heat output from reject emissions as possible, through distributed cogeneration. In this way primary fuel inputs to heating are reduced, and hence fuel

1. See for example Fernandes, R, 1994, 'Cogeneration and energy storage systems at the distribution level'.

imports also.

Traditional Island planning methods are just not appropriate when approaching the energy conservation problem from a systems perspective. In 1991 the States themselves realised<sup>1</sup> that:

"There is still some work to be done in assessing who are the principal consumers of energy in the Island and where they lie in the economy. This information is necessary in defining the future importance of each industry and the effects of any growth policy (eg. the development of the visitor economy) on the demand for future energy consumption. As far as the States are concerned, this information is essential in identifying the increase in the use of electricity and what generating equipment needs to be planned".

The present research effort has attempted to provide all of this.

**There is a need for greater QQT data on each (and every) end-user:**

Our QQT evaluations have been used for meta modelling and scenario evaluations, where the possibility for integrating the requirement for electrical energy with the requirement for heat energy become much clearer.

Important is that Band 4 large end-users dominate energy demand in their locations. Each parish abstraction

1. See Billet d'Etat XVI (Section 7.18), 1991.

alone represents a significant proportion of the total electrical energy for production, and forms the bedrock of the electrical energy demand profile within each parish.

An elementary 'energy profile' database was formed using measured 'real' QQT demand profiles of each large end-user, within each economic sector, within each parish. For a thorough QQT energy planning analysis this is essential; actual site surveys are far more reliable than paper and pencil 'guesstimates'.

The results indicate that the timing profiles for end-users within the same economic sector are very similar. A ratio estimator was therefore used (with annual consumption as the auxiliary variable) to model six different levels of energy service delivery within a typical parish (Forest).

We have addressed Quality, Quantity and Timing issues but a far more detailed data collection of QQT characteristics of each (and every) parish end-user is justifiable in order to refine capital budgeting decisions. This could not have been attempted within the scope of the present work but will become the planning task of the parish ESCos.

**Disaggregated computer modelling:**

The work reported constitutes an important step in building disaggregated energy models, using actual site measurements.

Computer modelling in the present work served the

purpose of creating a 'bridge' between the 'Energy Market Analysis' sub-systems work described in Chapters 4, 5 and 6 and the 'Energy Planning' sub-systems work of Chapters 8, 9, 10 and 11.

The QQT site measurements provided the necessary disaggregate 'building blocks' for our model building. A set of reliable profiles are an essential requirement for thorough (QQT) energy planning, but more detailed diurnal heat analysis for each parish (with rather more real data than simulated) is required.

Excellent utility has been achieved from database and multi-page spreadsheets.

The parish models provided (a) an energy analysis combined with a financial analysis to select the size of modular cogeneration plant, (b) took into account renewable sources, involving stochastic processes (such as wind) and (c) selected supplementary heat boilers (again using stochastic processes). The simulation technique helped the results to come closer to an improved 'meta-reality'.

Both software and hardware are continually developing as part of an evolutionary process. For example 'Excel' has so many additional and different features, that it may make sense to do a little redesign of the Guernsey energy model to take advantage of these new features in the future.

**Subjective values and managerial positions:**

Facts alone cannot resolve controversy rooted in

subjective values and managerial positions (the advantages claimed for the benefits of scale for the large centralised power station at the Vale for example). Consideration of the 'Rich Picture' (see Figure 17) implies fragmented business interests and values. In contrast, the systemic approach adopted offers a near-optimal solution to Guernsey's energy problem and provided a means of exploring the 'richness' of the situation (which has not been explored before).

The way forward is determined by the resolution of ALL the elements of the rich picture. Our analysis deals with but a few of the most important relevant factors, but the issue that prompted the analysis in the first place (the preeminent aim of reducing petroleum products into the Island) is still the ultimate criterion. The security of supply of energy-form is particularly acute in the very small Island environment.

The distributed cogeneration concept is a radical reversal of principles that have governed the way the energy sector on Guernsey has developed over the years.

There have been recent circumstances that have affected the Island's energy situation, and that have focussed attention on this matter. The long term effects of global warming may be one, the recent Gulf crisis is another<sup>1</sup>. All of which should produce a positive reaction to the new concept (and the new energy management system that would

1. See Guernsey Evening Press, 15 August 1990, 'Anxious growers watch gulf'.

accompany it).

It requires (among others) the acquiescence of:-

- (a) States members.
- (b) Current fuel suppliers.
- (c) Energy pressure groups.
- (d) Parish end-users.

These quasi-political issues are not addressed in detail in the present work, and further attention needs to be given to them.

Nevertheless, unbiased and essentially accurate measurements/computer modelling, based in an actual case (Island) situation, reveals that in the future, the question should not be 'why distributed cogeneration'. But 'why did we produce electricity for so long on Guernsey with such an enormous loss of heat energy'.

#### 12.6 Chasing the virtuous circle

The present centralised approach does little to advance any kind of co-ordinated strategy for rationalising demand and factors of supply. The end-users are left to their own devices with little or no real sense of direction.

Centralised electricity production exists because:-

- (1) It was originally set-up at Vale to service the quarrying industry (see Section 1.1).
- (2) The SEB, with States ownership, have not been known for

their innovative responses.

(3) There has been a tendency for the SEB to reinforce its monopoly power.

(4) Ill-conceived infrastructure development (such as the introduction of the 33 kV electricity transmission network for example) has tended to reinforce itself.

This is not an attack on the SEB as such but questions the 'present way of doing things' on Guernsey.

Instead of continuing the present centralised development path, distributed energy planning is a powerful instrument in re-directing future development in a direction that reduces waste rather than increases it.

The rejection of cogeneration by the SEB may be due to insufficient analysis, arising from a preconceived notion of how the SEB should develop<sup>1</sup>. It appears that they have been preoccupied with generating electricity with centralised (large) slow-speed diesel units.

The challenge for the States is now to redirect this preoccupation and centralised interests of the Island energy market. Their role is critical, because it is the role of the States which has so far prevented strategic energy conservation from happening, but do they know this ?

1. From 1964 to 1990 primary energy losses have increased threefold and continue to increase (see Section 5.3).

The benefits revealed by our meta-modelling approach cannot be ignored, it indicates that an opportunity may well be being missed in making better use of the Island's resources.

Distributed cogeneration represents a fundamental change from the supply of 'prepared' fuels to a culture of energy service provision. The upheaval would be great, the parish ESCos represent extremely new thinking and there would be many people to convert to an entirely new energy concept.

Strong reinforcement of energy conservation through distributed cogeneration would limit growth in energy demand. Drive down the present inefficient use of energy and significantly reduce prime fuel imports into the Island in the future.

We are thus proposing a 'virtuous' circle of activities to replace the current 'profligate' one. The States of Guernsey should now be setting the 'energy environment' through the SOGEMS, with the regulated parish ESCos contracted to achieve demand side energy savings. The States involvement is needed only in passing the necessary legislation to form the SOGEMS themselves, parish ESCos and market criteria would apply thereafter.

The present situation is consistent with the interests of the SEB, distributed cogeneration would be more consistent with parish concerns at the local level.



The ESCo would then be a 'single window' agency and implement all components of demand side energy efficiency programmes; provide information; assess requirements; financing; organise contractors and capture the full economic potential for demand side energy conservation.

The present work has shown that there are good reasons for very small islands to chase this 'virtuous' circle (with the manager of the SOGEMS driving the circle). No-one is looking at it in a systemic way at the moment, and this needs to be changed.

The provision of energy services on Guernsey may be done better distributed than centralised<sup>1</sup>; which appears to be opposite to presently held opinion<sup>2</sup>.

The usefulness of Guernsey as a project base lies beyond any consideration of its relative size and importance. It is a functional model of a small island economy that can be replicated elsewhere, including local schemes within the U.K. mainland. Areas of high population

1. European Union definition of subsidiarity: Doing things together (centralised) only if you can do them better that way than separately (distributed).

2. Letter to the President, States of Guernsey, Royal Court House, St. Peter Port from the President, Advisory and Finance Committee, 20 August 1990:

(1) It is essential that, in the economic and social interests of the Island, the centralised electricity generating capacity be renewed and extended.

(2) No practical alternative presently exists.\*

See Billet d'Etat XVI 1990, Wednesday 26 September 1990.

density may prove to be very similar in nature, and it may therefore be feasible for the energy saving outcomes of the present work to be transferred to other larger (densely populated) areas. However, on a larger scale (with no 'island' boundaries) such outcomes may be even more difficult to quantify.

Politically, one problem is that, as soon as States members hear the term 'energy efficiency', they believe that money needs to be spent and that it could have an effect on the budgets of their committees, on their political careers and on the economy of the Island. Regardless the present work has indicated that this need not be the case.

The energy pricing levels produced by changing the system should not result in the aggravation of the economic and social conditions within the Island. These may be enhanced, with greater security of supply, greater diversification and lower air pollution.

A States politician may appreciate this call for change but oppose it nevertheless if it appears to threaten the underlying consensus. The underlying consensus on Guernsey (and also on other very small islands) is for centralised 'prepared' fuels. Historically it is the norm, but we have demonstrated that it is wasting resources.

The relinquishing of decisionmaking powers by the States (whether intentionally or unintentionally) to those presumed to have special competence (ie. with a specific discipline) is of concern. Delegating decisions to

the SEB management or to other managerial groups might (in some circumstances) run the risk of being manipulated.

A systemic view of Island energy has been shown to be multi-disciplined. The major problem faced has been shown to be one of lack of strategic energy management rather than of engineering experience.

We have addressed the question 'Do we expand the present Island supply of fuels and electricity, or do we instead use less fossil fuels to meet the energy services we want by other means, at lower cost?'. We have shown that distributed cogeneration may be a real economic alternative to expanding centralised electricity generation.

Diversity of fuel supply is often regarded as a crucial strategic issue, but on remote, very small islands with no indigenous energy resources you cannot have everything<sup>1</sup>. The less oil imports the Island needs the greater the security and the less vulnerable it is to circumstances outside its control.

Sudden price rises and scarcity of supply are important considerations. With the implementation of distributed cogeneration the existing oil stock would represent some three months more usage, which would provide secure and adequate fuel reserves to deal with unforeseen circumstances outside the Island's control (ie. strategic storage).

1. But in U.K. mainland clusters this may not be the case.

Uncertainty about an energy-deficient world economy was of great concern on Guernsey in the 1970s, but this has faded from memory through the 1980s and early 1990s. **The problem is still there.** The present work has attempted to explore this complex unstructured energy problem in order to prepare for the next shock. Important, is that the cost of this increase in security (when compared with the present way of doing things) may be negligible.

A full knowledge of the present scale of - AVOIDABLE - fuels waste has been attempted. The analysis is an appeal to reason and attempts to communicate ideas and systemic insights.

**APPENDICES**

**APPENDIX A**

### Energy measurement

There is currently only one internationally accepted method of energy measurement which is based upon the JOULE<sup>1</sup> (and its attendant multiples, such as the megajoule [MJ] and gigajoule [GJ]). A further unit which is scientifically acceptable is the kWh, which we use in the present work.

Supply and demand of prime fuel energy is expressed in kW; energy uses for delivered fuels and electricity in kWh.

The calorific value of the various types and sources of coal, oil etc vary widely. The following equivalents have been used:-

	kWh/Litre
Petroleum products	10.6
Coal	7,480.0
LPG	13,726.0

	Litres/tonne
Kerosene	1234
Gas Oil	1184
HFO	1059
Motor Spirit	1353
Avgas	1415
Avtur	1234
LPG	1846

1. In his celebrated experiments, Joule demonstrated the conversion of mechanical work and electrical energy into heat (Faraday demonstrated that mechanical work and electrical energy could be converted one into the other). From these pioneering experiments there came the perception of energy appearing in many guises, as something always conserved, and by appropriate means could be changed from one form into another.

**Symbols and units used**

k	kilo	thousand	(10 <sup>3</sup> )
M	Mega	million	(10 <sup>6</sup> )
G	Giga	thousand million	(10 <sup>9</sup> )

P	Power	Watt
We	Electrical power	Watt
Wt	Heat power	Watt

1 Watt = 1 Joule/second



**APPENDIX B**

Resolution Level 3

'Energy Market Analysis' sub-system models

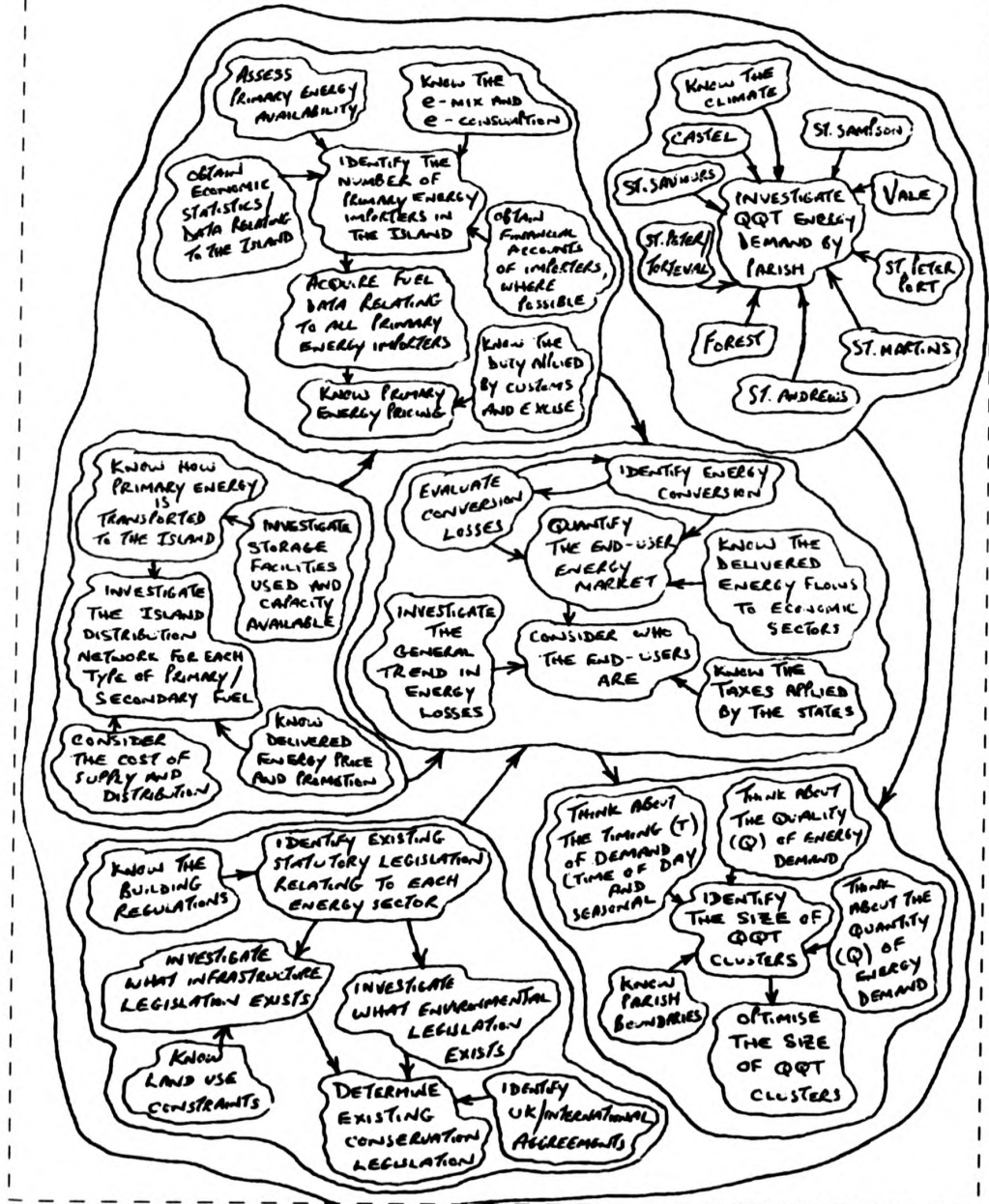

Resolution Level 3

'Energy Market Analysis' sub-system models

Figure 140

Resolution Level 3  
'Energy Planning' sub-system models

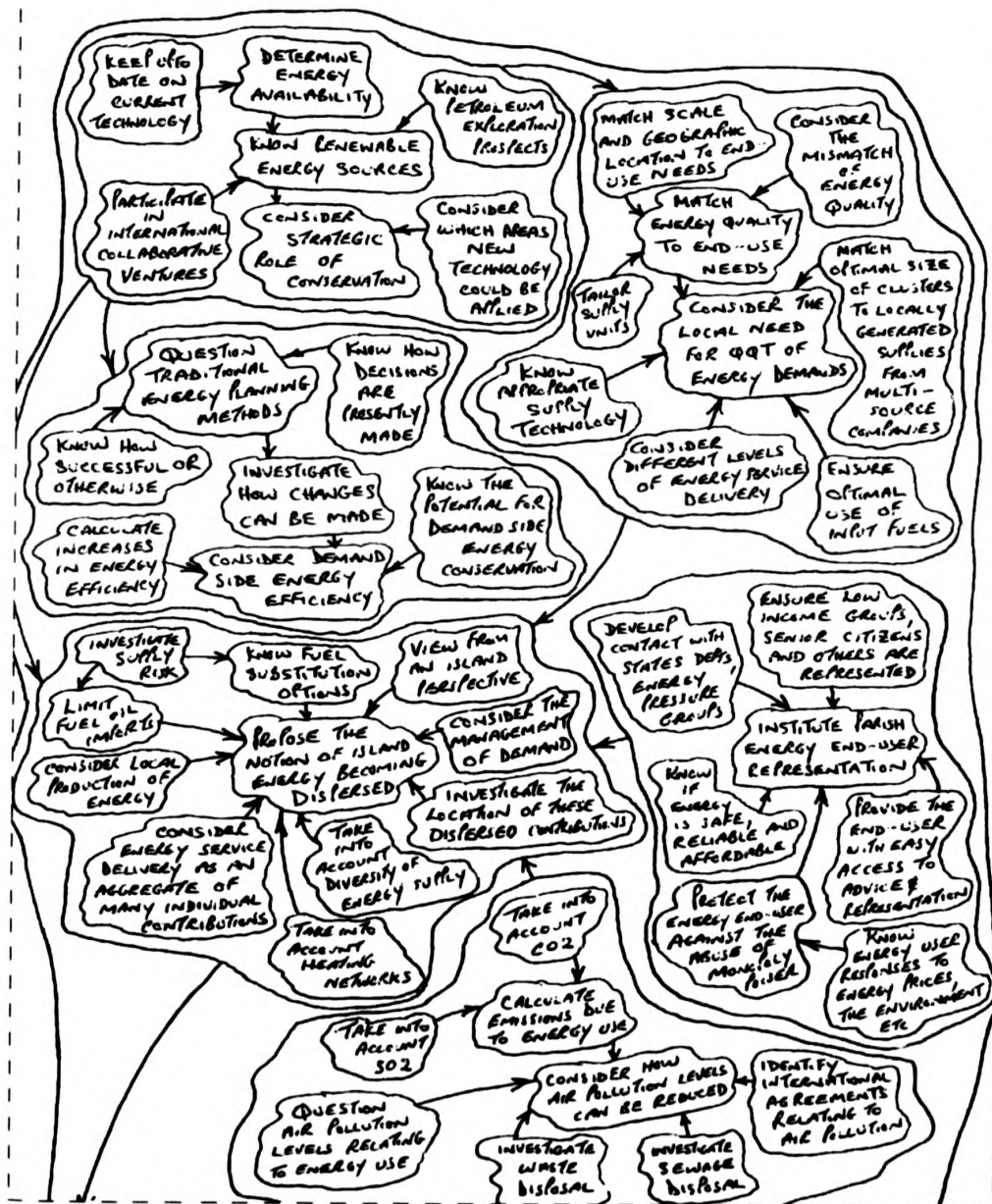

Resolution Level 3  
'Energy Planning' sub-system models

Figure 141

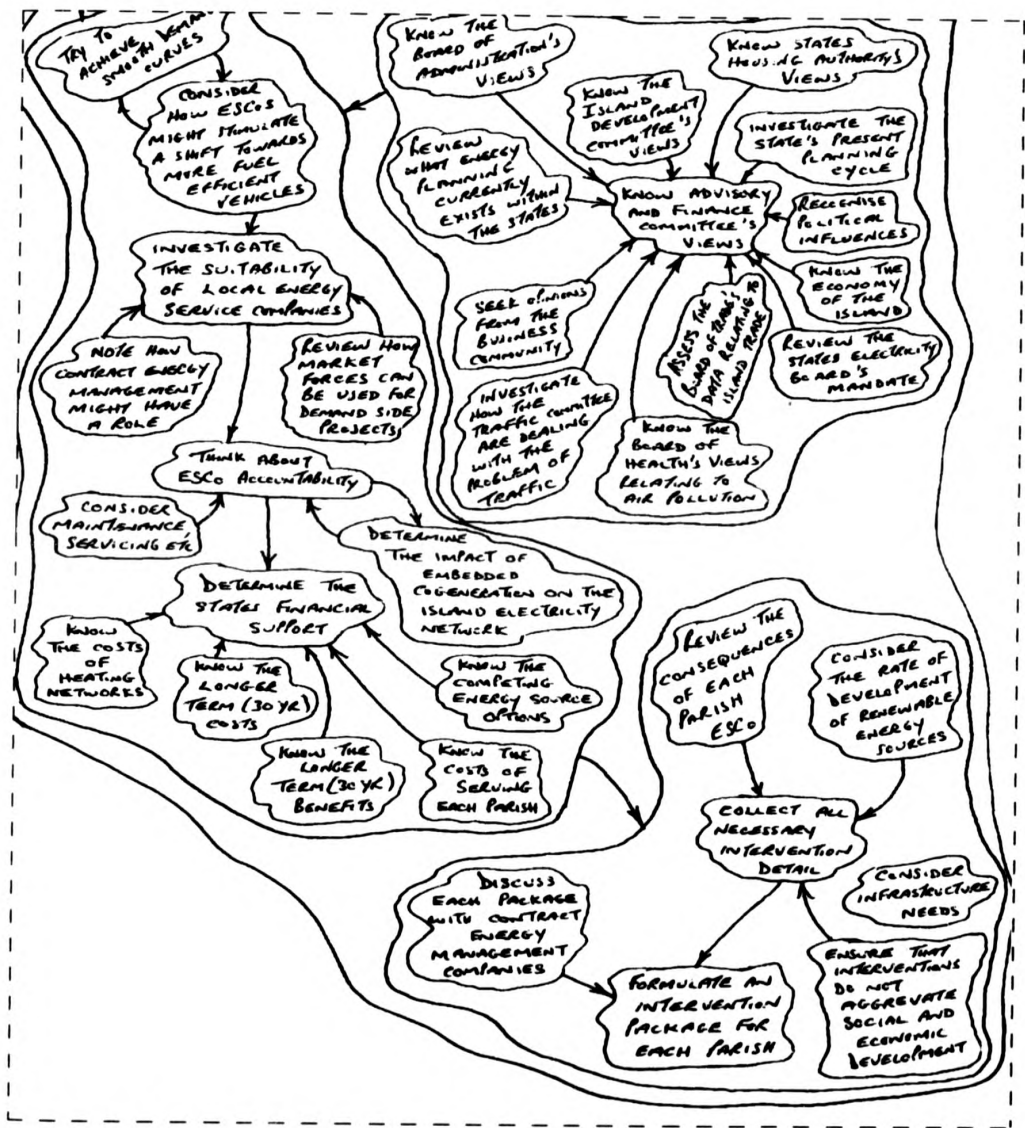

Resolution Level 3  
'Regulatory' sub-system models

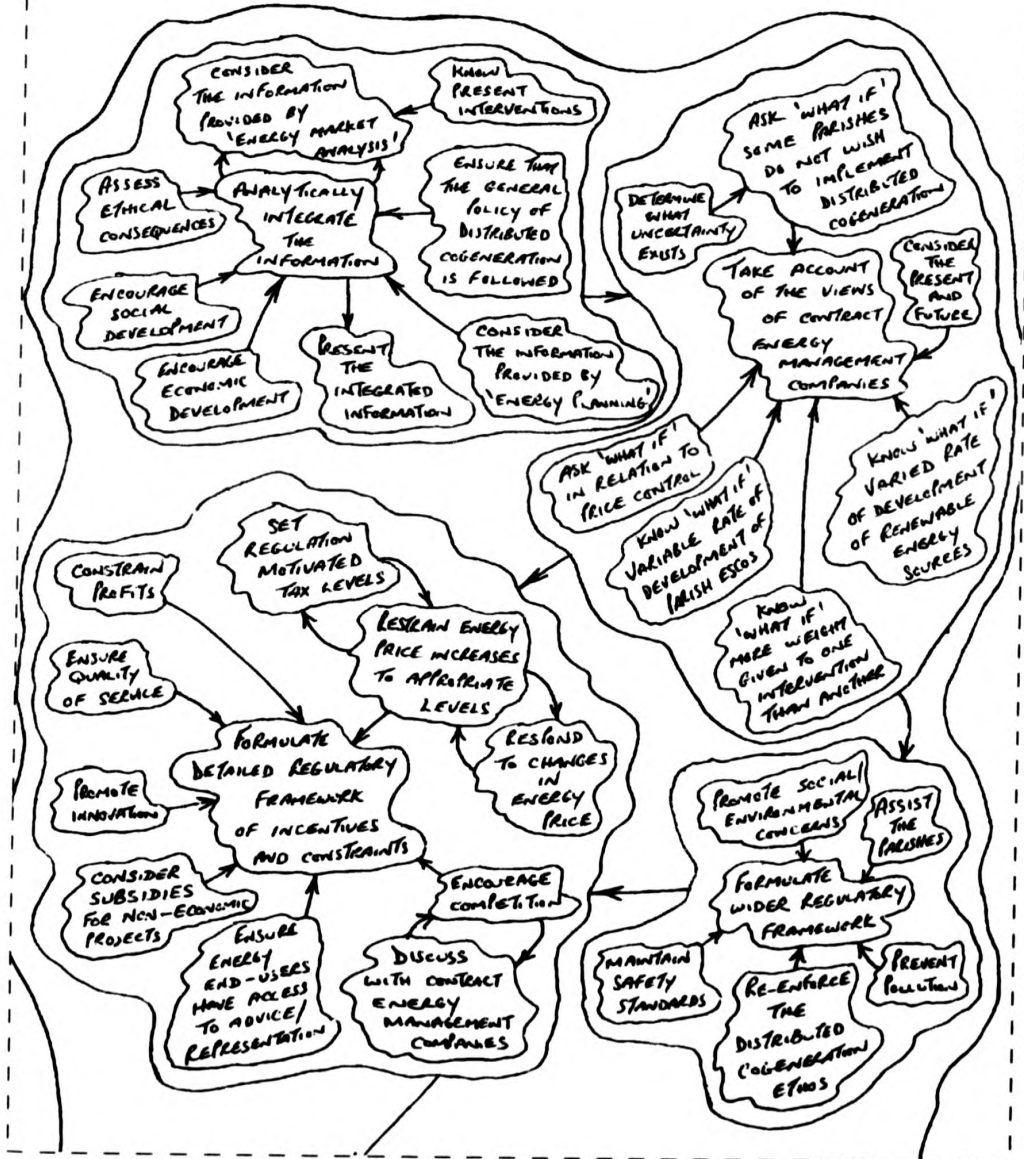

Resolution Level 3  
'Regulatory' sub-system models

Figure 142

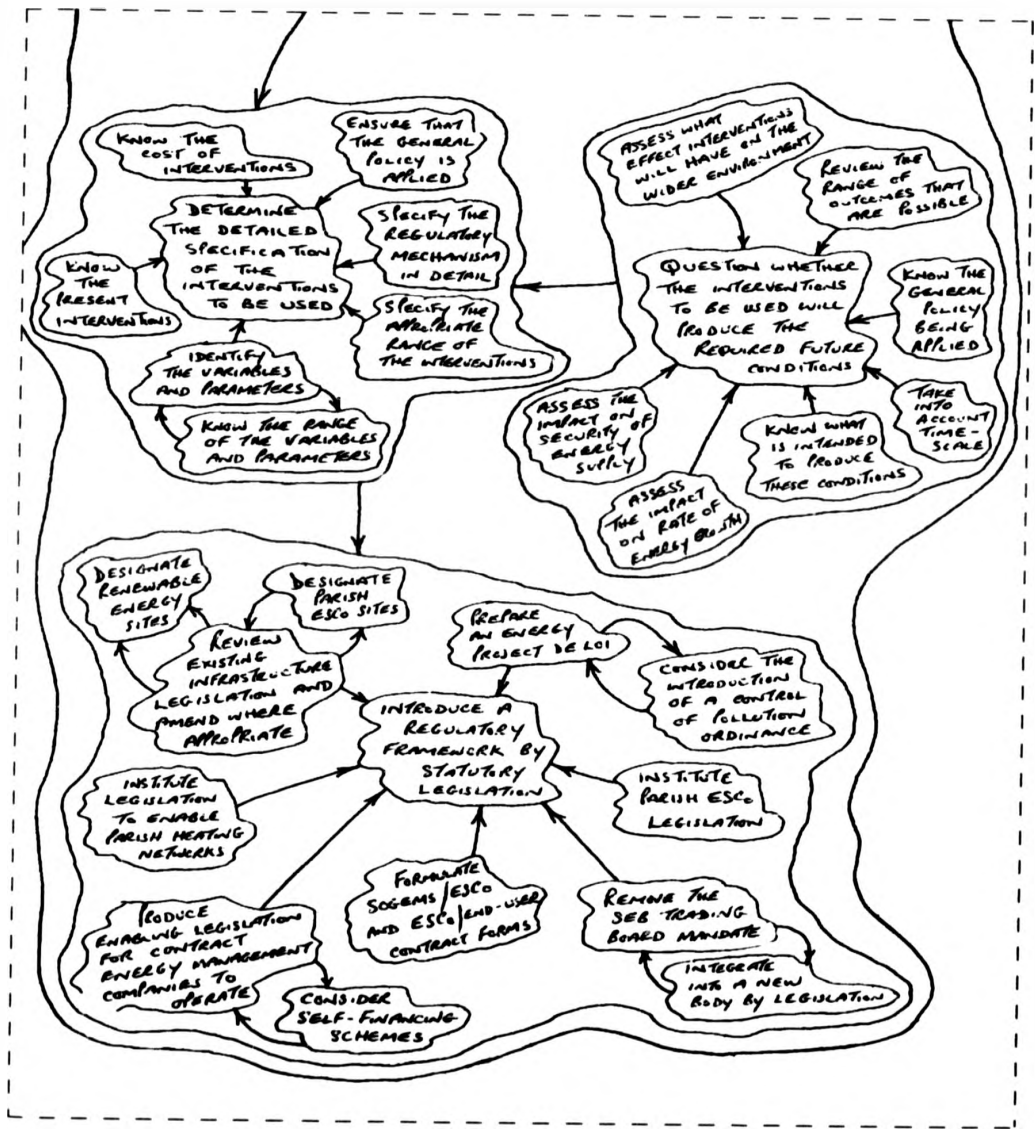



Resolution Level 3  
'Energy Planning Review' sub-system models

Figure 143

**APPENDIX C**



## Parish band four energy end-users

### The parish of Vale

The 26 band four end-users comprise 15 commercial, 2 tourism, 6 industrial and 3 vineries. The largest annual electricity end-users in each sector are:-

Comm./p.bldgs	- Alliance cash & carry supermarket	0.7 GWe
Tourism	- Peninsula hotel (renamed Novotel)	0.6 GWe
Industrial	- States Water Board (Juas Quarry)	1.2 GWe
Vineries	- Vingtaine vinery	0.3 GWe

Figures 144, 145, 146 and 147 provide their daily electricity demand profiles.

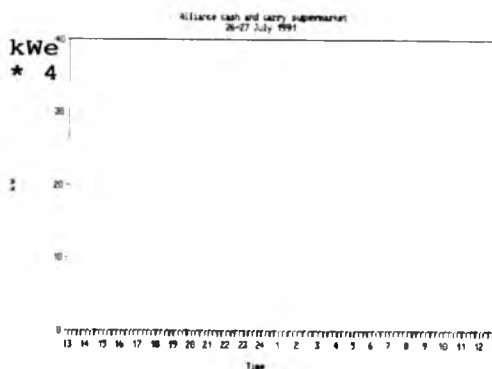

**Alliance cash and carry  
(supermarket)**

**Figure 144**

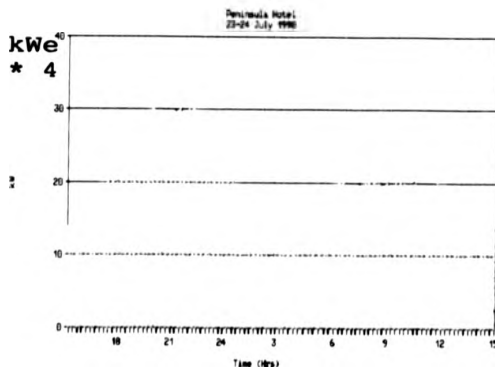

**Peninsula hotel**

**Figure 145**

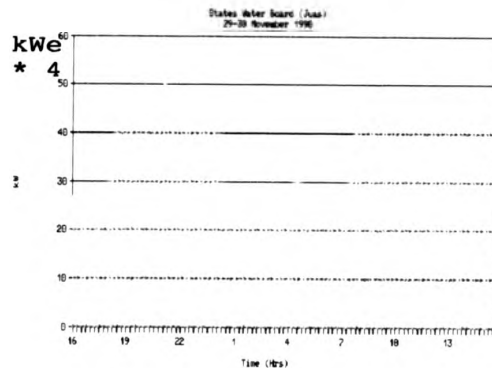

States Water Board  
(Juas Quarry)

Figure 146

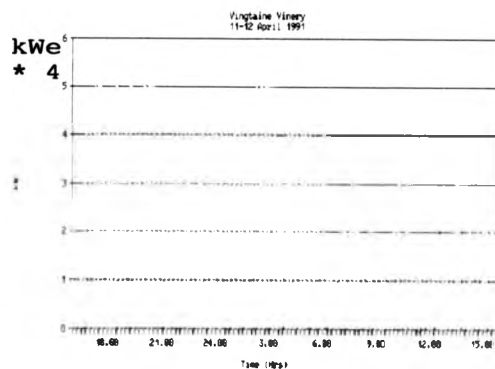

Vingtaine vinery

Figure 147

#### The parish of St.Sampsons

The 33 band four end-users comprise 19 commercial, 8 industrial and 6 vineries. The largest annual electricity end-users in each sector are:-

Commercial/p.bldgs	- States Prison	0.3 GWe
Tourism	- None	
Industrial	- Ronez Ltd (Les Vardes Qry)	1.2 GWe
Vineries	- Kenilworth vinery	0.4 GWe

Figures 148, 149 and 150 provide their daily electricity demand profiles.

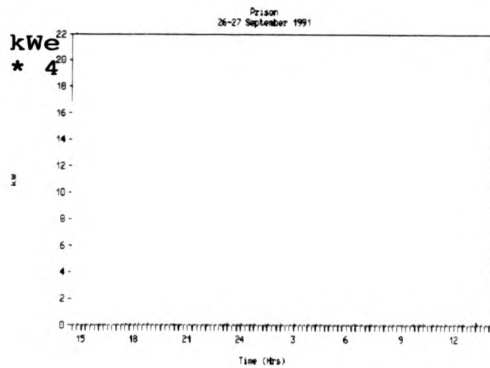

**States Prison**

**Figure 148**

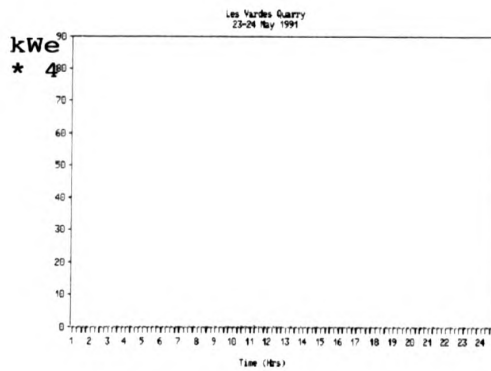

**Ronez Ltd  
(Les Vardes Quarry)**

**Figure 149**

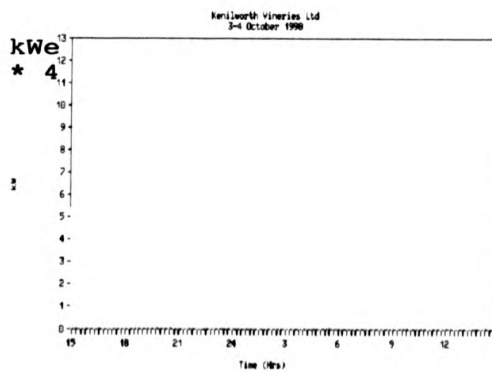

**Kenilworth vinery**

**Figure 150**

**The parish of Castel**

The 25 band four end-users comprise 13 commercial, 6 tourism and 6 industrial. The largest annual electricity end-users in each sector are:-

Commercial/p.bldgs	- King Edward VII Hospital	0.7 GWe
Tourism	- Hougue du Pommier Hotel	0.2 GWe
Industrial	- States Water Board (K. Mills)	0.4 GWe
Vineries	- None	

Figures 151, 152 and 153 provide their daily electricity demand profiles.

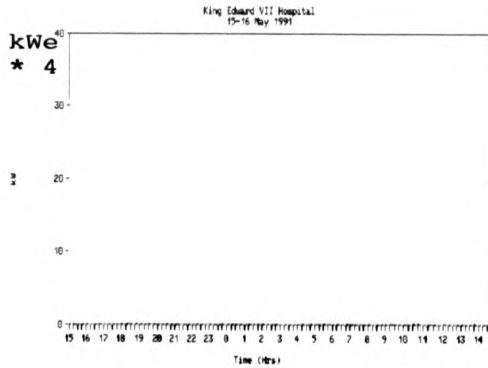

**King Edward VII  
(Hospital)**

**Figure 151**

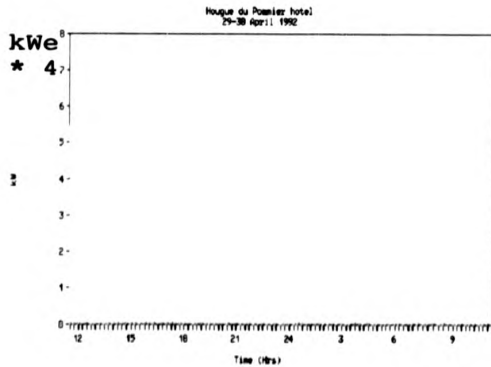

**Hougue du Pommier Hotel**

**Figure 152**

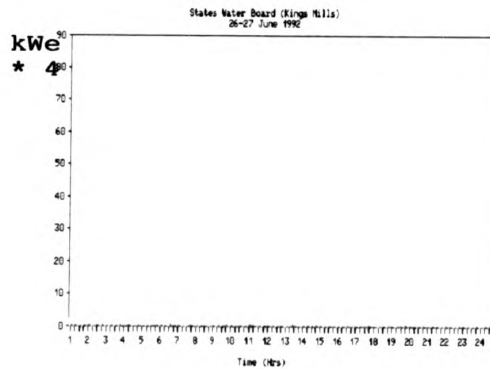

**States Water Board  
(Kings Mills)**

**Figure 153**

**The parish of St.Saviours**

The seven band four end-users are:-

Commercial/p.bldgs	- Warry & Sons (Bakery)	0.1 GWe
	- States Water Board	0.1 GWe
	- Mont Variouf School	0.1 GWe
Tourism	- Hougue Fougue Hotel	0.1 GWe
	- Atlantique Hotel	0.2 GWe
Industrial	- SWB (dam/reservoir)	1.1 GWe
Vineries	- Les Mourants vinery	0.1 GWe

Figures 154, 155, 156 and 157 provide the daily demand profiles for the largest end-user in each sector.

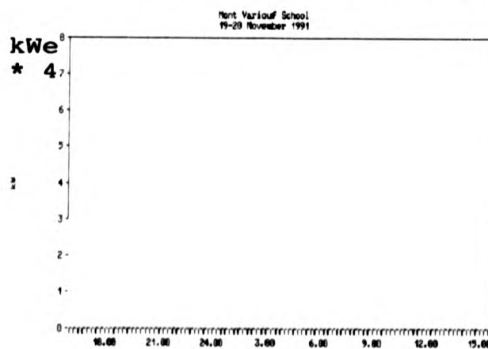

**Mont Variouf School**

**Figure 154**

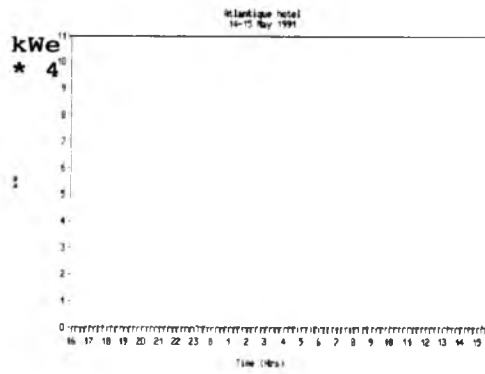

**Atlantique Hotel**

**Figure 155**

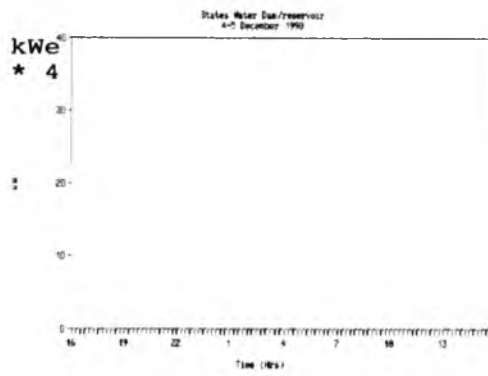

**States Water Board  
(Dam/reservoir)**

**Figure 156**

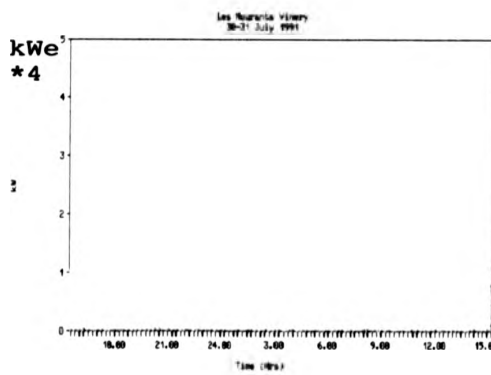

**Les Mourants vinery**

**Figure 157**

**The parish of St.Peter/Torteval**

The seven Band four end-users are:-

Comm./p.bldgs	- Le Riche Stores	0.2 GWe
Tourism	- New Passiflora Hotel	0.1 GWe
	- Longfrie Hotel	0.1 GWe
	- Imperial Hotel	0.1 GWe
Industrial	- None	
Vineries	- Sandpiper Nurseries	0.1 GWe
	- Bader Roses	0.4 GWe

Figures 158, 159 and 160 provide the daily electricity demand profiles for the largest end-user in each sector.

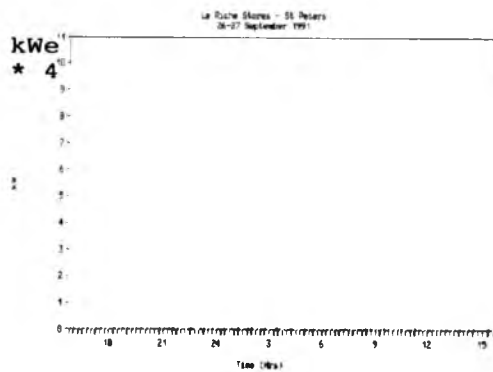

**Le Riche Stores**

**Figure 158**

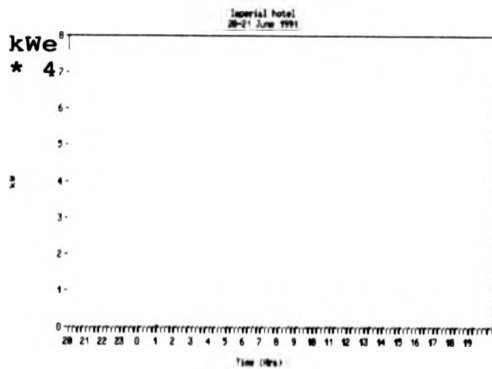

**Imperial Hotel**

**Figure 159**

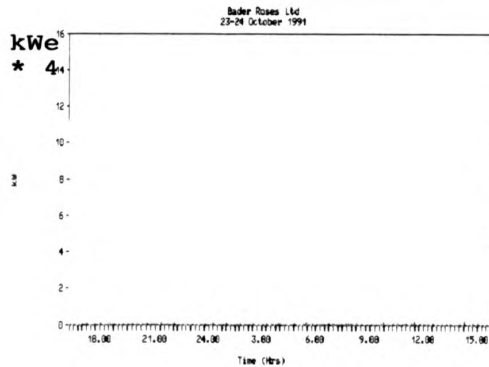

**Bader Roses**

**Figure 160**

**The parish of Forest**

The eight Band four end-users are:-

Commercial/p.bldgs	- Forest road garage	0.1 GWe
	- States Water pumping stn.	0.1 GWe
	- Forest stores	0.2 GWe
	- States Airport	1.7 GWe
Tourism	- Manor Hotel	0.1 GWe
	- Mallard Country Club	0.2 GWe
Industrial	- None	
Vineries	- Homefield	0.2 GWe
	- Sovereign Flowers	0.7 GWe

Figures 161, 162, 163 and 164 provide the daily electricity demand profiles for the largest end-user in each sector.



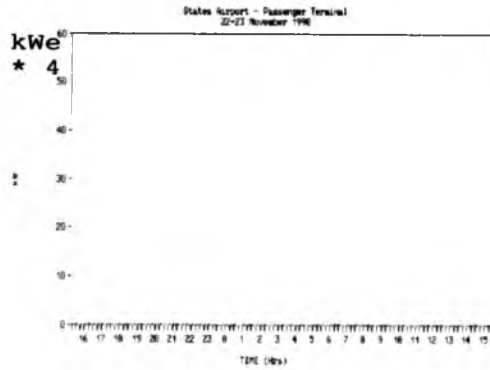

**States Airport  
(Passenger Terminal)**

**Figure 161**

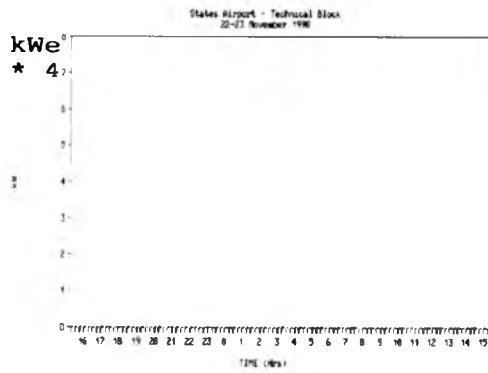

**States Airport  
(Technical Block)**

**Figure 162**

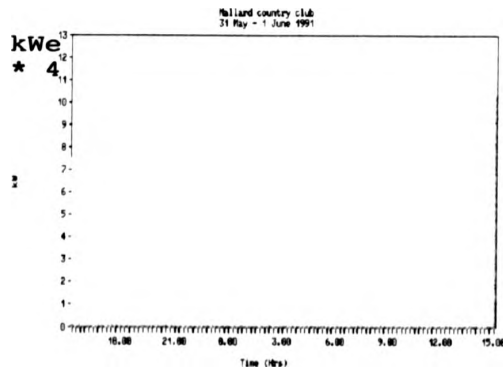

**Mallard Country Club**

**Figure 163**

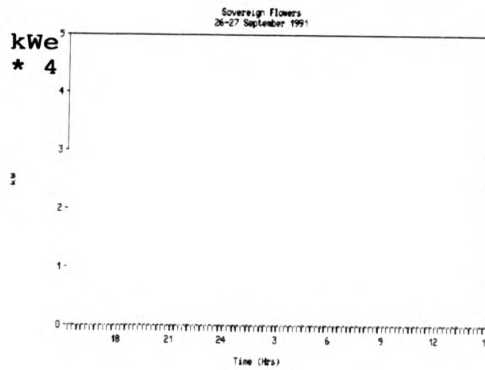

### Sovereign Flowers

Figure 164

#### The parish of St. Andrews

The seven Band four end-users are:-

Commercial/p.bldgs	- Rohais chip shop	0.1 GWe
	- Grammar School	1.0 GWe
Tourism	- None	
Industrial	- Ronez Ltd	0.1 GWe
	- States Dairy	0.7 GWe
(Left the Island)	- Tektronix	1.6 GWe
Vineries	- Virgin Flowers	0.1 GWe
	- J. Angenent Roses	0.2 GWe

Figures 165, 166, 167, 168 and 169 provide the daily electricity demand profiles for the largest end-users in each sector.

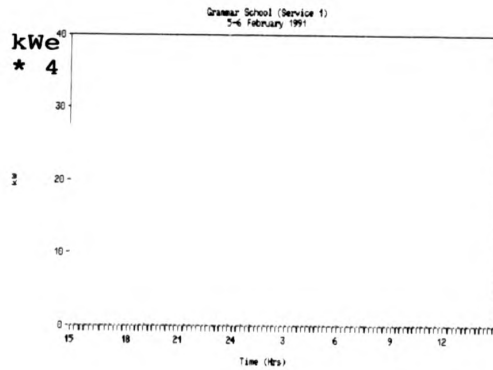

**Grammar School  
(Service 1)**

**Figure 165**

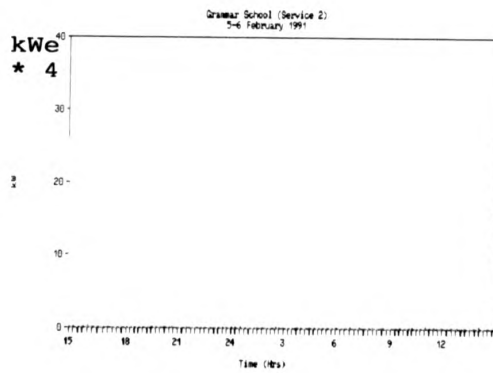

**Grammar School  
(Service 2)**

**Figure 166**

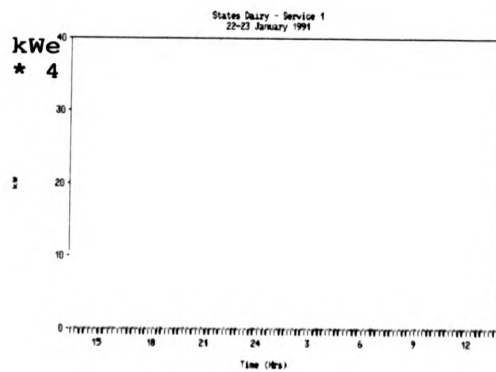

**States Dairy  
(Service 1)**

**Figure 167**

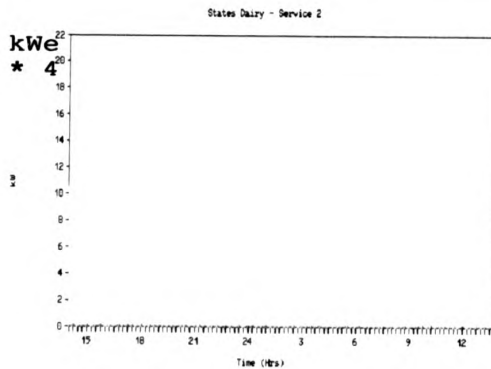

**States Dairy  
(Service 2)**

**Figure 168**

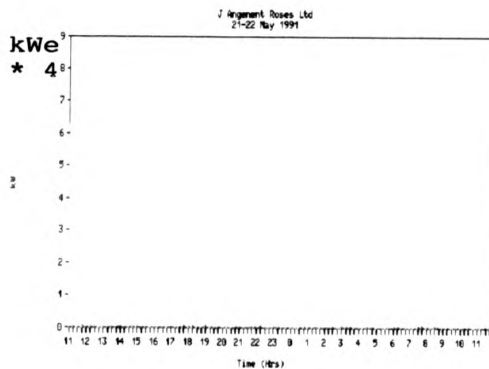

**J. Angenent Roses**

**Figure 169**

**The parish of St. Martins**

The 32 Band four end-users comprise 16 commercial, 15 tourism and 1 vinery. The largest annual electricity end-users in each sector are:-

Commercial/p.bldgs	- Princess Elizabeth Hosp	1.8 GWe
Tourism	- St. Margarets Lodge hotel	0.3 GWe
Industrial	- None	
Vineries	- Bali-Hai	0.4 GWe

Figures 170, 171, 172 and 173 provide their daily electricity demand profiles.

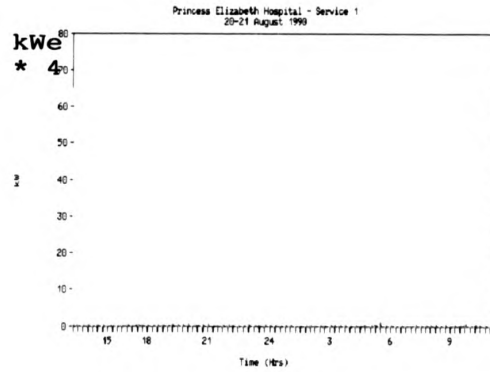

**Princess Elizabeth Hosp  
(Service 1)**

**Figure 170**

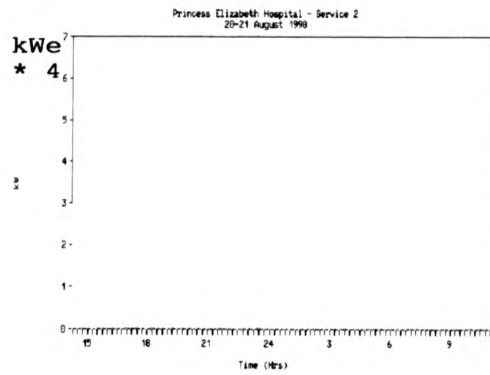

**Princess Elizabeth Hosp  
(Service 2)**

**Figure 171**

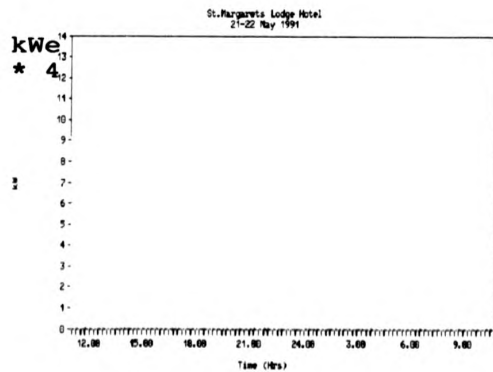

**St. Margarets Lodge Hotel**

**Figure 172**

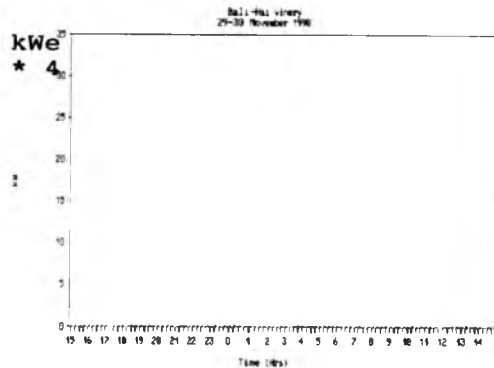

**Bali-Hai vinery**

**Figure 173**

**The parish of St. Peter Port**

The 130 Band four end-users comprise 96 commercial, 22 tourism, 10 industrial and 2 vineries. The largest annual electricity end-users in each sector are:-

Commercial/p.bldgs	- Beau Sejour	1.5 GWe
Tourism	- St. Pierre Park hotel	1.5 GWe
Industrial	- Intersurgical	1.0 GWe
Vineries	- Ramee Roses	0.3 GWe

Figures 174, 175, 176, 177, 178 and 179 provide their daily electricity demand profiles.

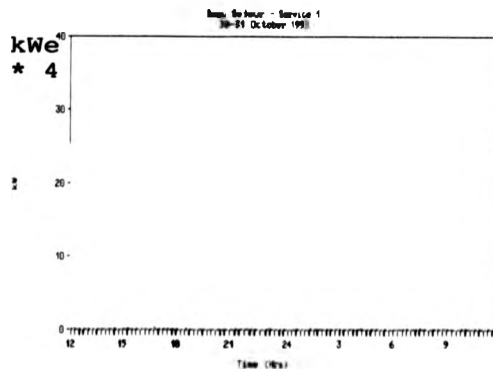

**Beau Sejour  
(Service 1)**

**Figure 174**

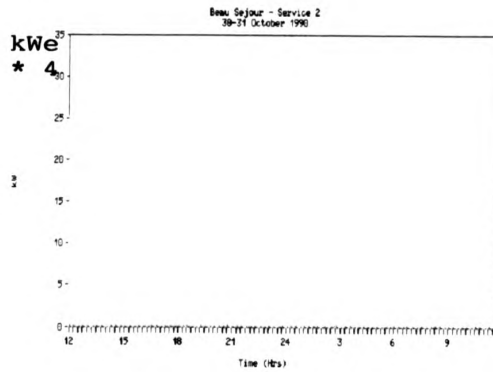

**Beau Sejour  
(Service 2)**

**Figure 175**

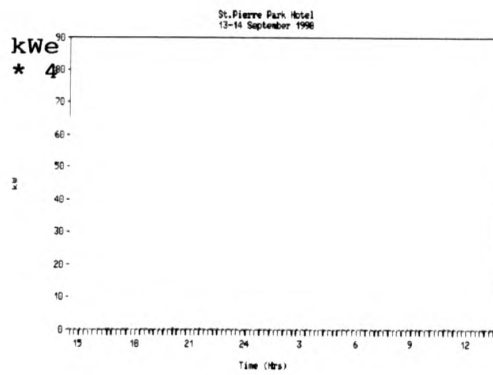

**St. Pierre Park hotel**

**Figure 176**

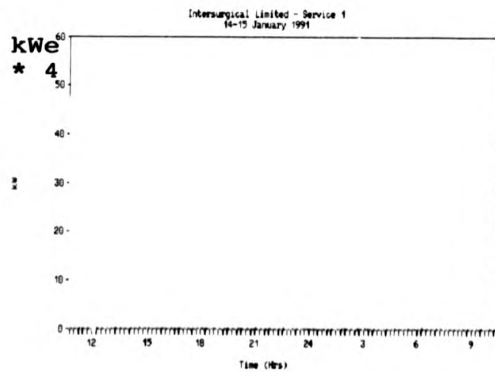

**Intersurgical  
(Service 1)**

**Figure 177**

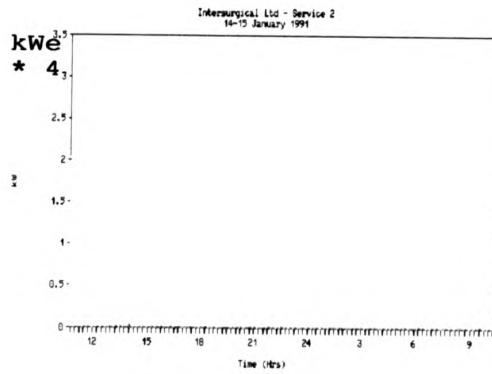

**Intersurgical  
(Service 2)**

**Figure 178**

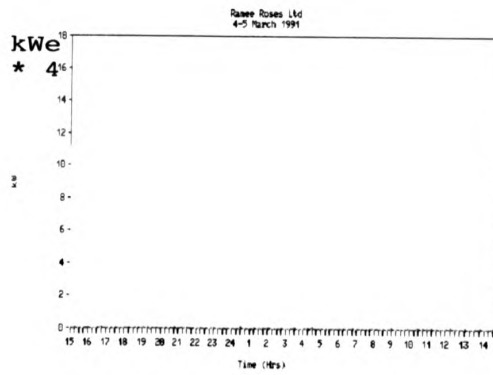

**Ramee Roses**

**Figure 179**



**APPENDIX D**

### Support environments and graphical techniques

#### Large internal memory portables:

The computer based energy modelling on Guernsey was produced on a Tandon 386SX Notebook computer, 40 Mb Hard Disk drive, 10 Mb RAM using MS-DOS 5.

#### High-level language-like programming environments:

The Guernsey energy model uses dBASE III Plus (Ashton-Tate), which is a relational database and also a programming language; compiled under 'CLIPPER' (Nantucket).

The use of multi-page spreadsheets with their macro languages now permit extensive applications (eg. iterative calculation, embedded macros and other features). SuperCalc 5 (Computer Associates) was used in the present work for parish energy model building.

#### Graphics:

Use was made of Harvard Graphics (Software Publishing) to build 2D and 3D charts/images and Autosketch (Autodesk) for drawings and maps. A Geographic Information System (Alper Systems), operated by the States Electricity Board, was also used to produce map backgrounds (via appropriate Unix/MS-Dos file transfer routines) from their digitised map base of the Island.

**APPENDIX E**

Guernsey energy model source code programs  
(PhD.prg, PhD00 - PhD60.prg)

```

*:*****:
*:
*:      Program: PhD.prg
*:
*:      Title: Guernsey energy model
*:      Writer: Derrick Fielden
*:      Copyright (c) 1995, Derrick Fielden
*:
*:      Calls: PhD00.prg - Meta modelling
*:
*:      Uses: SuperCalc 5 advanced spreadsheet modelling
*:             : dBASE III PLUS database/programming language
*:             : CLIPPER compiler
*:
*:*****:
CLEAR ALL
SET DATE BRITISH
SET COLOR TO W/B,W/B,,,W/B
SET TALK OFF
SET INTENSITY OFF
SET DELIMITER TO "[ ]"
SET DELIMITER ON
CLEAR
TEXT

                Derrick Fielden

                PhD - University of Stirling

                *****

                Energy Modelling

                The Island of Guernsey

                Copyright (c) 1995

ENDTEXT
now = VAL(SUBSTR(TIME(),7,2))
IF now < 50
    muntil = now + 5
ELSE
    muntil = now + 5 - 55
ENDIF
t1 = 0
DO WHILE t1 <> muntil
    t1 = VAL(SUBSTR(TIME(),7,2))
ENDDO
SET HEADING OFF
PUBLIC mquote
mquote = '''
DO WHILE .T.
    CLEAR

```

```
DO PHD00
EXIT
ENDDO
RETURN
```

```
*: EOF: Phd.prg
```

```
*:*****:
*:
*:      Program: PhD00.prg
*:
*:      Title: Meta modelling - Scenario evaluation
*:      Writer: Derrick Fielden
*:      Copyright (c) 1995, Derrick Fielden
*:
*:      Calls: Phd10.prg - Introduction
*:             : Phd20.prg - Parish clusters
*:             : Phd30.prg - Final parish models
*:             : Phd40.prg - Energy and financial analysis
*:             : Phd50.prg - Simulation
*:             : Phd60.prg - 30 year life-cycle ESCos
*:
*:      Uses: SuperCalc 5 advanced spreadsheet modelling
*:            : dBASE III PLUS database/programming language
*:            : CLIPPER compiler
*:
*:*****:
```

```
CLEAR ALL
SET DATE BRITISH
SET COLOR TO W/B,W/B,,,W/B
SET TALK OFF
SET INTENSITY OFF
SET DELIMITER TO "[ ]"
SET DELIMITER ON
CLEAR
```

```
SET HEADING OFF
PUBLIC mquote
mquote = '"'
DO WHILE .T.
  CLEAR
  TEXT
```

**Meta modelling  
- Scenario evaluation**  
-----

1. Introduction
2. Parish clusters
3. Final parish models
4. Energy and financial analysis
5. Simulation
6. 30 year life-cycle ESCos

\*. Exit

```
ENDTEXT
```

```
@ 2,20 TO 21,55 DOUBLE
@ 23,0
ACCEPT 'Make your selection.....' TO mselect
DO CASE
CASE mselect = '1'
  CLOSE DATABASES
  CLEAR
  DO PhD10
CASE mselect = '2'
  CLOSE DATABASES
  CLEAR
  DO PhD20
CASE mselect = '3'
  CLOSE DATABASES
  CLEAR
  DO PhD30
CASE mselect = '4'
  CLOSE DATABASES
  CLEAR
  DO PhD40
CASE mselect = '5'
  CLOSE DATABASES
  CLEAR
  DO PhD50
CASE mselect = '6'
  CLOSE DATABASES
  CLEAR
  DO PhD60
CASE mselect = '*'
  CLOSE DATABASES
  CLEAR
  ERRORLEVEL(0)
  EXIT
ENDCASE

ENDDO
RETURN

*: EOF: PhD00.prg
```

```

*:*****:
*:
*:      Program: PhD10.prg
*:
*:      Title: Introduction
*:      Writer: Derrick Fielden
*:      Copyright (c) 1995, Derrick Fielden
*:
*:      Uses: SuperCalc 5 advanced spreadsheet modelling
*:            : dBASE III PLUS database/programming language
*:            : CLIPPER compiler
*:
*:*****:

```

```

CLEAR ALL
SET DATE BRITISH
SET COLOR TO W/R,W/R,,,W/R
SET TALK OFF
SET INTENSITY OFF
SET DELIMITER TO "[ ]"
SET DELIMITER ON
CLEAR
SET HEADING OFF
PUBLIC mquote
mquote = '"'
DO WHILE .T.
TEXT

```

Introduction

---

The Guernsey energy model enables parish based QQT demand 'clusters' to be met and matched by QQT supply sources.

Simulation takes into account the variability in the supply potential of alternative sources of energy using Monte-Carlo simulation techniques.

Nine of the Guernsey parishes are modelled, St.Peter and Torteval being combined into one entity for modelling purposes.

The QQT sources are selectable on the basis of energy, operational/maintenance and capital costs. An energy and financial analysis is provided to aid least-cost planning decisions.

Estimated electricity/heat tariffs are provided for each parish energy service company (ESCO).

\*. Return to Main Menu

```

ENDTEXT
ACCEPT 'Make your selection.....' TO mselect
DO CASE

```

```

CASE mselect = '*'
CLOSE DATABASES

```

```
CLEAR  
DO PhD00  
EXIT  
ENDCASE  
ENDDO  
RETURN  
*: EOF: PhD10.prg
```



```

*:*****:
*:
*:      Program: PhD20.prg
*:
*:      Title: Parish clusters
*:      Writer: Derrick Fielden
*:      Copyright (c) 1995, Derrick Fielden
*:
*:      Calls: EPMODEL1.cal
*:             : EPMODEL2.cal
*:             : EPMODEL3.cal
*:             : EPMODEL4.cal
*:             : EPMODEL5.cal
*:             : EPMODEL6.cal
*:             : EPMODEL7.cal
*:             : EPMODEL8.cal
*:             : EPMODEL9.cal
*:
*:      Uses: SuperCalc 5 advanced spreadsheet modelling
*:            : dBASE III PLUS database/programming language
*:            : CLIPPER compiler
*:
*:*****:

```

```

CLEAR ALL
SET DATE BRITISH
SET COLOR TO W/B,W/B,,W/B
SET TALK OFF
SET INTENSITY OFF
SET DELIMITER TO "[ ]"
SET DELIMITER ON
CLEAR

```

```

SET HEADING OFF
PUBLIC mquote
mquote = '"'
DO WHILE .T.
  CLEAR
  TEXT

```

**Parish clusters**

-----

1. Vale
2. St Sampsons
3. Castel
4. St.Saviour
5. St.Peter/Torteval
6. Forest
7. St.Andrew
8. St.Martin
9. St.Peter Port

\*. Return to Main Menu

```

ENDTEXT
@ 2,20 TO 21,55 DOUBLE
@ 23,0

```

```

ACCEPT 'Make your selection.....' TO mselect
DO CASE

CASE mselect = '1'
  CLOSE DATABASES
  CLEAR
  RUN C:\SC5\SC5 -s C:\SC5\EPMODEL\EPMODEL1.cal
CASE mselect = '2'
  CLOSE DATABASES
  CLEAR
  RUN C:\SC5\SC5 -s C:\SC5\EPMODEL\EPMODEL2.cal
CASE mselect = '3'
  CLOSE DATABASES
  CLEAR
  RUN C:\SC5\SC5 -s C:\SC5\EPMODEL\EPMODEL3.cal
CASE mselect = '4'
  CLOSE DATABASES
  CLEAR
  RUN C:\SC5\SC5 -s C:\SC5\EPMODEL\EPMODEL4.cal
CASE mselect = '5'
  CLOSE DATABASES
  CLEAR
  RUN C:\SC5\SC5 -s C:\SC5\EPMODEL\EPMODEL5.cal
CASE mselect = '6'
  CLOSE DATABASES
  CLEAR
  RUN C:\SC5\SC5 -s C:\SC5\EPMODEL\EPMODEL6.cal
CASE mselect = '7'
  CLOSE DATABASES
  CLEAR
  RUN C:\SC5\SC5 -s C:\SC5\EPMODEL\EPMODEL7.cal
CASE mselect = '8'
  CLOSE DATABASES
  CLEAR
  RUN C:\SC5\SC5 -s C:\SC5\EPMODEL\EPMODEL8.cal
CASE mselect = '9'
  CLOSE DATABASES
  CLEAR
  RUN C:\SC5\SC5 -s C:\SC5\EPMODEL\EPMODEL9.cal
CASE mselect = '*'
  CLOSE DATABASES
  CLEAR
  DO PhD00
  EXIT
ENDCASE
ENDDO
RETURN

*: EOF: PhD20.prg

```

```

*:*****:
*:
*:      Program: PhD30.prg
*:
*:      Title: Final parish models
*:      Writer: Derrick Fielden
*:      Copyright (c) 1995, Derrick Fielden
*:
*:      Calls: EP1T.cal
*:             : EP2T.cal
*:             : EP3T.cal
*:             : EP4T.cal
*:             : EP5T.cal
*:             : EP6T.cal
*:             : EP7T.cal
*:             : EP8T.cal
*:             : EP9T.cal
*:
*:      Uses: SuperCalc 5 advanced spreadsheet modelling
*:            : dBASE III PLUS database/programming language
*:            : CLIPPER compiler
*:
*:*****:

```

```

CLEAR ALL
SET DATE BRITISH
SET COLOR TO W/B,W/B,,,W/B
SET TALK OFF
SET INTENSITY OFF
SET DELIMITER TO "[ ]"
SET DELIMITER ON
CLEAR

```

```

SET HEADING OFF
PUBLIC mquote
mquote = '"'
DO WHILE .T.
  CLEAR
  TEXT

```

**Final parish models**  
-----

1. Vale
2. St Sampsons
3. Castel
4. St.Saviour
5. St.Peter/Torteval
6. Forest
7. St.Andrew
8. St.Martin
9. St.Peter Port

\*. Return to Main Menu

```

ENDTEXT
@ 2,20 TO 21,55 DOUBLE
@ 23,0

```

```

ACCEPT 'Make your selection.....' TO mselect
DO CASE

CASE mselect = '1'
  CLOSE DATABASES
  CLEAR
  RUN C:\SC5\SC5 -s C:\SC5\EPMODEL\EP1T.cal
CASE mselect = '2'
  CLOSE DATABASES
  CLEAR
  RUN C:\SC5\SC5 -s C:\SC5\EPMODEL\EP2T.cal
CASE mselect = '3'
  CLOSE DATABASES
  CLEAR
  RUN C:\SC5\SC5 -s C:\SC5\EPMODEL\EP3T.cal
CASE mselect = '4'
  CLOSE DATABASES
  CLEAR
  RUN C:\SC5\SC5 -s C:\SC5\EPMODEL\EP4T.cal
CASE mselect = '5'
  CLOSE DATABASES
  CLEAR
  RUN C:\SC5\SC5 -s C:\SC5\EPMODEL\EP5T.cal
CASE mselect = '6'
  CLOSE DATABASES
  CLEAR
  RUN C:\SC5\SC5 -s C:\SC5\EPMODEL\EP6T.cal
CASE mselect = '7'
  CLOSE DATABASES
  CLEAR
  RUN C:\SC5\SC5 -s C:\SC5\EPMODEL\EP7T.cal
CASE mselect = '8'
  CLOSE DATABASES
  CLEAR
  RUN C:\SC5\SC5 -s C:\SC5\EPMODEL\EP8T.cal
CASE mselect = '9'
  CLOSE DATABASES
  CLEAR
  RUN C:\SC5\SC5 -s C:\SC5\EPMODEL\EP9T.cal
CASE mselect = '*'
  CLOSE DATABASES
  CLEAR
  DO PhD00
  EXIT
  ENDCASE
ENDDO
RETURN

*: EOF: PhD30.prg

```

```

*:*****:
*:
*:      Program: Phd40.prg
*:
*:      Title: Energy and financial analysis
*:      Writer: Derrick Fielden
*:      Copyright (c) 1995, Derrick Fielden
*:
*:      Calls: EP1TA.Cal
*:             : EP2TA.Cal
*:             : EP3TA.Cal
*:             : EP4TA.Cal
*:             : EP5TA.Cal
*:             : EP6TA.Cal
*:             : EP7TA.Cal
*:             : EP8TA.Cal
*:             : EP9TA.Cal
*:
*:      Uses: SuperCalc 5 advanced spreadsheet modelling
*:            : dBASE III PLUS database/programming language
*:            : CLIPPER compiler
*:
*:*****:

```

```

CLEAR ALL
SET DATE BRITISH
SET COLOR TO W/B,W/B,,,W/B
SET TALK OFF
SET INTENSITY OFF
SET DELIMITER TO "[ ]"
SET DELIMITER ON
CLEAR

```

```

SET HEADING OFF
PUBLIC mquote
mquote = '"'
DO WHILE .T.
  CLEAR
  TEXT

```

### Energy and financial analysis

---

1. Vale
  2. St.Sampsons
  3. Castel
  4. St.Saviour
  5. St.Peter/Torteval
  6. Forest
  7. St.Andrew
  8. St.Martin
  9. St.Peter Port
- \*. Return to Main Menu

```

ENDTEXT
@ 2,20 TO 21,55 DOUBLE
@ 23,0

```

```

ACCEPT 'Make your selection.....' TO mselect
DO CASE

CASE mselect = '1'
  CLOSE DATABASES
  CLEAR
  RUN C:\SC5\SC5 -s C:\SC5\EPMODEL\EP1TA.cal
CASE mselect = '2'
  CLOSE DATABASES
  CLEAR
  RUN C:\SC5\SC5 -s C:\SC5\EPMODEL\EP2TA.cal
CASE mselect = '3'
  CLOSE DATABASES
  CLEAR
  RUN C:\SC5\SC5 -s C:\SC5\EPMODEL\EP3TA.cal
CASE mselect = '4'
  CLOSE DATABASES
  CLEAR
  RUN C:\SC5\SC5 -s C:\SC5\EPMODEL\EP4TA.cal
CASE mselect = '5'
  CLOSE DATABASES
  CLEAR
  RUN C:\SC5\SC5 -s C:\SC5\EPMODEL\EP5TA.cal
CASE mselect = '6'
  CLOSE DATABASES
  CLEAR
  RUN C:\SC5\SC5 -s C:\SC5\EPMODEL\EP6TA.cal
CASE mselect = '7'
  CLOSE DATABASES
  CLEAR
  RUN C:\SC5\SC5 -s C:\SC5\EPMODEL\EP7TA.cal
CASE mselect = '8'
  CLOSE DATABASES
  CLEAR
  RUN C:\SC5\SC5 -s C:\SC5\EPMODEL\EP8TA.cal
CASE mselect = '9'
  CLOSE DATABASES
  CLEAR
  RUN C:\SC5\SC5 -s C:\SC5\EPMODEL\EP9TA.cal
CASE mselect = '*'
  CLOSE DATABASES
  CLEAR
  DO PhD00
  EXIT
ENDCASE
ENDDO
RETURN

*: EOF: PhD40.prg

```

```

*:*****:
*:
*:      Program: Phd50.prg
*:
*:      Title: Simulation
*:      Writer: Derrick Fielden
*:      Copyright (c) 1995, Derrick Fielden
*:
*:      Calls: EP1TB.Cal
*:             : EP2TB.Cal
*:             : EP3TB.Cal
*:             : EP4TB.Cal
*:             : EP5TB.Cal
*:             : EP6TB.Cal
*:             : EP7TB.Cal
*:             : EP8TB.Cal
*:             : EP9TB.Cal
*:
*:      Uses: SuperCalc 5 advanced spreadsheet modelling
*:            : dBASE III PLUS database/programming language
*:            : CLIPPER compiler
*:*****:
CLEAR ALL
SET DATE BRITISH
SET COLOR TO W/B,W/B,,,W/B
SET TALK OFF
SET INTENSITY OFF
SET DELIMITER TO "[ ]"
SET DELIMITER ON
CLEAR

SET HEADING OFF
PUBLIC mquote
mquote = '"'
DO WHILE .T.
  CLEAR
  TEXT

                                Simulation
                                -----

                                1. Vale
                                2. St.Sampson
                                3. Castel
                                4. St.Saviour
                                5. St.Peter/Torteval
                                6. Forest
                                7. St.Andrew
                                8. St.Martin
                                9. St.Peter Port

                                *. Return to Main Menu

ENDTEXT
@ 2,20 TO 21,55 DOUBLE
@ 23,0
ACCEPT 'Make your selection.....' TO mselect

```

```

DO CASE

CASE mselect = '1'
  CLOSE DATABASES
  CLEAR
  RUN C:\SC5\SC5 -s C:\SC5\EPMODEL\EP1TB.cal
CASE mselect = '2'
  CLOSE DATABASES
  CLEAR
  RUN C:\SC5\SC5 -s C:\SC5\EPMODEL\EP2TB.cal
CASE mselect = '3'
  CLOSE DATABASES
  CLEAR
  RUN C:\SC5\SC5 -s C:\SC5\EPMODEL\EP3TB.cal
CASE mselect = '4'
  CLOSE DATABASES
  CLEAR
  RUN C:\SC5\SC5 -s C:\SC5\EPMODEL\EP4TB.cal
CASE mselect = '5'
  CLOSE DATABASES
  CLEAR
  RUN C:\SC5\SC5 -s C:\SC5\EPMODEL\EP5TB.cal
CASE mselect = '6'
  CLOSE DATABASES
  CLEAR
  RUN C:\SC5\SC5 -s C:\SC5\EPMODEL\EP6TB.cal
CASE mselect = '7'
  CLOSE DATABASES
  CLEAR
  RUN C:\SC5\SC5 -s C:\SC5\EPMODEL\EP7TB.cal
CASE mselect = '8'
  CLOSE DATABASES
  CLEAR
  RUN C:\SC5\SC5 -s C:\SC5\EPMODEL\EP8TB.cal
CASE mselect = '9'
  CLOSE DATABASES
  CLEAR
  RUN C:\SC5\SC5 -s C:\SC5\EPMODEL\EP9TB.cal
CASE mselect = '*'
  CLOSE DATABASES
  CLEAR
  DO PhD00
  EXIT
ENDCASE

ENDDO
RETURN

*: EOF: Phd50.prg

```



```

*:*****:
*:
*:      Program: PhD60.prg
*:
*:      Title: 30 year life-cycle ESCos
*:      Writer: Derrick Fielden
*:      Copyright (c) 1995, Derrick Fielden
*:
*:      Calls: EP1TC.Cal
*:             : EP2TC.Cal
*:             : EP3TC.Cal
*:             : EP4TC.Cal
*:             : EP5TC.Cal
*:             : EP6TC.Cal
*:             : EP7TC.Cal
*:             : EP8TC.Cal
*:             : EP9TC.Cal
*:
*:      Uses: SuperCalc 5 advanced spreadsheet modelling
*:            : dBASE III PLUS database/programming language
*:            : CLIPPER compiler
*:
*:*****:

```

```

CLEAR ALL
SET DATE BRITISH
SET COLOR TO W/B,W/B,,,W/B
SET TALK OFF
SET INTENSITY OFF
SET DELIMITER TO "[ ]"
SET DELIMITER ON
CLEAR

```

```

SET HEADING OFF
PUBLIC mquote
mquote = "'"
DO WHILE .T.
  CLEAR
  TEXT

```

### 30 year life-cycle ESCos

---

1. Vale
2. St.Sampsons
3. Castel
4. St.Saviour
5. St.Peter/Torteval
6. Forest
7. St.Andrew
8. St.Martin
9. St.Peter Port

\*. Return to Main Menu

```

ENDTEXT
@ 2,20 TO 21,55 DOUBLE
@ 23,0

```

```

ACCEPT 'Make your selection.....' TO mselect
DO CASE

CASE mselect = '1'
  CLOSE DATABASES
  CLEAR
  RUN C:\SC5\SC5 -s C:\SC5\EPMODEL\EP1TC.cal
CASE mselect = '2'
  CLOSE DATABASES
  CLEAR
  RUN C:\SC5\SC5 -s C:\SC5\EPMODEL\EP2TC.cal
CASE mselect = '3'
  CLOSE DATABASES
  CLEAR
  RUN C:\SC5\SC5 -s C:\SC5\EPMODEL\EP3TC.cal
CASE mselect = '4'
  CLOSE DATABASES
  CLEAR
  RUN C:\SC5\SC5 -s C:\SC5\EPMODEL\EP4TC.cal
CASE mselect = '5'
  CLOSE DATABASES
  CLEAR
  RUN C:\SC5\SC5 -s C:\SC5\EPMODEL\EP5TC.cal
CASE mselect = '6'
  CLOSE DATABASES
  CLEAR
  RUN C:\SC5\SC5 -s C:\SC5\EPMODEL\EP6TC.cal
CASE mselect = '7'
  CLOSE DATABASES
  CLEAR
  RUN C:\SC5\SC5 -s C:\SC5\EPMODEL\EP7TC.cal
CASE mselect = '8'
  CLOSE DATABASES
  CLEAR
  RUN C:\SC5\SC5 -s C:\SC5\EPMODEL\EP8TC.cal
CASE mselect = '9'
  CLOSE DATABASES
  CLEAR
  RUN C:\SC5\SC5 -s C:\SC5\EPMODEL\EP9TC.cal

CASE mselect = '*'
  CLOSE DATABASES
  CLEAR
  DO PhD00
  EXIT
ENDCASE

ENDDO
RETURN

*: EOF: Phd60.prg

```

**APPENDIX F**

Typical diurnal and seasonal electricity profiles  
for hotels and vineries

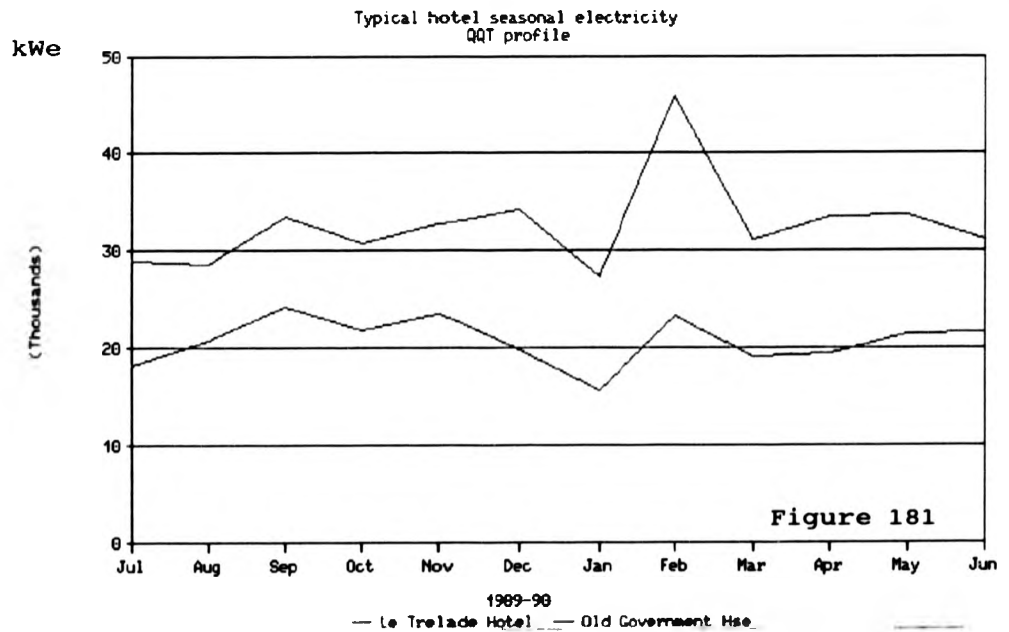
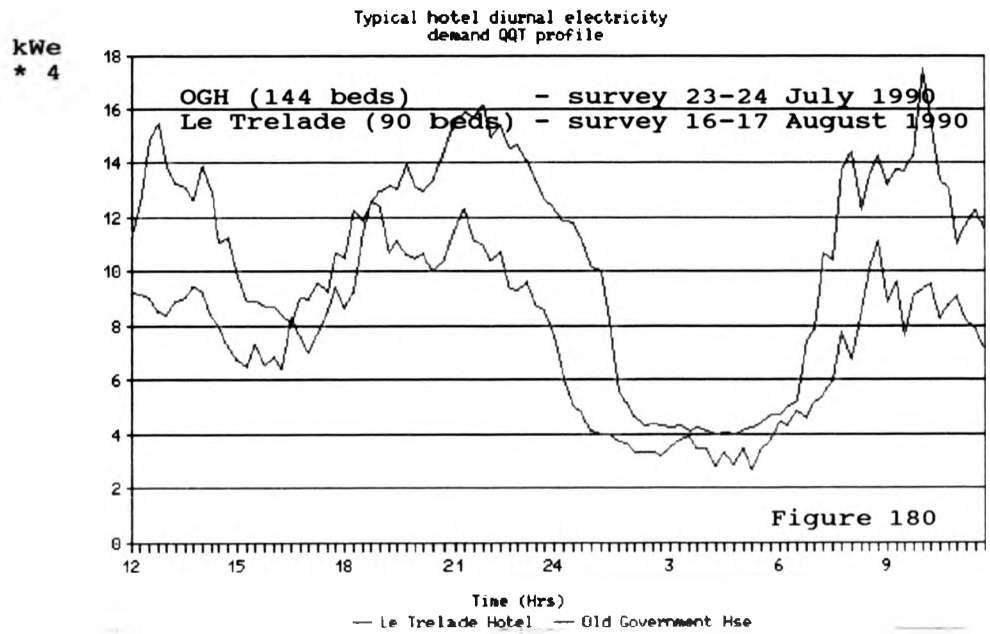

kWe  
\* 4

Typical vinery diurnal electricity demand QQT profile

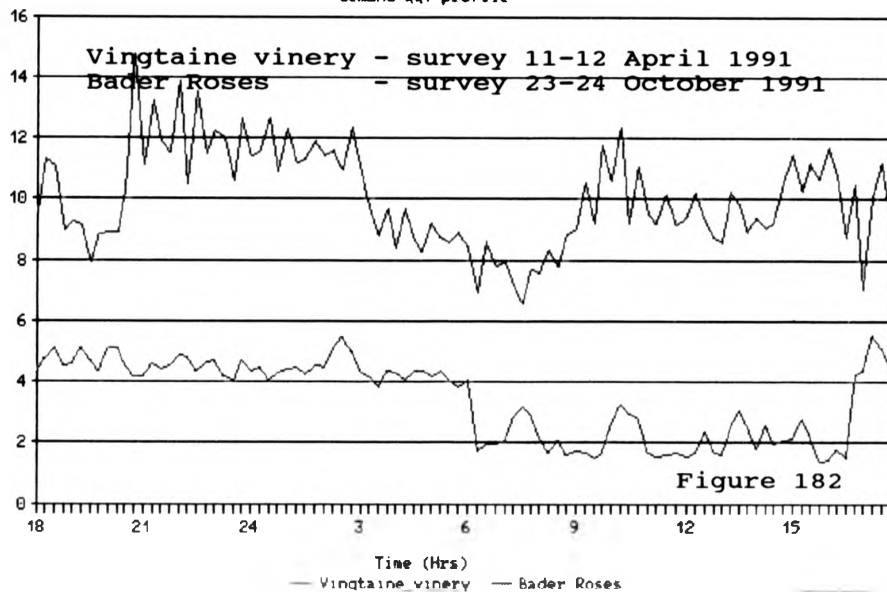

kWe

Typical vinery seasonal electricity demand QQT profile

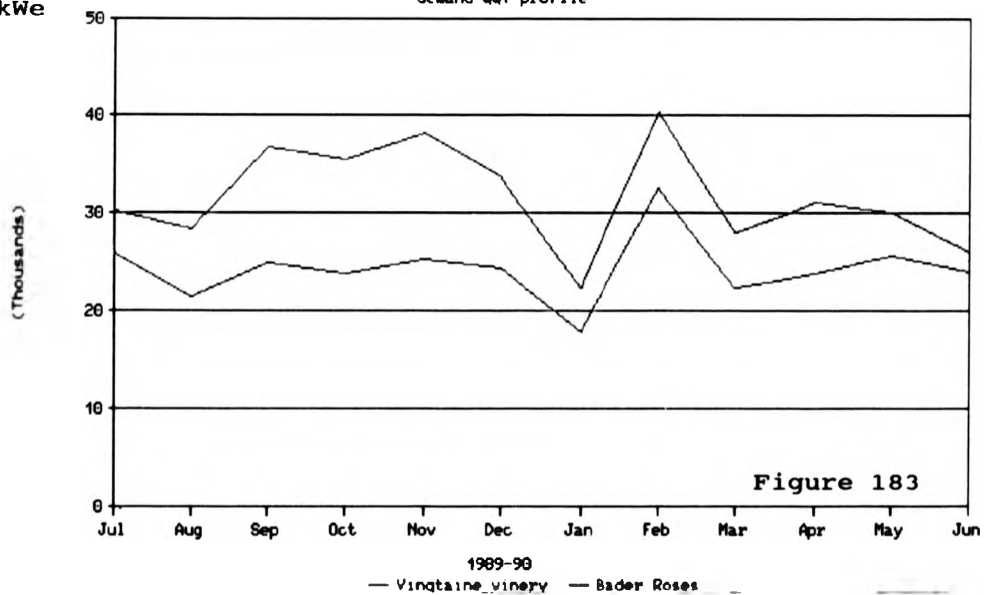

**APPENDIX G**

**Diurnal electricity demand profiles for unrestricted domestic (winter weekday) annual consumption ranges (42 F)**

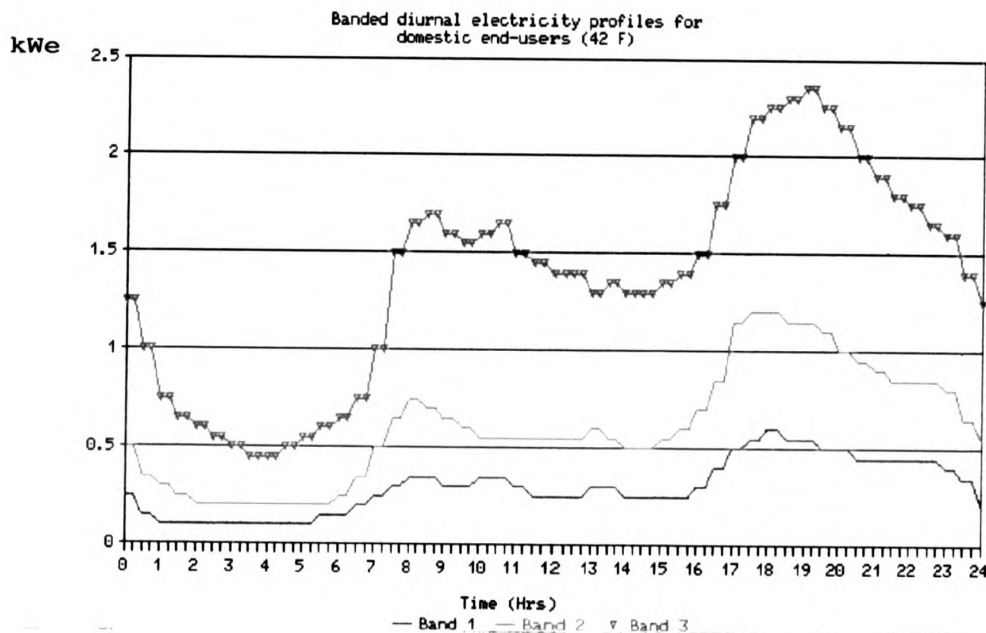

**Figure 184**

(By kind permission of the U.K. Electricity Association)

**Average domestic electricity consumption ranges:-**

**Band 1 - up to 400 kWhe**

**Band 2 - 401-8000 kWhe**

**Band 3 - 8001-80000 kWhe**

**APPENDIX H**



**Capital cost of cogeneration (diesel based) plant (1992,  
not including waste and supplementary heat boilers)**

Unit size:	48 kWe	70 kWe	110 kWe	150 kWe	220 kWe
Cap/in. (£)	36410	43949	65500	81215	105340

Unit size:	200 kWe	255 kWe	385 kWe	500 kWe	750 kWe
Cap/in. (£)	126000	148000	196100	247900	311800

Unit size:	950 kWe	1.9 MWe	2.835 MWe	3.3 MWe	4.4 MWe
Cap/in. (£)	235000	460000	560000	960000	1150000

Unit size:	3.1 MWe	4.2 MWe	4.7 MWe	6.2 MWe	14 MWe
Cap/in. (£)	990000	1200000	1310000	1.8*10 <sup>6</sup>	16*10 <sup>6</sup>

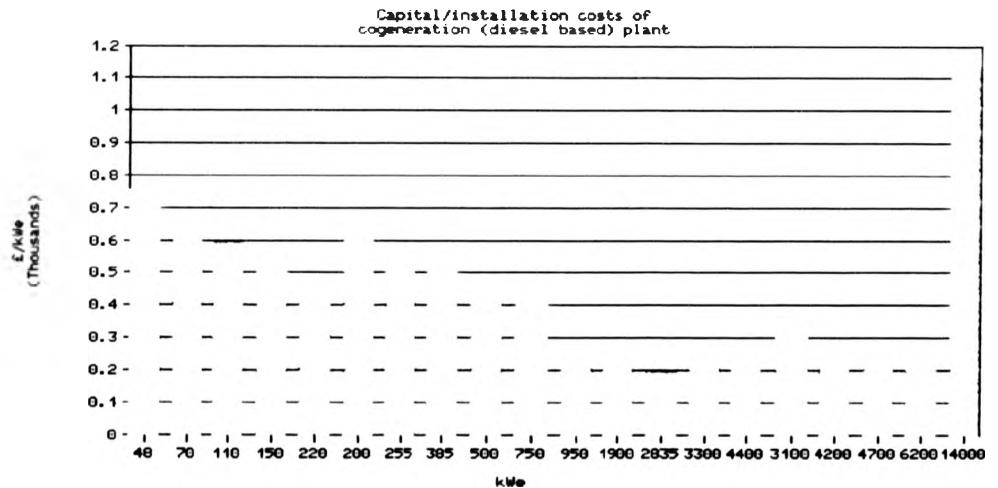

Capital/installation cost per kWe<sup>1</sup>

Figure 185

1. First two - Ford Powertorque (medium speed)
- Next three - Perkins (medium speed)
- Next five - Caterpillar (medium speed)
- Next nine - Wirlces (medium speed)
- Last - Sulzer (slow speed)

**APPENDIX I**

**QOT data for the Forest abstraction sites**

**(1) States Airport site**

Annual consumption of electrical energy is 1,706 MWe, at a 1992 cost of £135,340. Annual primary energy imports for space/water heating 99,215 litres, at a 1992 cost of £14,783.

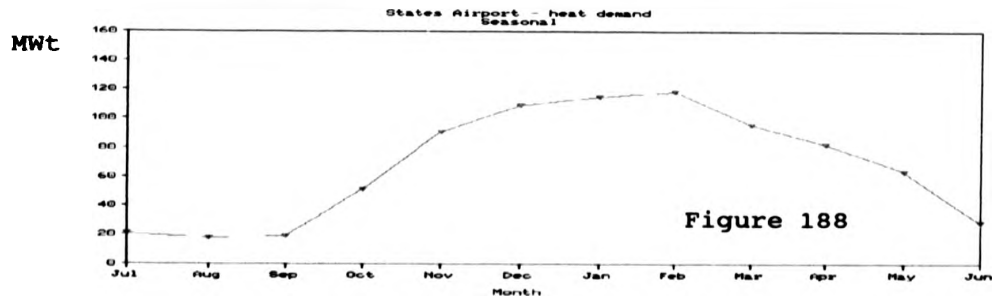
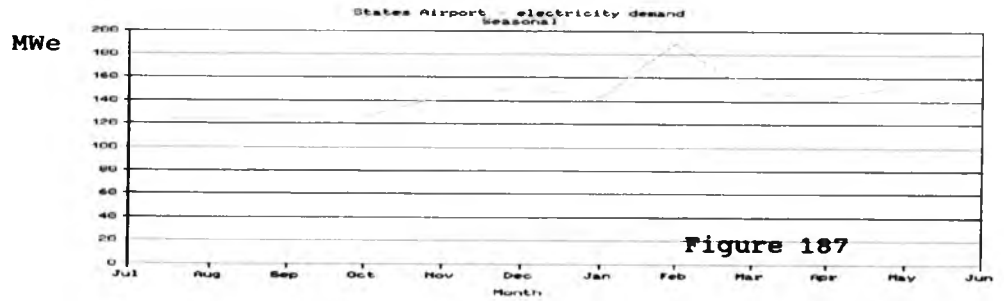
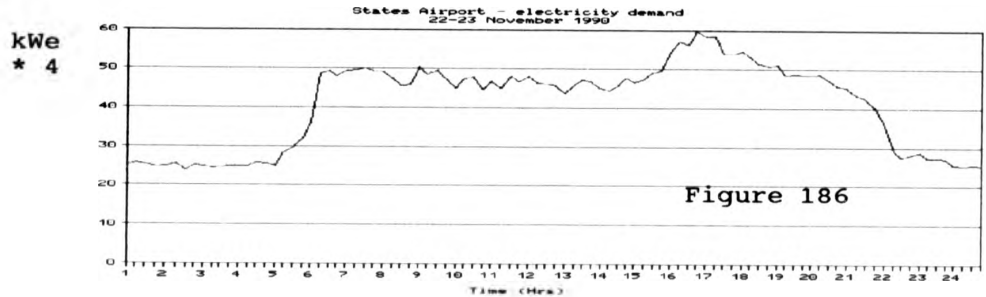

(2) Sovereign Flower's site

Annual consumption of electrical energy is 689 MWe, at a 1992 cost of £38,714. Annual primary energy imports for space/water heating 367,000 litres, at a 1992 cost of £40,370.

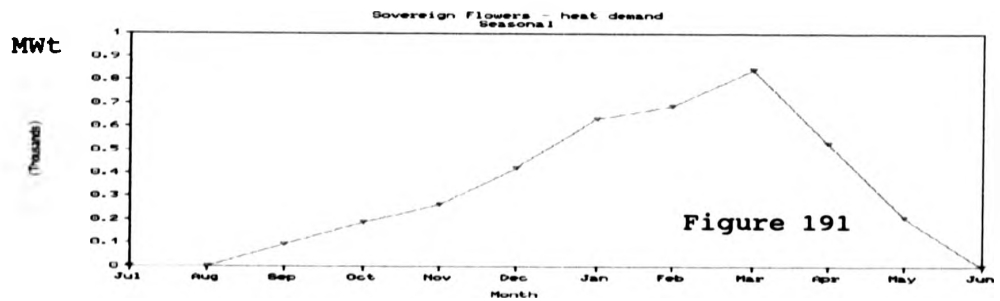
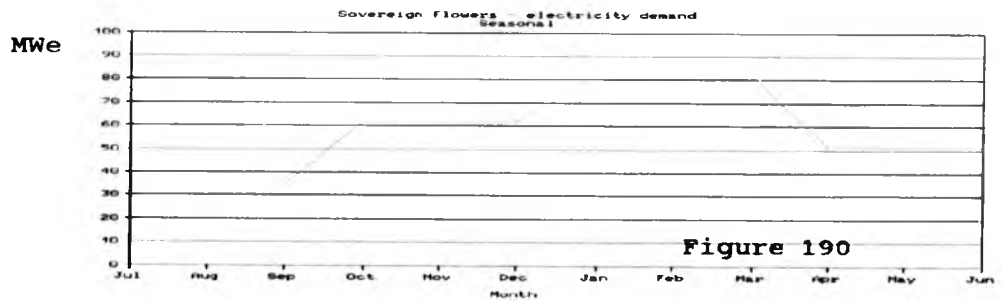
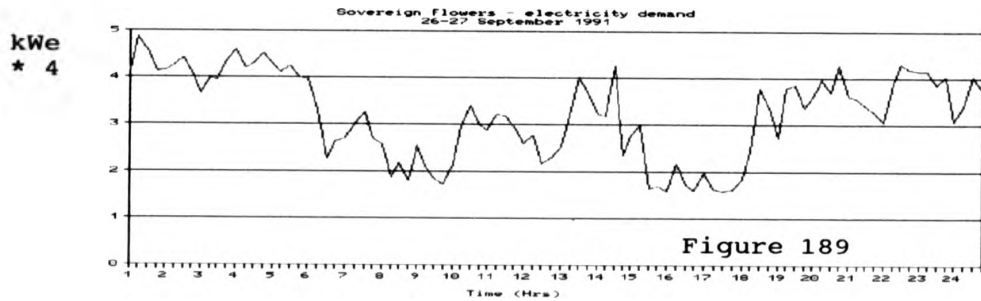

**(3) Mallard Country Club site**

Annual consumption of electrical energy is 210 MWe, at a 1992 cost of £18,217. Annual primary energy imports for space/water heating 37,500 litres, at a 1992 cost of £5,588.

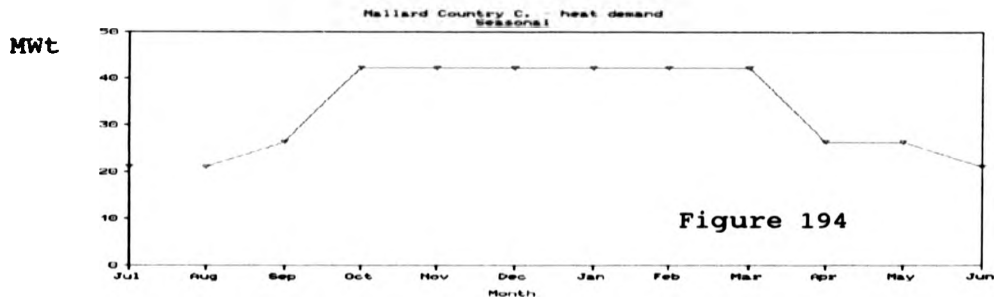
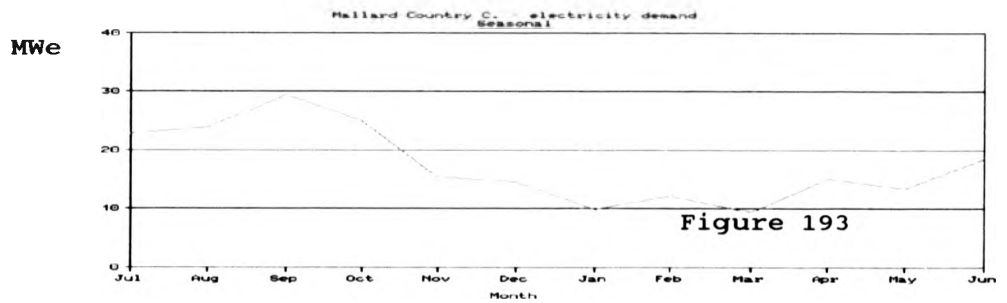
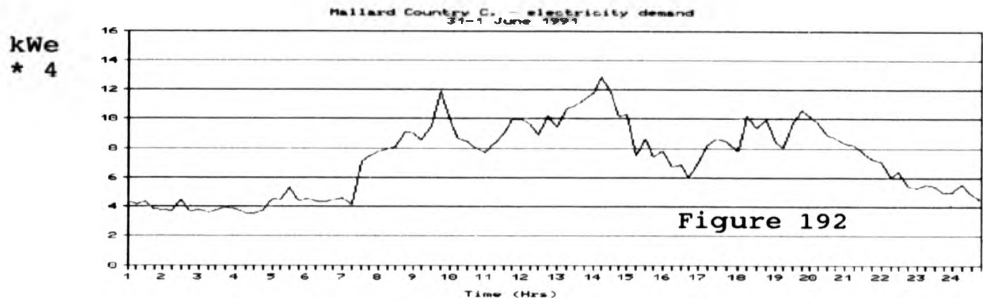

**APPENDIX J**

### Diversified demand (or coincident demand)

Is the demand of a composite group (as a whole) of somewhat unrelated energy loads over a specified time period.

#### Diversity Factor (DF):

Is "the ratio of the sum of the individual maximum demands of the various energy end-user sites to the maximum demand of the group".

Diversity Factor<sup>1</sup> is thus:-

$$DF = \frac{\text{Sum of individual maximum demands}}{\text{Coincident maximum demands}}$$

or

$$DF = \frac{D1 + D2 + D3 + \dots + Dn}{Dg}$$

Where  $D_i$  = Maximum demand of load  $i$ , disregarding time of occurrence.

$D_g = D1 + D2 + D3 + \dots + Dn$  = Coincident maximum demand of group  $n$  loads.

#### Coincidence Factor (CF):

Is "the ratio of the maximum coincident total demand of a group of energy end-users to the sum of the maximum demands of individual end-users comprising the group".

The Coincidence Factor is thus the reciprocal of Diversity Factor,

$$CF = \frac{1}{DF}$$

1. The Diversity Factor can be equal to or greater than 1.0.

**APPENDIX K**



## Final parish diurnal electricity profiles

### Vale ESCo<sup>1</sup>

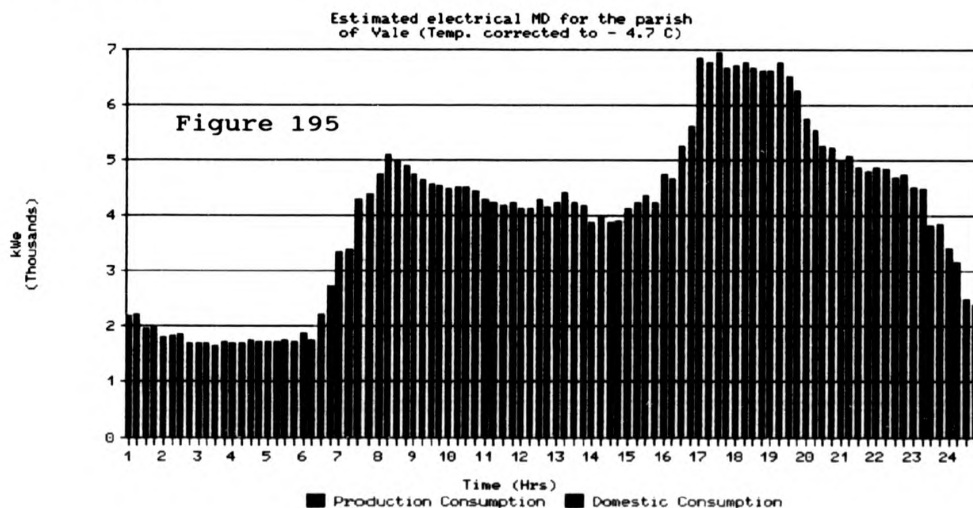

### St. Sampson's ESCo<sup>2</sup>

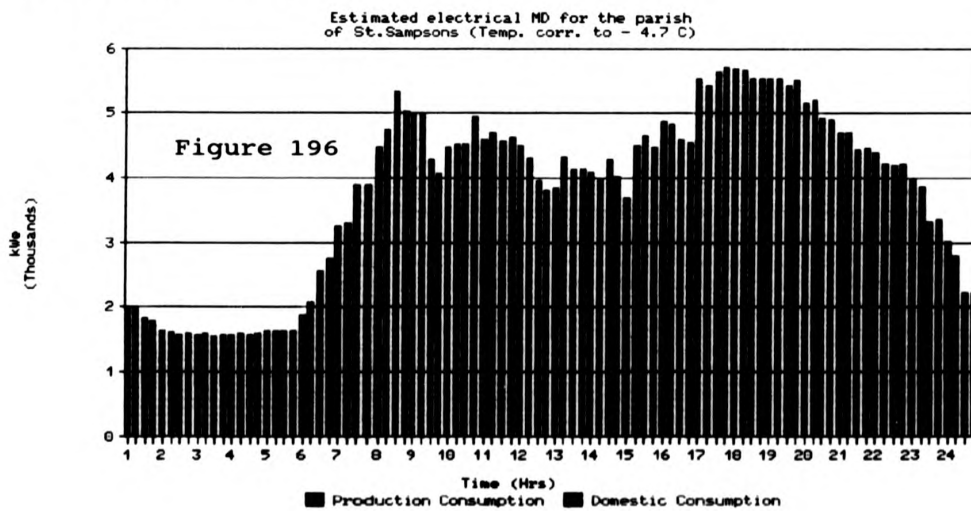

1. Cogeneration proposal - 2 \* 2.835 MWe & 1 \* 4.2 MWe

2. Cogeneration proposal - 1 \* 4.2 MWe, 1 \* 2.835 MWe & 1 \* 1.9 MWe

### Castel ESCo<sup>1</sup>

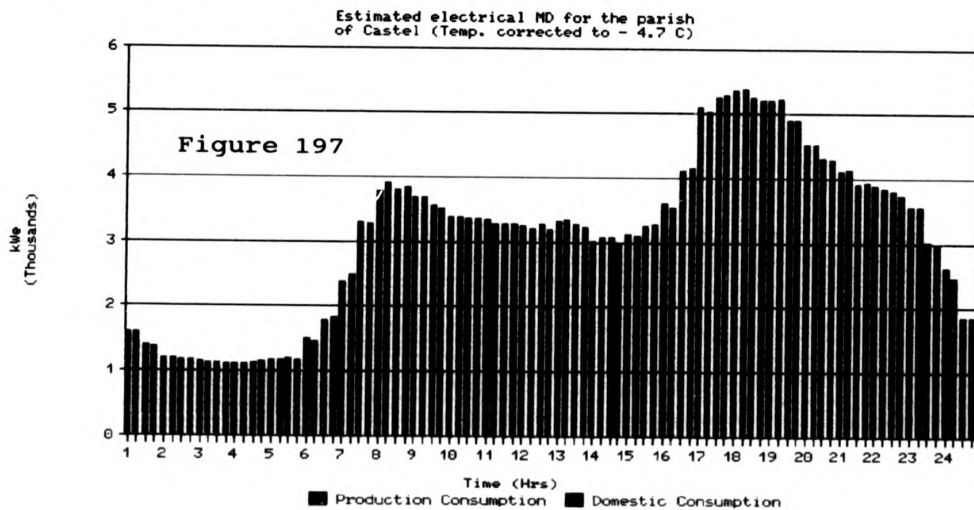

### St.Saviour's ESCo<sup>2</sup>

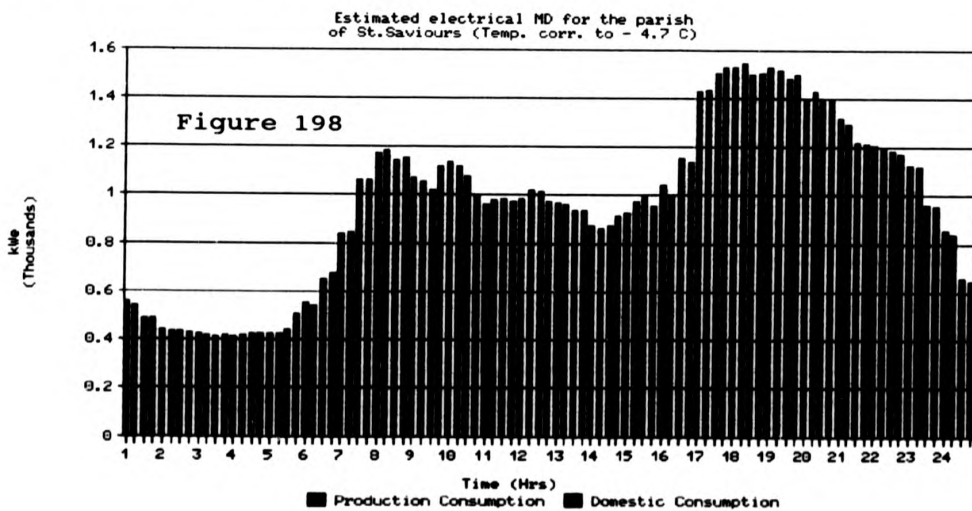

1. Cogeneration proposal - 2 \* 1.9 MWe & 1 \* 3.3 MWe

2. Cogeneration proposal - 2 \* 500 kWe & 1 \* 950 kWe

### St. Peter/Torteval ESCo<sup>1</sup>

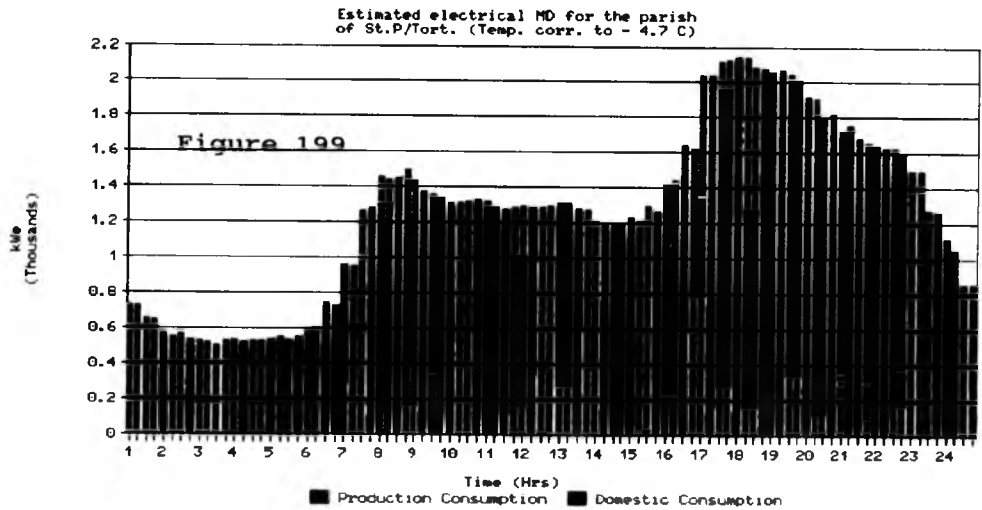

### St. Andrew's ESCo<sup>2</sup>

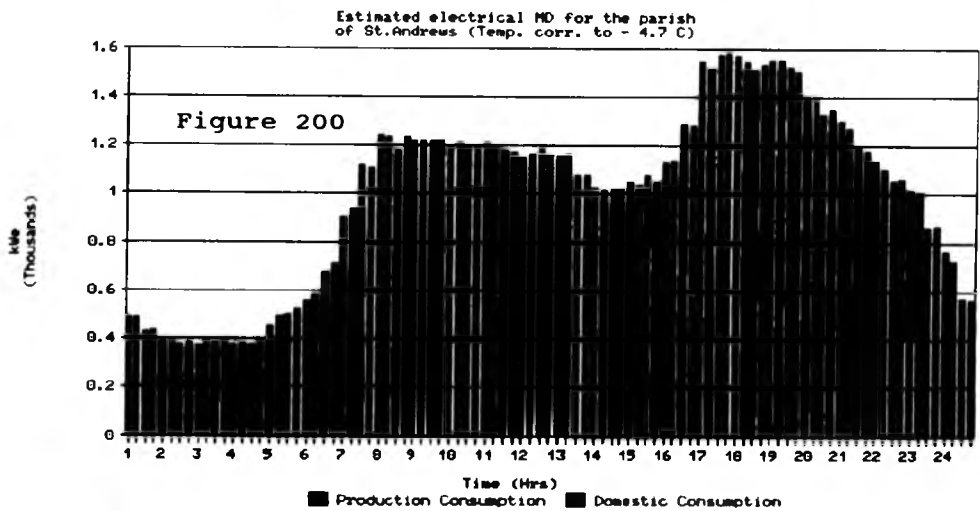

1. Cogeneration proposal - 1 \* 750 kWe, 1 \* 1.9 MWe & 1 \* 950 kWe

2. Cogeneration proposal - 2 \* 500 kWe & 1 \* 950 kWe

### St.Martin's ESCo<sup>1</sup>

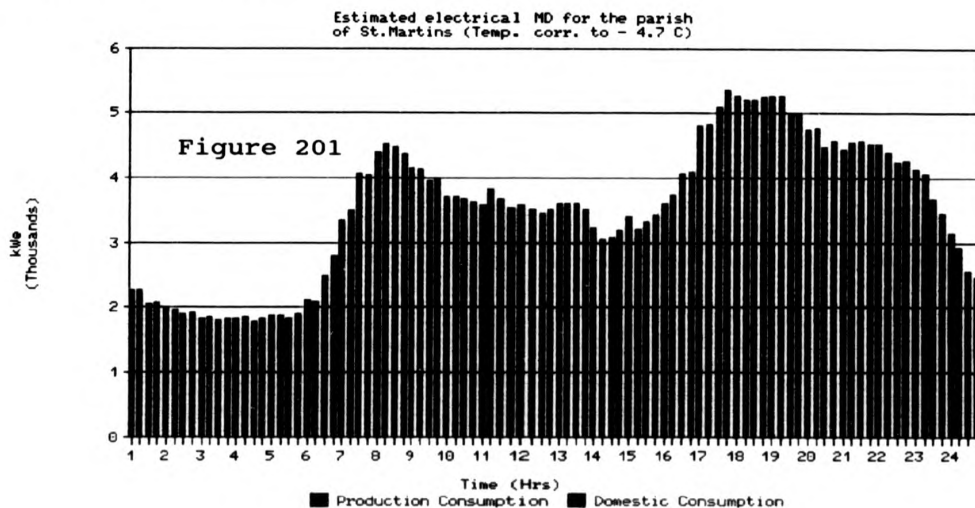

### St.Peter Port ESCo<sup>2</sup>

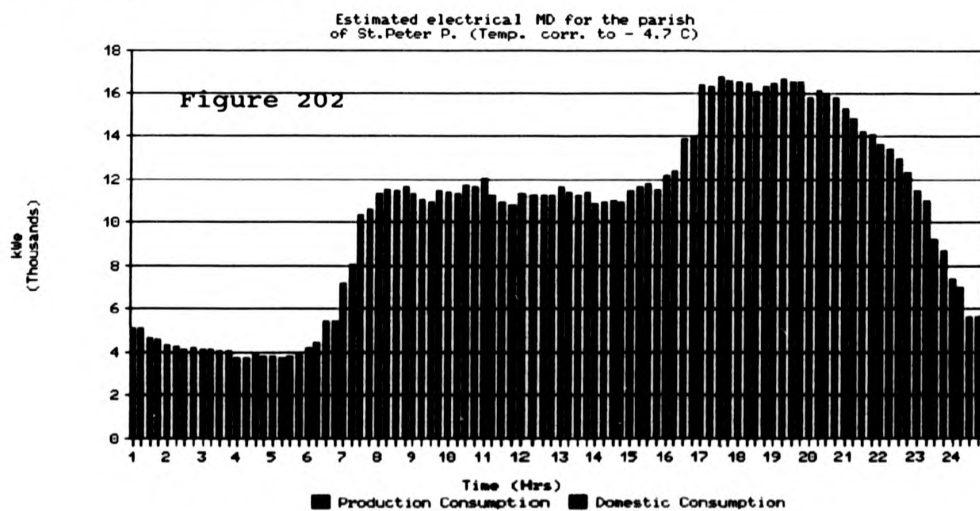

1. Cogeneration proposal - 1 \* 3.3 MWe, 1 \* 2.835 MWe & 1 \* 950 kWe

2. Cogeneration proposal - 2 \* 4.7 MWe & 2 \* 6.2 MWe

**APPENDIX L**

VALE SEASONAL HEAT

	Alliance M/h	* 25.8	Vingtaine M/h	* 13.82	Novotel M/h	* 2.71	Juas M/h	* 1.33	Dom avg M/h	100% Dom M/h	Total non-Dom M/h	80% Eff non-Dom M/h	Corr non-Dom M/h	Total ESCO M/h
Jul	0	0	191	2637	32	86	0	0	636	2166	2723	2178	1667	3834
Aug	0	0	95	1318	24	66	0	0	636	2166	1384	1107	848	3014
Sep	0	0	286	3955	19	51	0	0	636	2166	4007	3205	2454	4620
Oct	0	0	286	3955	46	125	0	0	1908	6499	4081	3264	2499	8998
Nov	0	0	382	5274	43	117	0	0	1908	6499	5391	4313	3301	9800
Dec	0	0	424	5860	36	97	0	0	1908	6499	5957	4766	3648	10147
Jan	0	0	382	5274	63	170	0	0	1908	6499	5444	4355	3334	9832
Feb	0	0	445	6153	60	163	0	0	1908	6499	6315	5052	3867	10366
Mar	0	0	445	6153	51	138	0	0	1908	6499	6291	5033	3853	10351
Apr	0	0	286	3955	54	146	0	0	636	2166	4101	3281	2511	4678
May	0	0	286	3955	54	145	0	0	636	2166	4101	3281	2511	4678
Jun	0	0	191	2637	26	70	0	0	636	2166	2706	2165	1657	3824
										51989		42001	32151	84141

ESCO Monthly heat averages  
(Vale)

Heat from CHP

	Alliance M/h	* 25.8	Vingtaine M/h	* 13.82	Novotel M/h	* 2.71	Juas M/h	* 1.33	Dom avg M/h	100% Dom M/h	Total non-Dom M/h	80% Eff non-Dom M/h	Corr non-Dom M/h	Total ESCO M/h
Jul	63	1632	26	358	48	129	86	115	254	865	3099	4379	3099	3834
Aug	63	1634	22	298	44	119	88	116	254	865	3032	4284	3032	3834
Sep	71	1822	25	345	61	166	101	134	254	865	3333	4709	3333	4620
Oct	64	1652	24	330	62	167	100	133	254	865	3147	4447	3147	4620
Nov	60	1557	25	351	41	111	109	146	509	1734	3898	5508	3898	8998
Dec	60	1556	24	338	43	118	108	143	509	1734	3888	5494	3888	9800
Jan	43	1119	18	247	46	123	101	135	509	1734	3358	4745	3358	10147
Feb	74	1921	33	452	56	152	126	167	509	1734	4425	6253	4425	10366
Mar	53	1371	22	311	51	137	98	131	509	1734	3683	5205	3683	10351
Apr	57	1472	24	331	49	132	61	82	509	1734	3750	5299	3750	4678
May	58	1503	26	357	82	223	67	89	254	865	3037	4291	3037	3824
Jun	61	1562	24	332	64	172	107	143	254	865	3074	4343	3074	3824
											41725	58957	41725	84141

VALE SEASONAL POWER

	Alliance M/h	* 25.8	Vingtaine M/h	* 13.82	Novotel M/h	* 2.71	Juas M/h	* 1.33	Dom avg M/h	100% Dom M/h	Total non-Dom M/h	80% Eff non-Dom M/h	Corr non-Dom M/h	Total ESCO M/h
Jul	63	1632	26	358	48	129	86	115	254	865	3099	4379	3099	3834
Aug	63	1634	22	298	44	119	88	116	254	865	3032	4284	3032	3834
Sep	71	1822	25	345	61	166	101	134	254	865	3333	4709	3333	4620
Oct	64	1652	24	330	62	167	100	133	254	865	3147	4447	3147	4620
Nov	60	1557	25	351	41	111	109	146	509	1734	3898	5508	3898	8998
Dec	60	1556	24	338	43	118	108	143	509	1734	3888	5494	3888	9800
Jan	43	1119	18	247	46	123	101	135	509	1734	3358	4745	3358	10147
Feb	74	1921	33	452	56	152	126	167	509	1734	4425	6253	4425	10366
Mar	53	1371	22	311	51	137	98	131	509	1734	3683	5205	3683	10351
Apr	57	1472	24	331	49	132	61	82	509	1734	3750	5299	3750	4678
May	58	1503	26	357	82	223	67	89	254	865	3037	4291	3037	3824
Jun	61	1562	24	332	64	172	107	143	254	865	3074	4343	3074	3824
											41725	58957	41725	84141

VALE SUPPLEMENTARY HEAT REQUIREMENT

	Corr	Total
Jul	-2711	ESCo
Aug	-3437	-545
Sep	-2255	-1271
Oct	-1948	-89
Nov	-2206	4550
Dec	-1846	4292
Jan	-1411	5088
Feb	-2386	4113
Mar	-1352	5147
Apr	-2787	-621
May	-1780	387
Jun	-2686	-520
	0	28229

ESCO monthly heat averages  
(St. Sampsons)

ST. SAMPSONS SEASONAL HEAT												
	Prison	* 27.9	Kenilworth	* 6.9	Vardes @	* 2.9	Dom avg	0%	Total	80% Eff	Corr	Total
	M/h	M/h	M/h	M/h	M/h	M/h	M/h	Dom	non-Dom	M/h	M/h	ESCO
								M/h	M/h	M/h	M/h	M/h
Jul	90	2514	126	870	0	0	636	0	3384	2707	2072	2072
Aug	0	0	862	5946	0	0	636	0	5946	4757	3642	3642
Sep	95	2662	723	4988	0	0	636	0	7650	6120	4685	4685
Oct	191	5323	267	1843	0	0	1908	0	7166	5733	4389	4389
Nov	193	5379	763	5266	0	0	1908	0	10645	8516	6519	6519
Dec	148	4140	2438	16822	0	0	1908	0	20963	16770	12837	12837
Jan	180	5028	2841	19602	0	0	1908	0	24629	19703	15083	15083
Feb	180	5028	2300	15871	0	0	1908	0	20999	16719	12799	12799
Mar	180	5028	2109	14555	0	0	1908	0	19582	15666	11992	11992
Apr	180	5028	2099	14482	0	0	636	0	19509	15607	11947	11947
May	180	5028	1116	7702	0	0	636	0	12729	10183	7795	7795
Jun	90	2514	631	4352	0	0	636	0	6866	5492	4205	4205
									127975	97965	97965	97965

ST. SAMPSONS SEASONAL POWER

ST. SAMPSONS SEASONAL POWER											
	Prison	* 27.9	Kenilworth	* 6.9	Vardes @	* 2.9	Dom avg	0%	Total	Heat from CHP	Total
	M/h	M/h	M/h	M/h	M/h	M/h	M/h	Dom	non-Dom	M/h	M/h
								M/h	M/h	M/h	M/h
Jul	4	99	34	231	106	306	251	753	1390	1964	1964
Aug	8	218	28	195	102	297	251	753	1462	2066	2066
Sep	11	319	30	208	67	194	251	753	1474	2082	2082
Oct	11	319	30	209	86	249	251	753	1529	2161	2161
Nov	13	356	14	96	112	324	502	1505	2281	3224	3224
Dec	12	329	17	118	115	334	502	1505	2286	3231	3231
Jan	31	874	25	172	96	279	502	1505	2831	4001	4001
Feb	92	2555	45	311	97	280	502	1505	4652	6573	6573
Mar	18	512	34	237	104	301	502	1505	2556	3612	3612
Apr	43	1195	37	258	103	299	502	1505	3258	4603	4603
May	42	1165	39	267	104	303	251	753	2487	3515	3515
Jun	36	1013	33	229	94	272	251	753	2267	3204	3204
									22675	40235	40235

ST. SAMPSONS SUPPLEMENTARY HEAT REQUIREMENT

	Corr	Total
Jul	109	109
Aug	1575	1575
Sep	2603	2603
Oct	2228	2228
Nov	3296	3296
Dec	9607	9607
Jan	11082	11082
Feb	6225	6225
Mar	8380	8380
Apr	7344	7344
May	4281	4281
Jun	1001	1001
	57730	57730

ESCO monthly heat averages  
(Castel)

CASTEL SEASONAL HEAT												
	King Edu VII Mkht	* 6	Hougue du P Mkht	* 10	States Water Mkht	* 1.6	Dom avg Mkht	31% Dom Mkht	Total non-Dom Mkht	80% Eff Mkht	Corr Mkht	Total ESCO Mkht
Jul	482	2894	32	317	0	0	636	601	3211	2569	1967	2567
Aug	361	2169	24	242	0	0	636	601	2411	1929	1476	2077
Sep	382	2290	19	190	0	0	636	601	2479	1984	1518	2119
Oct	478	2868	46	462	0	0	1908	1802	3331	2664	2040	3841
Nov	572	3434	43	432	0	0	1908	1802	3867	3094	2368	4170
Dec	693	4159	36	359	0	0	1908	1802	4519	3615	2767	4569
Jan	649	3892	63	628	0	0	1908	1802	4520	3616	2768	4570
Feb	787	4719	60	600	0	0	1908	1802	5319	4255	3257	5059
Mar	587	3523	51	511	0	0	1908	1802	4034	3227	2471	4272
Apr	590	3543	54	539	0	0	636	601	4081	3265	2499	3100
May	481	2887	54	537	0	0	636	601	3424	2739	2097	2698
Jun	493	2957	26	257	0	0	636	601	3214	2571	1968	2569
								14413		35528	27197	41610

CASTEL SEASONAL POWER

CASTEL SUPPLEMENTARY HEAT REQUIREMENT												
	King Edu VII Mkht	* 6	Hougue du P Mkht	* 10	States Water Mkht	* 1.6	Dom avg Mkht	31% Dom Mkht	Total non-Dom Mkht	80% Eff Mkht	Corr Mkht	Total ESCO Mkht
Jul	57	342	13	130	39	63	268	816	1351	1909		
Aug	54	322	13	130	35	56	268	816	1324	1871		
Sep	61	368	13	130	33	53	268	816	1367	1932		
Oct	59	354	13	129	21	34	268	816	1333	1883		
Nov	65	391	13	129	23	37	536	1633	2189	3093		
Dec	64	387	13	129	27	43	536	1633	2191	3096		
Jan	47	283	11	115	32	51	536	1633	2081	2941		
Feb	84	502	11	115	41	66	536	1633	2315	3271		
Mar	58	347	11	115	42	68	536	1633	2162	3054		
Apr	61	363	13	129	41	66	536	1633	2190	3095		
May	61	363	13	129	66	106	268	816	1415	1999		
Jun	58	348	13	129	47	76	268	816	1369	1935		
									21288	30080		

CASTEL SUPPLEMENTARY HEAT REQUIREMENT

	Corr	Total
Jul	57	658
Aug	-395	205
Sep	-413	187
Oct	156	1958
Nov	-725	1076
Dec	-329	1472
Jan	-173	1629
Feb	-14	1788
Mar	-584	1218
Apr	-595	5
May	98	696
Jun	34	634
	345	11530



ST. SAVIOURS SEASONAL HEAT

Mont	Mont Variouf	Les Mourant	Atlantique	Reservoir	Dom avg	59% Dom	Total non-Dom	80% Eff	Corr	Total ESCo
	Mhht * 11.2	Mhht * 6.1	Mhht * 1.9	Mhht	Mhht	Mhht	Mhht	Mhht	Mhht	Mhht
Jul	24	270	32	0	636	322	1106	885	677	999
Aug	24	270	24	0	636	322	1092	873	669	991
Sep	24	270	19	0	636	322	1082	865	663	984
Oct	24	270	19	0	1908	966	1522	1217	932	1898
Nov	24	270	19	0	1908	966	1516	1213	928	1894
Dec	48	540	36	0	1908	966	2160	1728	1323	2289
Jan	48	540	254	0	1908	966	2211	1769	1354	2320
Feb	72	810	191	0	1908	966	2087	1670	1278	2244
Mar	48	540	318	0	1908	966	2577	2061	1578	2544
Apr	48	540	254	0	636	322	2194	1755	1344	1666
May	48	540	191	0	636	322	1806	1444	1106	1428
Jun	24	270	64	0	636	322	707	565	433	755
						7727		16046	12283	20010

ST. SAVIOURS SEASONAL POWER

Mont	Mont Variouf	Les Mourant	Atlantique	Reservoir	Dom avg	59% Dom	Total non-Dom	80% Eff	Corr	Total ESCo
	Mhhe * 11.2	Mhhe * 6.1	Mhhe * 1.9	Mhhe	Mhhe	Mhhe	Mhhe	Mhhe	Mhhe	Mhhe
Jul	4	45	7	37	295	253	475	671	481	556
Aug	4	45	7	37	295	253	481	679	470	556
Sep	4	45	7	37	295	253	470	663	470	556
Oct	7	79	9	37	295	253	502	709	502	556
Nov	7	79	9	37	590	506	751	1061	751	556
Dec	7	79	9	37	590	506	750	1059	747	556
Jan	9	103	9	37	590	506	747	1056	790	556
Feb	9	103	9	37	590	506	766	1083	766	556
Mar	9	103	9	37	590	506	806	1138	777	556
Apr	9	106	9	39	295	253	550	777	550	556
May	9	106	9	39	295	253	532	752	532	556
Jun	9	106	9	39	295	253	7619	10765	7619	556

ST. SAVIOURS SUPPLEMENTARY HEAT REQUIREMENT

Month	Corr	Total non-Dom	Total ESCo
Jul	6	328	334
Aug	-11	311	300
Sep	-1	321	320
Oct	223	1188	1411
Nov	-133	833	700
Dec	263	1229	1492
Jan	298	1264	1562
Feb	163	1128	1291
Mar	495	1461	1956
Apr	205	527	732
May	329	651	980
Jun	-319	2	-317
1982		9245	9245

ESCo monthly heat averages (St. Saviours)

Heat from CHP  
<H/P = 1.413>

ESCO monthly heat averages  
(St. Peter/Torteval)

ST. P./TORTEVAL SEASONAL HEAT

	Le Riche MMht	* 5.68	Bader Roses MMht	* 2.82	Imperial MMht	* 6.39	Dom avg MMht	48% Dom	Total non-Dom	80% Eff MMht	Corr MMht	Total ESCO MMht
Jul	0	0	329	928	32	203	636	340	1130	904	692	1032
Aug	0	0	224	632	24	155	636	340	787	629	482	822
Sep	0	0	493	1391	19	121	636	340	1512	1210	926	1266
Oct	0	0	1421	4006	46	295	1908	1019	4301	3441	2634	3653
Nov	0	0	1794	5060	43	276	1908	1019	5336	4269	3268	4287
Dec	0	0	2094	5904	36	230	1908	1019	6134	4907	3756	4776
Jan	0	0	2393	6748	63	401	1908	1019	7149	5719	4378	5397
Feb	0	0	2243	6326	51	363	1908	1019	7131	5705	4367	5386
Mar	0	0	1795	5061	54	344	1908	1019	6652	5322	4074	5093
Apr	0	0	972	2741	54	343	636	340	5405	4324	3310	3650
May	0	0	596	1687	26	164	636	340	3084	2467	1869	2228
Jun	0	0	0	0	0	0	636	340	1851	1481	1134	1473
								8155	40378	30909		39064

ST. P./TORTEVAL SEASONAL POWER

	Le Riche MMhe	* 5.68	Bader Roses MMhe	* 2.82	Imperial MMhe	* 6.39	Dom avg MMhe	Total do	Heat from CHP (H/P = 1.413)
Jul	19	110	30	85	10	61	295	584	825
Aug	19	110	28	80	10	61	295	579	818
Sep	19	110	37	104	10	61	295	603	852
Oct	18	103	36	101	10	61	295	593	838
Nov	18	103	38	108	10	61	295	603	838
Dec	18	103	34	95	10	61	295	593	838
Jan	18	104	22	63	8	51	295	584	825
Feb	18	104	41	114	8	51	295	603	852
Mar	18	104	28	79	8	51	295	584	825
Apr	17	96	31	88	9	59	295	584	825
May	17	96	30	85	9	59	295	584	825
Jun	17	96	26	74	9	59	295	584	825
								8930	12618

ST. P./TORTEVAL SUPPLEMENTARY HEAT REQUIREMENT

	Corr	Total
Jul	-133	207
Aug	-336	4
Sep	75	414
Oct	1796	2815
Nov	1953	2973
Dec	2460	3479
Jan	3139	4158
Feb	3056	4075
Mar	2812	3632
Apr	2037	2377
May	1086	1426
Jun	347	687
	18760	26446

ESCO monthly heat averages  
(Forest)

FOREST SEASONAL HEAT												
	Airport MWh	#1.55	S. Flowers MWh	#1.71	M. C. C. MWh	#3.1	Dom avg MWh	100% Dom MWh	Total non-Dom MWh	80% Eff MWh	Corr MWh	Total ESCO MWh
Jul	21	33	0	0	21	66	636	310	98	79	60	370
Aug	18	28	0	0	21	66	636	310	94	75	57	367
Sep	20	30	95	163	27	82	636	310	276	220	169	479
Oct	51	79	191	326	42	131	1908	929	537	430	329	1258
Nov	91	142	265	453	42	131	1908	929	726	581	445	1374
Dec	109	169	424	725	42	131	1908	929	1026	821	628	1557
Jan	115	178	636	1088	42	131	1908	929	1397	1118	856	1785
Feb	118	183	689	1178	42	131	1908	929	1493	1194	914	1844
Mar	96	149	848	1450	42	131	1908	929	1730	1384	1060	1989
Apr	82	128	530	906	27	82	636	310	1116	893	683	993
May	63	98	212	363	27	82	636	310	543	434	333	642
Jun	29	45	0	0	21	66	636	310	110	88	68	377
								7434		7317	5601	13035

FOREST SEASONAL POWER											
	Airport MkWh	#1.55	S. Flowers MkWh	#1.71	Mallard C. C. MkWh	#3.1	Dom avg MkWh	Total Dom MkWh	Total non-Dom MkWh	Heat from CHP (H/P = 1.413)	Total MkWh
Jul	123	190	35	59	23	71	302	147	468	661	1071
Aug	125	194	35	59	24	74	302	147	474	670	1094
Sep	125	194	35	59	29	91	302	147	492	695	1187
Oct	126	196	62	106	25	77	302	147	526	743	1273
Nov	145	225	62	106	15	48	603	294	673	950	1623
Dec	152	235	62	106	15	45	603	294	681	962	1643
Jan	143	222	81	139	10	31	603	294	686	969	1655
Feb	190	294	81	139	12	38	603	294	765	1081	1846
Mar	149	231	81	139	10	30	603	294	694	980	1674
Apr	143	222	51	88	15	47	603	294	650	919	1569
May	155	239	51	88	13	42	302	147	516	729	1245
Jun	130	202	51	88	19	58	302	147	494	698	1192
									7118	10057	17175

FOREST SUPPLEMENTARY HEAT REQUIREMENT

	Corr	Total
non-Dom	-601	-291
ESCO	-612	-302
Jul	-526	-216
Aug	-414	515
Sep	-506	424
Oct	-334	595
Nov	-114	816
Dec	-167	762
Jan	79	1008
Feb	-235	74
Mar	-396	-86
Apr	-630	-321
May	79	4194
Jun		

ESCO monthly heat averages  
(St. Andrews)

ST. ANDREWS SEASONAL HEAT												
	Grammar	* 1.9	Angement	* 2.8	Dairy	* 1.2	Dom avg	79% Dom	Total non-Dom	80% Eff	Corr	Total ESCo
	Ml/h	Ml/h	Ml/h	Ml/h	Ml/h	Ml/h	Ml/h	Ml/h	Ml/h	Ml/h	Ml/h	Ml/h
Jul	90	171	64	178	279	334	636	399	664	547	419	818
Aug	90	171	64	178	191	229	636	399	578	463	354	754
Sep	180	342	127	356	191	229	636	399	928	742	568	967
Oct	175	332	191	534	238	286	1908	1198	1152	922	706	1904
Nov	270	514	265	742	191	229	1908	1198	1485	1188	909	2107
Dec	270	514	265	742	286	343	1908	1198	1599	1279	979	2178
Jan	360	685	265	742	286	343	1908	1198	1770	1416	1084	2282
Feb	451	856	265	742	170	204	1908	1198	1801	1441	1103	2302
Mar	270	514	265	742	270	324	1908	1198	1580	1264	968	2166
Apr	180	342	191	534	191	229	636	399	1106	884	677	1077
May	180	342	191	534	159	191	636	399	1067	854	654	1053
Jun	164	312	191	534	191	229	636	399	1075	860	659	1058
								9587	11860	11860	9079	18666

ST. ANDREWS SEASONAL POWER

ST. ANDREWS SEASONAL POWER												
	Grammar	* 1.9	Angement	* 2.8	Dairy	* 1.2	Dom avg	79% Dom	Total non-Dom	80% Eff	Corr	Total ESCo
	Ml/h	Ml/h	Ml/h	Ml/h	Ml/h	Ml/h	Ml/h	Ml/h	Ml/h	Ml/h	Ml/h	Ml/h
Jul	76	145	17	49	45	54	296	235	482	661	661	1866
Aug	70	133	17	49	48	58	296	235	475	671	671	1866
Sep	50	94	17	49	55	66	296	235	444	628	628	1866
Oct	77	146	18	50	51	61	296	235	492	695	695	1866
Nov	81	153	18	50	51	62	593	471	736	1040	1040	1866
Dec	92	174	18	50	51	62	593	471	757	1070	1070	1866
Jan	83	157	15	41	41	50	593	471	720	1017	1017	1866
Feb	102	193	15	41	77	93	593	471	799	1129	1129	1866
Mar	89	168	15	41	46	56	593	471	737	1041	1041	1866
Apr	92	175	15	43	60	72	593	471	762	1076	1076	1866
May	85	161	15	43	72	87	296	235	526	743	743	1866
Jun	87	165	15	43	63	76	296	235	519	734	734	1866
									7448	11860	9079	18666

ST. ANDREWS SUPPLEMENTARY HEAT REQUIREMENT

	Grammar	* 1.9	Angement	* 2.8	Dairy	* 1.2	Dom avg	79% Dom	Total non-Dom	80% Eff	Corr	Total ESCo
	Ml/h	Ml/h	Ml/h	Ml/h	Ml/h	Ml/h	Ml/h	Ml/h	Ml/h	Ml/h	Ml/h	Ml/h
Jul	76	145	17	49	45	54	296	235	482	661	661	1866
Aug	70	133	17	49	48	58	296	235	475	671	671	1866
Sep	50	94	17	49	55	66	296	235	444	628	628	1866
Oct	77	146	18	50	51	61	296	235	492	695	695	1866
Nov	81	153	18	50	51	62	593	471	736	1040	1040	1866
Dec	92	174	18	50	51	62	593	471	757	1070	1070	1866
Jan	83	157	15	41	41	50	593	471	720	1017	1017	1866
Feb	102	193	15	41	77	93	593	471	799	1129	1129	1866
Mar	89	168	15	41	46	56	593	471	737	1041	1041	1866
Apr	92	175	15	43	60	72	593	471	762	1076	1076	1866
May	85	161	15	43	72	87	296	235	526	743	743	1866
Jun	87	165	15	43	63	76	296	235	519	734	734	1866
									7448	11860	9079	18666

ESCO Monthly heat averages  
(St. Martins)

ST. MARTINS SEASONAL HEAT											
PEH	* 3.2	Bali-Hai	* 2.5	St. Margarets	L	Dom avg	89%	Total	80% Eff	Corr	Total
MWh	MWh	MWh	MWh	MWh	MWh	MWh	Dom	non-Dom	MWh	MWh	ESCO
							MWh	MWh			MWh
Jul	530	1696	48	119	20	258	1232	2073	1658	1270	2501
Aug	382	1221	48	119	25	322	1232	1662	1330	1018	2250
Sep	191	611	95	239	23	291	1232	1140	912	698	1930
Oct	571	1828	143	358	42	539	3695	2725	2180	1669	5364
Nov	1049	3358	191	477	47	596	3695	4431	3545	2713	6408
Dec	1049	3358	191	477	54	697	3695	4532	3626	2775	6471
Jan	571	1828	191	477	19	248	3695	2553	2043	1564	5259
Feb	1147	3670	191	477	29	373	3695	4520	3616	2768	6463
Mar	562	1798	191	477	47	597	3695	2872	2297	1759	5454
Apr	764	2446	143	358	62	799	1232	3603	2882	2206	3438
May	956	3060	95	239	27	346	1232	3644	2915	2232	3463
Jun	572	1832	48	119	24	312	1232	2263	1810	1386	2618
							29561		28814	22057	51618

ST. MARTINS SEASONAL POWER											
PEH	* 3.2	Bali-Hai	* 2.5	St. Margarets	L	Dom avg	89%	Total	Heat from	Corr	Total
MWh	MWh	MWh	MWh	MWh	MWh	MWh	Dom	non-Dom	CHP	MWh	ESCO
							MWh	MWh	(H/P = 1.413)		MWh
Jul	130	416	4	11	21	272	284	1316	1860	1270	2501
Aug	141	451	4	11	21	272	284	1352	1910	1018	2250
Sep	143	458	4	11	21	272	284	1358	1919	698	1930
Oct	138	443	5	13	22	285	284	1359	1920	1669	5364
Nov	156	499	5	13	22	285	569	2035	2875	2713	6408
Dec	160	511	5	13	22	285	569	2047	2892	2775	6471
Jan	154	492	108	270	22	283	569	2284	3227	1564	5259
Feb	202	646	108	270	22	283	569	2438	3445	2768	6463
Mar	160	510	108	270	22	283	569	2302	3253	1759	5454
Apr	159	509	5	13	22	284	569	2044	2888	2206	3438
May	168	537	5	13	22	284	569	1452	2052	2232	3463
Jun	146	466	5	13	22	284	284	1381	1951	1386	2618
								21367	30191	22057	51618

ST. MARTINS SUPPLEMENTARY HEAT REQUIREMENT

Corr	Total
non-Dom	ESCO
Jul	641
Aug	339
Sep	11
Oct	3444
Nov	3533
Dec	3579
Jan	2032
Feb	3018
Mar	2201
Apr	550
May	1412
Jun	666
	180
	21426

ST. PETER PORT SEASONAL HEAT

	Beau Sejour Mlht	Ramee R * 28.5 Mlht	St. Pierre P * 1.8 Mlht	Intersurgical * 3.5 Mlht	Dom avg Mlht	100% Dom Mlht	Total non-Dom Mlht	80% Eff Mlht	Corr Mlht	Total ESCo Mlht
Jul	85	212	382	0	636	4028	3253	2603	1992	6020
Aug	85	2417	362	0	636	4028	3114	2491	1907	5935
Sep	95	2719	382	0	636	4028	3644	2915	2231	6259
Oct	117	3323	382	34	1908	12083	4795	3836	2936	15020
Nov	133	3776	382	98	1908	12083	4979	3984	3049	15133
Dec	265	7553	572	275	1908	12083	9761	7809	5978	18061
Jan	318	9063	572	338	1908	12083	11346	9077	6948	19032
Feb	345	9818	382	288	1908	12083	11871	9497	7270	19353
Mar	345	9818	382	286	1908	12083	11873	9498	7271	19354
Apr	212	6042	382	201	636	4028	7659	6127	4690	8718
May	117	3323	382	171	636	4028	4559	3647	2792	6620
Jun	106	3021	382	163	636	4028	4215	3372	2561	6609
						96667		64856	49647	146314

ST. PETER PORT SEASONAL POWER

	Beau Sejour Mlht	Ramee Roses * 28.5 Mlht	St. Pierre Park * 1.8 Mlht	Intersurgical * 3.5 Mlht	Dom avg Mlht	100% Dom Mlht	Total non-Dom Mlht	80% Eff Mlht	Corr Mlht	Total ESCo Mlht
Jul	109	3110	27	81	260	1647	5769	8152		
Aug	124	3528	35	79	260	1647	6233	8807		
Sep	119	3392	43	87	260	1647	6125	8655		
Oct	111	3167	0	83	260	1647	5767	8149		
Nov	122	3486	26	80	521	3299	7816	11044		
Dec	131	3721	31	95	521	3299	8017	11329		
Jan	113	3210	42	57	521	3299	7335	10364		
Feb	130	3698	42	84	521	3299	7955	11240		
Mar	119	3382	30	90	521	3299	7493	10587		
Apr	126	3593	32	102	521	3299	7817	11045		
May	137	3916	36	79	260	1647	6644	9388		
Jun	123	3513	29	86	260	1647	6306	8911		
							83277	117671		

ST. PETER PORT SUPPLEMENTARY HEAT REQUIREMENT

	Corr	Total
Jul	-6159	-2132
Aug	-6900	-2872
Sep	-6424	-2396
Oct	-5213	6871
Nov	-7994	4089
Dec	-5351	6732
Jan	-3416	8667
Feb	-3970	8113
Mar	-3316	8767
Apr	-6355	-2327
May	-6596	-2568
Jun	-6329	-2301
	0	43240

ESCo monthly heat averages  
(St. Peter Port)

Heat from CHP  
Mlht  
(H/P = 1.413)

**APPENDIX M**

Sample diurnal heat profiles to back-up assertions on  
'peak', 'base load' and 'expected' (probabilistic)  
incomes from cogeneration

(1) Typical VINERY diurnal heat profile<sup>1</sup>

Typical VINERY diurnal heat profile

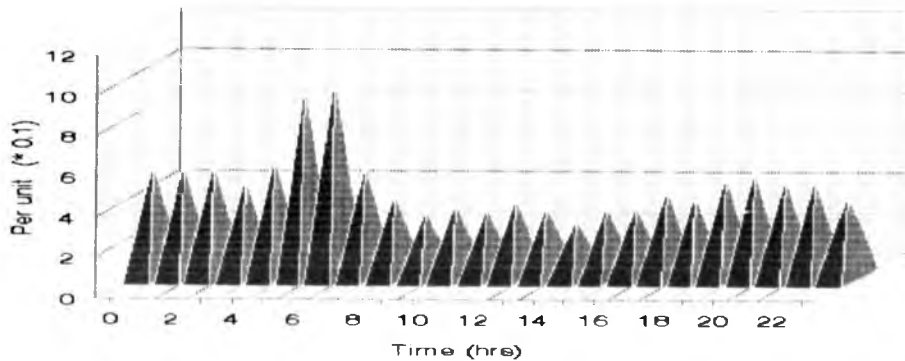

Figure 203

(2) Typical DOMESTIC diurnal heat profile<sup>2</sup>

Typical DOMESTIC diurnal heat profile

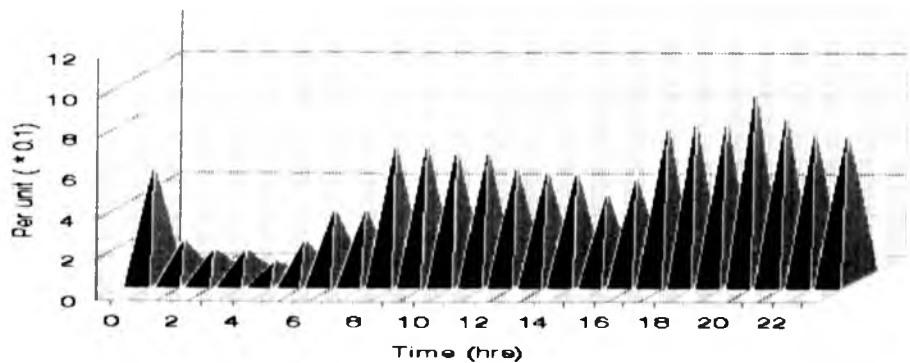

Figure 204

1. Measurements undertaken by Utilicom Limited for the SEB in 1983.
2. 'Direct Acting Space Heating (DASH)' profile (42 F) provided by the U.K. Electricity Association.



(3) Typical HOSPITAL diurnal heat profile<sup>1</sup>

**Typical diurnal heat profile at  
Princess Elizabeth HOSPITAL**

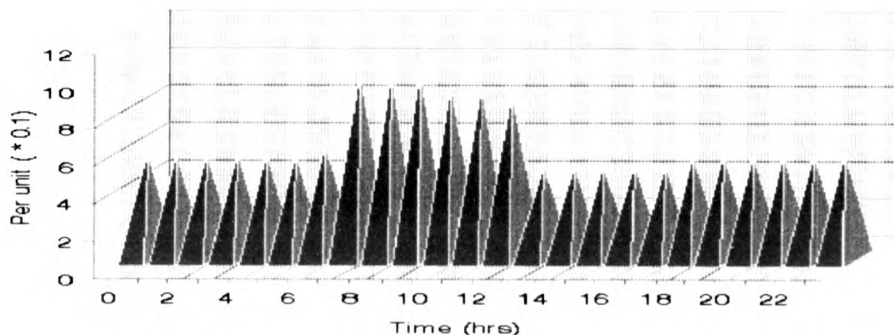

Figure 205

(4) Typical BEAU SEJOUR diurnal heat profile<sup>2</sup>

**Typical diurnal heat profile at  
BEAU SEJOUR**

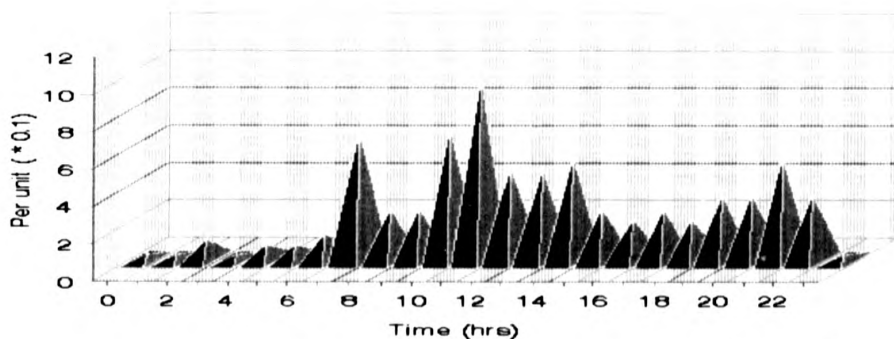

Figure 206

1. P.E. Hospital - survey 23-24 November 1994.

2. Beau Sejour - survey 28-29 November 1994.

**APPENDIX N**

Probable ESCo composite (maximum) diurnal heat profiles

Vale ESCo<sup>1</sup>

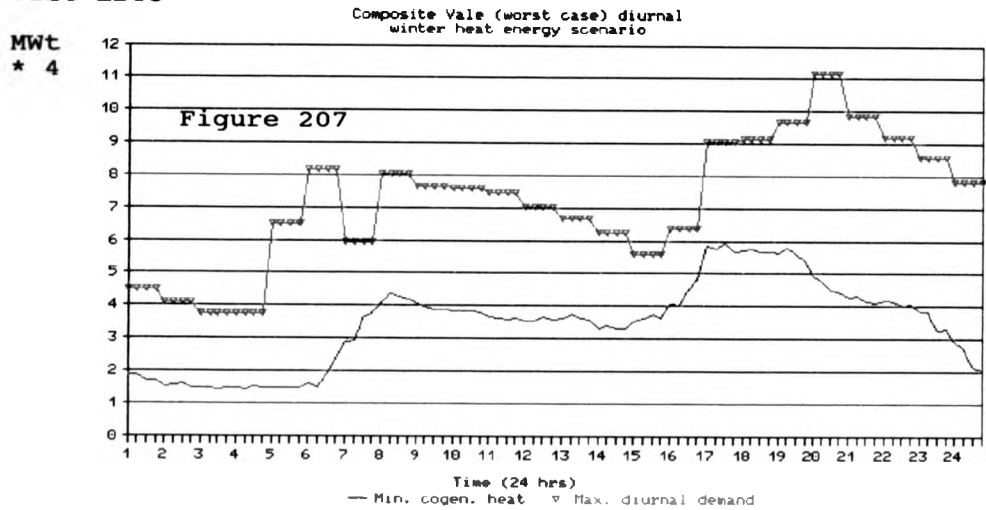

St. Sampson's ESCo<sup>2</sup>

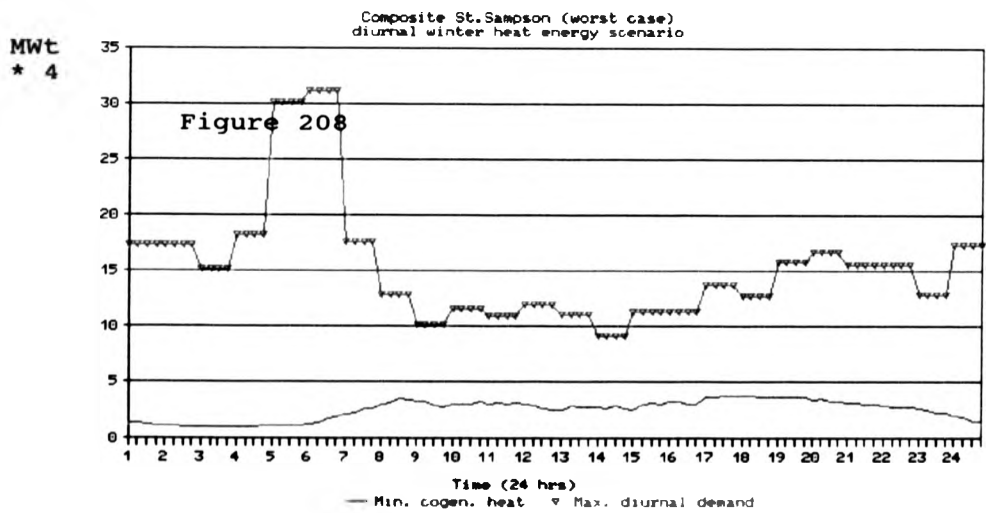

1. Supplementary heat boiler proposal 28 MWt.
2. Supplementary heat boiler proposal 120 MWt.

### Castel ESCo<sup>1</sup>

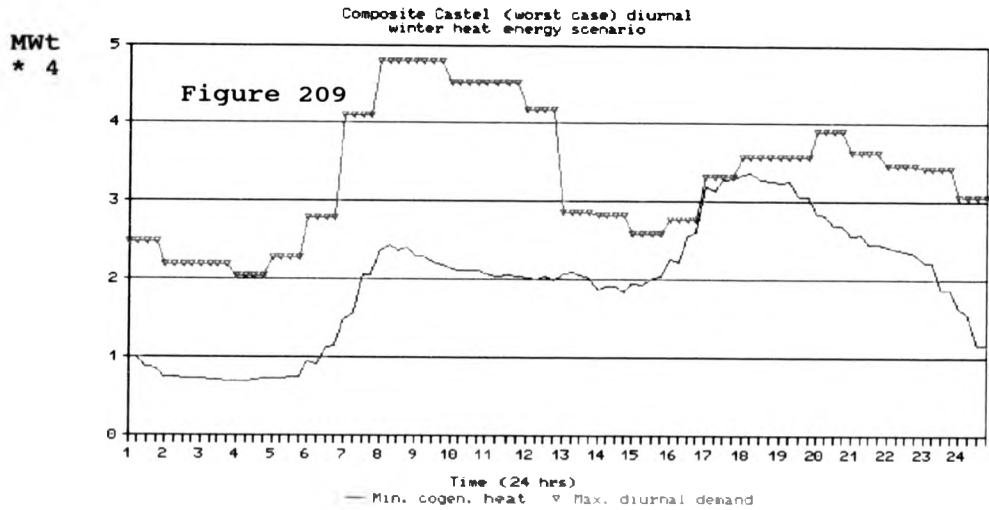

### St.Saviour's ESCo<sup>2</sup>

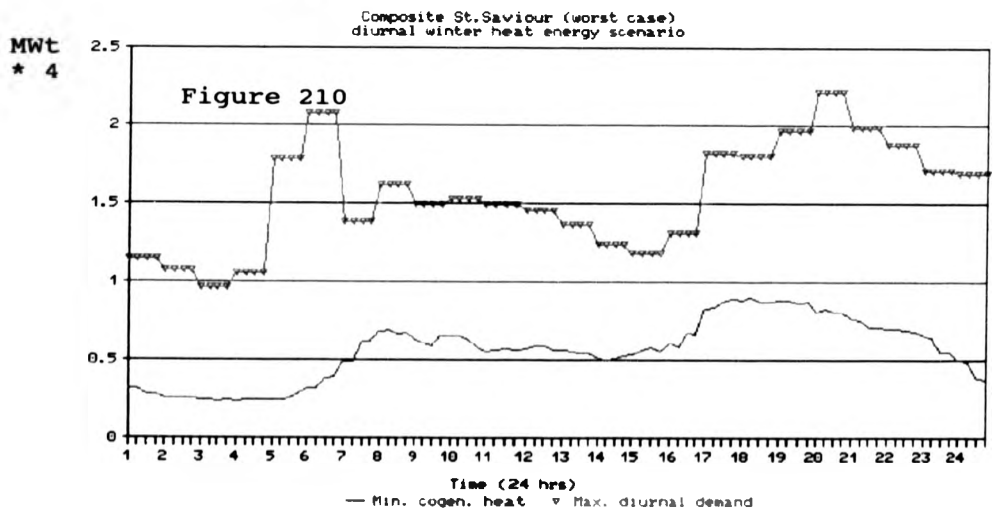

1. Supplementary heat boiler proposal 12 MWt.
2. Supplementary heat boiler proposal 8 MWt.

### St. Peter/Torteval ESCo<sup>1</sup>

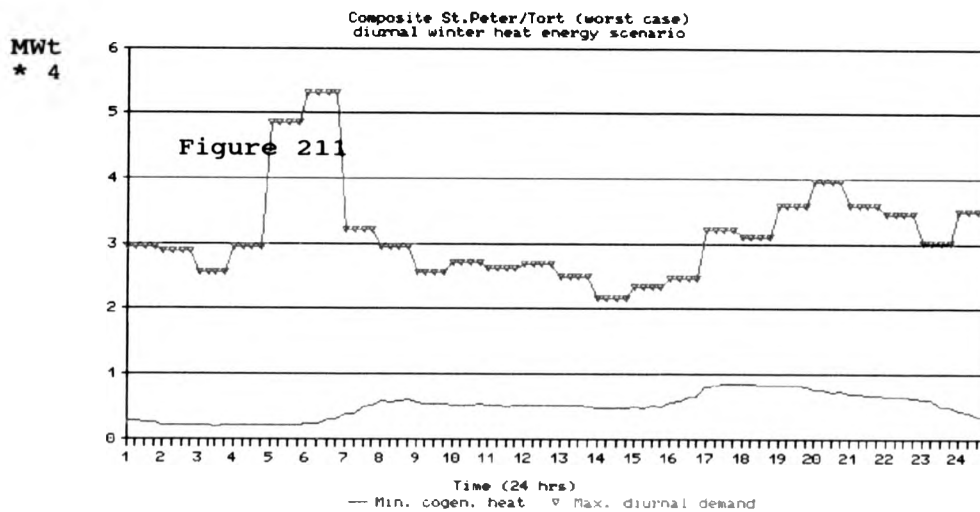

### St. Andrew's ESCo<sup>2</sup>

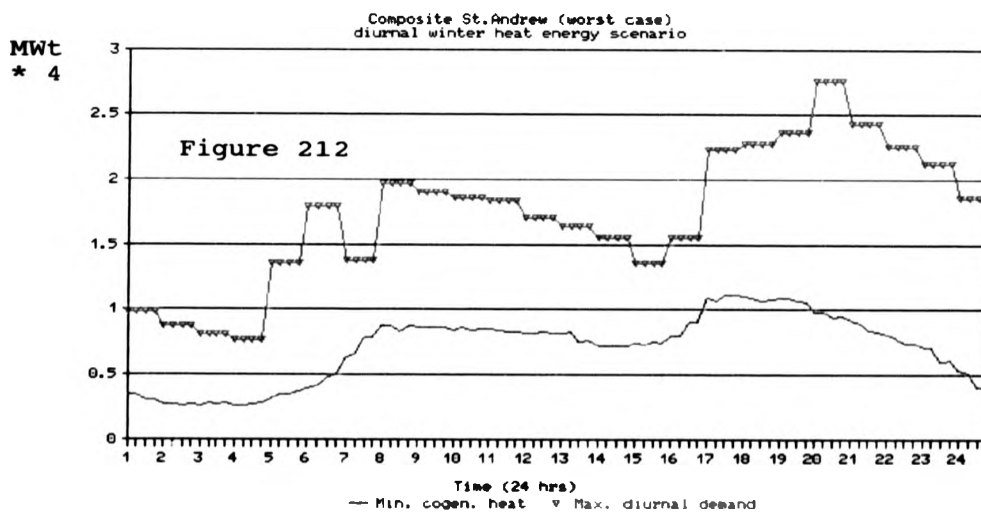

1. Supplementary heat boiler proposal 20 MWt.
2. Supplementary heat boiler proposal 7 MWt.

### St.Martin's ESCo<sup>1</sup>

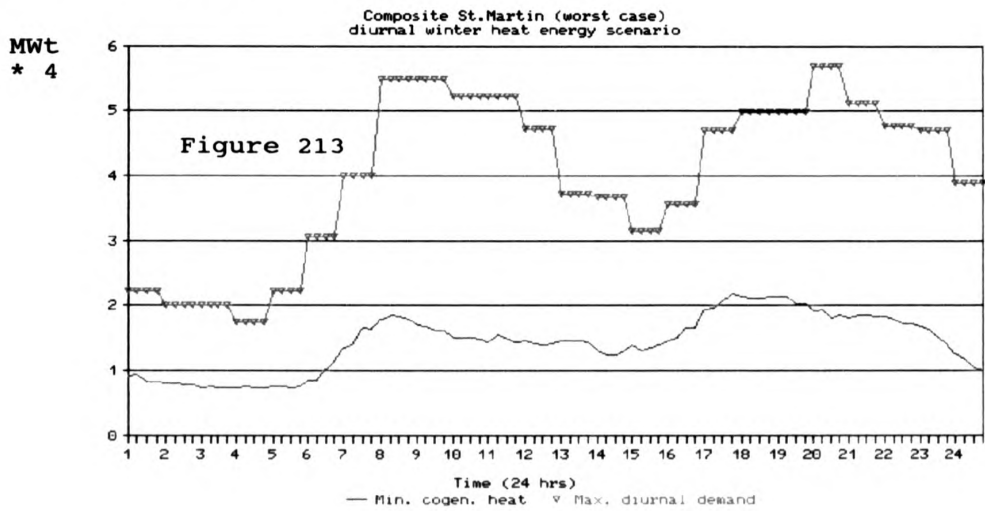

### St.Peter Port ESCo<sup>2</sup>

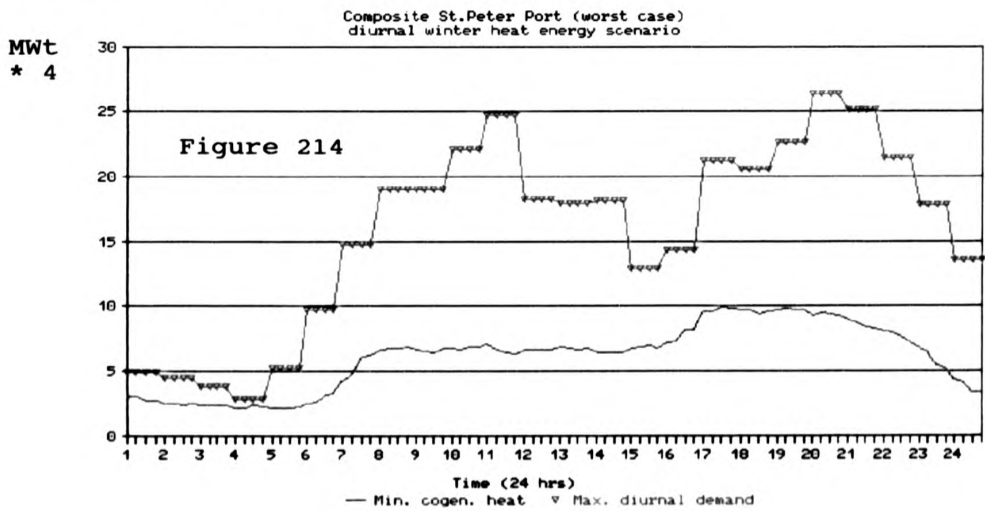

1. Supplementary heat boiler proposal 16 MWt.
2. Supplementary heat boiler proposal 72 MWt.

**BIBLIOGRAPHY**

WORKS CITED BY CHAPTER

WORKS CITED - CHAPTER 1

ADVISORY AND FINANCE COMMITTEE,  
Billet d'Etat,  
vol. VII: 1967, p. 10.

ADVISORY AND FINANCE COMMITTEE,  
Billet d'Etat,  
14 July 1988.

ADVISORY AND FINANCE COMMITTEE,  
"Guernsey the European Community and 1992", 1992.

ADVISORY AND FINANCE COMMITTEE,  
Billet d'Etat, XVI,  
26 September 1990.

ANSTEAD D.T., LATHAM R.J.,  
"The Channel Islands", 1893.

BARRE O,  
"Origines Tectoniques du Golfe de St.Malo", 1905.

BERRY Wm,  
"The history of the island of Guernsey, from the remotest  
period of antiquity to the year 1814", 1815.  
Containing an interesting account of the Island, its  
government, civil, ecclesiastical and military.

BOLLAND H,  
"Les Iles de la Manche", 1904.

CAREY E,  
"The Channel Islands", 1904.

CARTY P,  
"Troubled Water",  
Accountancy,  
October 1993.

CHESHIRE J,  
"The pace of change",  
Applied Energy Elsevier Sc., 1992.

CHRISTENSEN L.R., GREENE W.H.,  
"Economies of scale in U.S. electric power generation",  
Journal of political economy,  
vol. 84: 1976, pp. 655-676.



CROOK A.W.,  
"Profiting from low-grade heat",  
IEE Energy Series,  
vol. 7: 1994.  
Published on behalf of the Watt Committee on energy - Report  
No 261  
ISBN: 0-85296-835-5  
See also preprint published on behalf of the Watt Committee  
on energy by Brunel University - 26 February 1991.

DEMANGEON A,  
"Les Isles Britanniques",  
Geographie, Universelle, Publie par Vidal de la blanche et  
L.Gallois,  
vol. 1: 1927.

DICEY T,  
"An historical account of the island of Guernsey", 1777.

DURAND R,  
"Guernsey present and past", 1932.

DUNCAN J,  
"The history of Guernsey", 1841.

ELECTRICAL REVIEW,  
"Pocket-size power packs potential",  
Electrical Review,  
vol. 224: no3, 8-21 February 1991.

EWBANK PREECE LIMITED,  
"Brief review of the SEB's future energy policy options",  
15 April-10 May 1985.

GUERNSEY EVENING PRESS,  
"Electricity report is welcomed by Board President",  
6 February 1982.

GUERNSEY EVENING PRESS,  
"Friends of the Earth want an Island energy policy",  
14 September 1990.

HAFELE W,  
"Energy in a finite world",  
Ballinger Publishing Company, 1981, 755-767 pp.  
The hard-soft controversy

HEDLEY D,  
"World energy: The facts and the future",  
Euromonitor Publications, 1986.  
ISBN: 0-8160-1615-1

JACQUES J.K., LESOURD J.B., RUIZ J.M.,  
"Modern applied energy conservation",  
Ellis Horwood, 1988.  
ISBN: 0-7458-0268-0

JENKINS N,  
"It is energy we need not electricity",  
Energy Policy,  
June 1990.

LOVINS A.B.,  
"Soft energy paths: Towards a durable peace",  
ISBN: 0-88410-615-2,  
Friends of the Earth, Penguin, 1977.

NERLOVE M,  
"Returns to scale in electricity supply", 1963.

NORWEB/ETSU,  
"Joint study by Norweb and ETSU",  
Quarterly Journal of Renewable Energy,  
vol. 9: Autumn 1989.

STATES ELECTRICITY BOARD,  
"Energy policy memorandum 23/84", 1984.

STATES ELECTRICITY BOARD,  
"SEB News", 1989.

SEMPLE F.C.,  
"Influences of geographic environment", .

STATES OF GUERNSEY,  
"Guernsey census 1991", 1991.

TOMBS F,  
"Economies of scale in electricity generation and  
transmission since 1945",  
Proceedings of the Institution of Mechanical Engineers,  
vol. 192: 1978.

TUPPER F.B.,  
"The history of Guernsey and its Bailiwick", 1876.

TWIDELL, J.W AND PINNEY, A.A.,  
"The quality and exergy of energy systems, using  
conventional and renewable resources",  
Energy Studies Unit, University of Strathclyde, Glasgow,  
1987.

WARREN J.P.,  
"Our own Island", 1926.

WILLS R.J.,  
"Slow-speed diesels for electricity supply",  
Utilities Policy,  
October 1990.

WILLS R.J.,  
"New local diesel power stations",  
Utilities Policy,  
vol. 2: April 1992.

**COLLECTED DOCUMENTS - CHAPTER 1**

ADVISORY AND FINANCE COMMITTEE,  
"States of Guernsey statistical digest - all years to 1993",  
1993.

DEPARTMENT OF ENERGY (U.K.),  
"Privatising Electricity: the Government's proposals for the  
privatisation of the Electricity Supply Industry in England  
and Wales",  
London, HMSO - Command Paper 322, 1988.

DEPARTMENT FOR SCOTLAND,  
"Privatisation of the Scottish Electricity Industry",  
London, HMSO - Command Paper 327, 1988.

HAMMOND C.J.,  
"Privatisation and the efficiency of decentralised  
electricity generation: some evidence from inter-war  
Britain",  
University of Hull, 1989.

HANNAH L,  
"Electricity before nationalisation",  
London, Macmillan, 1979.

PERRY R.S.,  
"Perry's guide maps of Guernsey, Herm and Sark",  
Prism, Guernsey, 1990.

STATES OF GUERNSEY,  
"Guernsey census 1981", 1981.

STATES OF GUERNSEY,  
"Guernsey census 1986", 1986.

**WORKS CITED - CHAPTER 2**

ADVISORY AND FINANCE COMMITTEE,  
Billet d'Etat,  
July 1988, p. 594.

ADVISORY AND FINANCE COMMITTEE,  
"1991 Policy Planning, Economic and Financial Report", 1991.

ATKINS W.S. AND MERZ & MCLELLAN,  
"The Jersey energy supply study", 1989.

BARBOUR D.W.,  
"Energy supply for the island of North Ronaldsay, Orkney",  
1983.  
Thesis submitted to the University of Strathclyde for the  
Degree of Master of Science in Applied Physics.

CURRAN J.S.,  
"Energy and human needs",  
1979,  
Scot Acad Press.

ECONOMIST,  
"Britain is launched on an audacious experiment in energy  
policy: not to have one",  
Economist,  
21 August 1993.

GUERNSEY EVENING PRESS,  
"Nuclear industry like a cancer on this earth",  
Report on States of Deliberation debate,  
2 August 1985.

GUERNSEY EVENING PRESS,  
"High cost of heating contributes to glasshouse area  
decline",  
20 February 1986.

HORTICULTURAL ADVISORY SERVICE,  
"A strategic overview of Guernsey Horticulture -  
Consultation document", 1987.

KILSHAW Rev.Wm.,  
"Historic windmill sites",  
St.John's vicarage.

KONIS C.Y.,  
"Energy management and conservation in the hotel industry of  
Cyprus",  
University of Stirling, PhD thesis, 1991.

LANGLOIS J.E.,  
"Horticulture - what of the future ?",  
Guernsey Growers Association - Annual Report and Year  
Book.

OFFICE FOR OFFICIAL PUBLICATIONS OF THE E.U.,  
"Portrait of the islands",  
A detailed description of the 440 inhabited islands in the  
European Union.

PEAT MARWICK MCLINTOCK.,  
"Economic appraisal of Guernsey", 1987.

SLESSER M,  
"Energy in the economy"

STATES OF GUERNSEY,  
"Technical services department (Architectural division)  
Annual Report", 1989.

UNDP/WORLD BANK,  
"Seychelles: Issues and options in the energy sector", 1984.  
UNDP/World Bank energy sector assessment program - Report  
No. 4693-SEY.

WESTERN ISLES ISLANDS COUNCIL,  
"Towards an energy charter and network for European  
islands", 1993.  
European Services, Western Isles Islands Council, Stornoway,  
Western Isles, Scotland.  
A report prepared by the Western Isles Islands Council on  
behalf of the Islands Commission of the Conference of  
Peripheral Maritime Regions for DGXVII of the European  
Commission.

COLLECTED DOCUMENTS (ENERGY AND SMALL ISLANDS) - CHAPTER 2

BYER T, RICHTER J, VARDI J,  
"Energy development in the Caribbean - options and  
necessities",  
Energy Policy,  
December 1980.  
Covering the islands of Antigua, Barbados, Belize, Dominica,  
Dominican Republic, Grenada, Guyana, Haiti, Jamaica,  
Montserrat, St.Kitts, St.Lucia and St.Vincent.

FESHARAKI F, ISAAK D.T.,  
"Global trends and structural changes in the world oil  
market: Questions for the Pacific islands", 1982.  
Honolulu, Hawaii, Resource Systems Institute, East-West  
Center.

SOCIETY FOR UNDERWATER TECHNOLOGY,  
"Energy for islands",  
Graham and Trotman Limited, 1988.  
ISBN: 1-85333-056-6

UNDP/WORLD BANK,  
"Indonesia: Issues and options in the energy sector", 1981,  
126 pp.  
Joint UNDP/World Bank energy sector assessment programme

UNDP/WORLD BANK,  
"Haiti: Issues and options in the energy sector", 1982,  
100 pp.  
Joint UNDP/World Bank energy sector assessment programme

UNDP/WORLD BANK,  
"Papua New Guinea: Issues and options in the energy sector",  
1982, 96 pp.  
Joint UNDP/World Bank energy sector assessment programme

UNDP/WORLD BANK,  
"Fiji: Issues and options in the energy sector", 1983,  
48 pp.  
Joint UNDP/World Bank energy sector assessment programme

UNDP/WORLD BANK,  
"Solomon Islands: Issues and options in the energy sector",  
1983, 59 pp.  
Joint UNDP/World Bank energy sector assessment programme

UNDP/WORLD BANK,  
"Sri Lanka: Issues and options in the energy sector", 1983,  
126 pp.  
Joint UNDP/World Bank energy sector assessment programme

UNITED NATIONS,  
"Coastal area resource development: Energy in small  
islands", 1986.  
ISBN: 92-1-104220-8

#### COLLECTED DOCUMENTS (WORLD ENERGY RESOURCES) - CHAPTER 2

BRITISH PETROLEUM,  
"BP Statistical Review of World Energy",  
London, British Petroleum Company.  
Various issues

CLARK J.G.,  
"The political economy of world energy",  
Harvester Wheatsheaf, 1990.

ECONOMIST,  
"Slurp, Burp",  
17 July 1993.

DAS, S, LEIBY, P AND LEE, R,  
"Oil markets under political and military stress",  
Energy Economics.

FRIENDS OF THE EARTH,  
"Energy without end", 1991.  
ISBN: 0-905966-87-2

FULKERSON W, JUDKINS R.R., SANGHVI M.K.,  
"Energy from fossil fuels - Energy for planet earth",  
W.H. Freeman & Co, New York, 1991.

WORLD ENERGY COUNCIL COMMISSION,  
"Energy for tomorrow's world",  
Kogan Page, 1993,  
ISBN: 07494-1117-1.

WORLD RESOURCES INSTITUTE/INTERNATIONAL INSTITUTE FOR  
ENVIRONMENT AND DEVELOPMENT,  
"World resources 1988-89: An assessment of the resource base  
that supports the global economy", 1989.

WORKS CITED - CHAPTER 3

ACKOFF, R.L.,  
"Redesigning the future",  
Wiley, New York, 1974.

BEISHON, J AND PETERS, G,  
"Systems behaviour",  
The Open University, 1972,  
ISBN: 06-318011-1.

CHECKLAND P.B.,  
"Systems Thinking, Systems Practice",  
John Wiley & Sons Limited, 1981.  
ISBN: 0-471-27911-0

CHECKLAND P.B., SCHOLLES J,  
"Soft systems methodology in action",  
John Wiley and Sons Limited, 1990.  
ISBN: 0-471-92768-6

DEPARTMENT OF SYSTEMS,  
"List of PhD theses 1970-89",  
University of Lancaster, Bailrigg, Lancaster.

FLOOD, R. L AND JACKSON, M.C,  
"Creative problem solving",  
John Wiley and Sons, 1991,  
ISBN: 0-471-93052-0.

GREENBERGER M, BREWER G.D., HOGAN W.W. et al.,  
"Caught unawares: The energy decade in retrospect",  
Ballinger, Cambridge, Ma., 1983.

HU, S.D,  
"Cogeneration",  
Reston Publishing Company Inc., 1985,  
ISBN: 0-8359-0771-6.

JACQUES, J.K AND KONIS, C.Y (WITH COMPUTER TECHNICAL  
ASSISTANCE FROM MUIR, A AND MITCHELL, C),  
"Systems modelling and micro-computing applied to  
mediterranean hotel energy conservation planning through  
cogeneration simulations", 7 September 1989.  
Paper presented at Institute of Energy meeting, Swansea.

JENKINS G.M.,  
"On the definition of 'systems' in systems engineering -  
some comments",  
Journal of System Engineering,  
vol. 2: no2, 1971.

OPTNER S.L.,  
"Systems analysis for business and industrial problem  
solving", 1965.

WATSON R, SMITH R,  
"Applications of Lancaster Soft Systems Methodology in  
Australia",  
Journal of Applied Systems Analysis,  
vol. 15: 1988.

WILSON B,  
"Systems: Concepts, methodologies and applications",  
John Wiley and Sons Limited, 1984.  
ISBN: 0-471-90443-0

#### COLLECTED DOCUMENTS - CHAPTER 3

CHECKLAND P.B.,  
"Techniques in 'soft' systems practice part 1: Systems  
Diagrams - some tentative guidelines",  
Journal of Applied Systems Analysis,  
vol. 6: 1979.

CHECKLAND P.B.,  
"Techniques in 'soft' systems practice part 2: Building  
Conceptual Models",  
Journal of Applied Systems Analysis,  
vol. 6: 1979.

CHECKLAND P.B., DAVIES L,  
"The use of the term 'WELTANSCHAUUNG' in soft systems  
methodology",  
Journal of Applied Systems Analysis,  
vol. 13: 1986.

JACKSON M.C.,  
"The nature of 'soft' systems thinking: The work of  
Churchman, Ackoff and Checkland",  
Journal of Applied Systems Analysis,  
vol. 9: 1982.

PATCHING D,  
"Practical soft systems analysis",  
Pitman, 1990.  
ISBN: 0-273-03237-2

SENGE P.M.,  
"The fifth discipline", 1990.  
ISBN: 0-7126-5687-1

SMYTH D.S., CHECKLAND P.B.,  
"Using a systems approach: The structure of Root  
Definitions",  
Journal of Applied Systems Analysis,  
vol. 5: no1, 1976.

VICKERS G,  
"The poverty of problem solving",  
Journal of Applied Systems Analysis,  
vol. 8: 1981.



WOODBURN I,  
"Some developments in the building of Conceptual Models",  
Journal of Applied Systems Analysis,  
vol. 12: 1985.

WOODBURN I,  
"The idea of 'system' and its use in 'hard' and 'soft'  
systems approaches",  
Journal of Applied Systems Analysis,  
vol. 15: 1988.

#### WORKS CITED - CHAPTER 4

ALDERNEY ELECTRICITY LIMITED,  
"Annual Report and Accounts for 1988", 1988,  
Alderney Electricity Limited, Maison des Venelles,  
Venelles des Gaudion, Alderney.

ARMSTRONG H, JOHNES G, JOHNES J et al.,  
"An analysis of costs and prices on the Isle of Man",  
University of Lancaster, 1990,  
Department of Economics, The Management School, University  
of Lancaster, Bailrigg, Lancaster, LA1 4YX

BRITISH FUELS LIMITED,  
"Coal pricing data", 1992.  
British Fuels Limited, The coal yard, La Hure Mare,  
Northside, Vale, Guernsey.

BLACK, GEOGHEGAN AND TILL,  
"States of Guernsey Electricity Board - Auditors' Report -  
1 April 1988 to 31 March 1989", 1989.  
Black, Geoghegan and Till, 10 Lefebvre Street, St.Peter  
Port, Guernsey.

BRITISH PETROLEUM,  
"Oil pricing data", 1992.  
British Petroleum Limited, Channel Oil Limited, Bulwer  
Avenue, St.Sampsons, Guernsey.

BRITISH GAS,  
"Techno-economic feasibility study for Gas Energy (CI)  
Limited", 1989.  
Interim Report - British Gas plc Technology Transfer

BRITISH GAS,  
"Techno-economic feasibility study for Gas Energy (CI)  
Limited", 1990.  
Phase Two Report - British Gas plc Technology Transfer

ENERGY INFORMATION CENTRE,  
"Oils report - pricing evaluation and market intelligence  
service", 1990.  
Cambridge Information and Research Services Limited,  
4a St.Andrews Street, Cambridge, CB2 3AZ.

ESSO PETROLEUM LTD,  
"Oil pricing data", 1992.  
Esso Petroleum Limited, Guernsey Petroleum Distributers  
Limited, Bulwer Avenue, St.Sampsons, Guernsey.

GAS ENERGY (C.I.) LIMITED,  
"Gas pricing data", 1992.  
Gas Energy (C.I.) Limited, Sydney Vane House, Ru du  
Commerce, St.Peter Port, Guernsey.

GUERNSEY EVENING PRESS,  
General Manager of the SEB remark "Of course we realise that  
we could buy oil at spot prices in Rotterdam much cheaper  
than from the U.K. domestic market at present, but above  
all is the question of security of supply", 8 March 1982.

HARKER J.H., BACKHURST J.R.,  
"Fuels and Energy",  
Academic Press, 1981.

JERSEY ELECTRICITY COMPANY LIMITED,  
"Annual Report and Accounts for the period 3 October 1988 to  
1 October 1989", 1989.  
The Jersey Electricity Company Limited, Queen's Road,  
St.Helier, Jersey, JE4 8NY.

JOURNAL OF TRANSPORT, ECONOMICS AND POLICY,  
"The optimal ship size", 1985.

JOURNAL OF TRANSPORT, ECONOMICS AND POLICY,  
"Economics of trade density in liner shipping", 1985.

MANX ELECTRICITY AUTHORITY,  
"Annual report and accounts 1988/89", 1989,  
P.O. Box 177, Electricity House, Victoria Road, Douglas,  
Isle of Man.

REVIEW OF ECONOMICS AND STATISTICS,  
"Economics of scale of general cargo ships", 1978.

SARKIR S,  
"Fuels and Combustion",  
Sangam Books Limited, 1990.

STATES ELECTRICITY BOARD,  
"Generation cost report", 1992.  
Internal report; various issues.

STATES ELECTRICITY BOARD,  
"Annual Report and Accounts 1991/92", 1992.  
States Electricity Board, Electricity House, Northside,  
Vale, Guernsey.

SHELL U.K. LTD,  
"Oil pricing data", 1992.  
Shell U.K. Limited, Fuel Supplies (C.I.) Limited, Bulwer  
Avenue, St.Sampsons, Guernsey.

TOTAL (SARNIA) LTD ,  
"Oil pricing data", 1992.  
Total (Sarnia) Limited, Northside, Vale, Guernsey.

#### COLLECTED DOCUMENTS - CHAPTER 4

JERSEY ELECTRICITY COMPANY LIMITED,  
"Comparison of domestic tariffs between the twelve U.K.  
Regional Electricity Companies, Jersey, Guernsey and the  
Isle of Man", 1992.  
Personal communications.

PETROLEUM TIMES,  
"Energy Report", 1991.  
Petroleum Times, Earl House, Earl Street, Maidstone, Kent,  
ME14 1PE. Various issues.

STATES ELECTRICITY BOARD,  
"Annual Report and Accounts", .  
Various issues from early years to the present day.

THE ENERGY INFORMATION CENTRE,  
"Energy for industry and commerce",  
The Energy Information Centre, Quarterly Bulletin, .  
An independent group providing information services and  
advice to fuel buyers and users on the U.K. mainland.

#### WORKS CITED - CHAPTER 5

BRITISH GAS,  
"Techno-economic feasibility study for Gas Energy (C.I.)  
Limited", 1989.  
Interim Report - British Gas plc Technology Transfer

BRITISH GAS,  
"Techno-economic feasibility study for Gas Energy (C.I.)  
Limited", 1990.  
Phase Two Report - British Gas plc Technology Transfer

BRITISH PETROLEUM,  
"BP Statistical Review of World Energy 1990",  
BP Statistical Review of World Energy, .  
British Petroleum Company.

BROWN, R.P., FIELDEN, D., JACQUES, J.K,  
"Electric Vehicles: An alternative transportation system for  
Guernsey", 1992.  
A University of Stirling internal report.

EWBANK PREECE LIMITED,  
"A Review of Generation Development", 1989.  
Final Report - reference 80206/1334C.

GOAD CHAS E,  
"SAMISTAT - Profile report - Shop counts", 1990,  
Retail information specialist, Chas E Goad Limited,  
Salisbury Square, Old Hatfield, AL9 5BJ

LEACH G,  
"Energy and growth: A comparison of 13 industrial and  
developing countries", 1986.

PINNEY A.A.,  
"Planning energy systems for small, rural communities  
(including economic, technical and thermodynamic criteria)",  
1987, University of Strathclyde - PhD thesis.

STATES COMMITTEE FOR HORTICULTURE,  
"A strategic overview of Guernsey Horticulture -  
Consultation document", 1988.  
Followed from the economic appraisal of Guernsey by Peat  
Marwick McLintock (see Chapter 2 references).

STATES OF GUERNSEY TECHNICAL SERVICES DEPARTMENT,  
"Energy Flows", 1988.

#### WORKS CITED - CHAPTER 6

BENSON R.S.,  
"Advanced Engineering Thermodynamics", 1976.

ELCONTROL S.P.A.,  
"VIP System 3", 1990.  
Elcontrol s.p.a., Blocco 7 N.93, 40050 Funo Centergross (BO)  
Italy.

EVERITT B,  
"Cluster Analysis",  
Heinemann, 1974.

KOTAS T.J.,  
"The Exergy method of thermal plant analysis", 1985.

ROGERS G.F.C.,  
"Engineering Thermodynamics, Work and Heat Transfer", 1967.

SCRAGG D,  
"Means of identifying heat loads within a city", 1987.  
A paper presented at the Combined Heat and Power Assoc. 7th  
National Conference, July, 1987, Torquay.

SHERWIN K,  
"Introduction to Thermodynamics",  
Chapman Hall, 1993.  
ISBN: 0-412-47640-1

STATES OF GUERNSEY,  
"The Electricity Law 1933 and subsequent additions", 1933.

STATES OF GUERNSEY,  
"The Health, Safety and Welfare of Employees 1950 Law",  
1950.

STATES OF GUERNSEY,  
"The Safety of Employees (Misc. Provisions) Ordinance 1952",  
1952.

STATES OF GUERNSEY,  
"The Steam Boilers (Insurance) Ordinance 1952", 1952.

STATES OF GUERNSEY,  
"The Safety of Employees (First-Aid and Welfare) Ordinance  
1954", 1954.

STATES OF GUERNSEY,  
"The Safety of Employees (Electricity Provisions) Ordinance  
1956", 1956.

STATES OF GUERNSEY,  
"The Poisonous Substances (Guernsey) Law 1958", 1958.

STATES OF GUERNSEY,  
"The Safety of Employees (Woodworking Machinery) Ordinance  
1959", 1959.

STATES OF GUERNSEY,  
"The Island Development Law 1966", 1966.

STATES OF GUERNSEY,  
"The Public Highway Ordinance 1967", 1967.

STATES OF GUERNSEY,  
"The Health and Safety at Work (General) (Guernsey)  
Ordinance 1987", 1987.

VAN GOOL W, HOOGENDOORN A.J,  
"Basic aspects of Exergy analysis and Exergy optimisation",  
1990, Energy Science Project, Department of Inorganic  
Chemistry, Rijksuniversiteit, The Netherlands.

#### WORKS CITED - CHAPTER 7

ALLERA S,  
Load Research Manager, 1992.  
U.K. Electricity Association, personal communication.

ANDREWS D.C., LOWE R.J.,  
"The economics and relevance of medium, small and micro  
combined heat and power/district heating", 1983.  
Energy research group, The Open University, Milton Keynes,  
U.K..

BILL C,  
"The application of diesel engine and gas turbine prime movers to Combined Heat and Power", 1989,  
Of the Energy and Economics Division of Merz & McLellan, Newcastle-upon-Tyne. Paper presented at the Independent Power Generation Conference, Heathrow Park Hotel, London + personal communication.

CAPROS P, SAMOUILIDIS E,  
"Energy policy analysis",  
Energy Policy,  
February 1988.

COGENERATION SYSTEMS LIMITED,  
c/o Midlands Electricity Board, Worcester Division,  
Blackpole Road, Worcester, WR4 9TB, 1992.

DOOLEY T,  
"Pocket-size power packs potential",  
Electrical Review,  
vol. 224: no3, 1991.

HEIN K,  
"Local power and heat generation in Heidenheim and West Germany", 1982.  
Stadtwerke Heidenheim AG, 7920 Heidenheim, West Germany.

HORLOCK J.H.,  
"Cogeneration: Combined Heat and Power",  
Pergamon Books Limited, 1987.  
ISBN: 0-08-034796-7

KEMPTON W, NEIMAN M,  
"Energy efficiency: Perspectives on individual behaviour",  
1987.

MADSEN A.E.,  
"Optimising today's generator controls and planning for the future", 1989.  
The Independent Power Generation Conference, 26-27 Sept 89,  
Heathrow Park Hotel, London.

MANNE A.S., RICHELIS R.G.,  
"The EC proposal for combining carbon and energy taxes",  
1993, Energy Policy, Vol 21, no1, Butterworth-Heinemann Limited.

NEELAMKAVIL F,  
"Computer simulation and modelling",  
John Wiley and Sons Limited, 1987.  
ISBN: 0-471-91129-1

NEWBOROUGH M, PROBERT S.D.,  
"Intelligent automatic electrical load management for networks of major domestic appliances", 1990.

PIDD M,  
"Computer simulation in Management Science",  
John Wiley and Sons Limited, 1992.  
ISBN: 0-471-93462-3

PIKE R,  
"Answers without questions",  
The Accountant,  
vol. 187: October 1982.

COLLECTED DOCUMENTS (dBASE III Plus) - CHAPTER 7

ACKERMAN C,  
"Teach yourself dBASE III Plus",  
Osborne McGraw-Hill, 1990.

BYERS R.A.,  
"Everyman's database primer - Featuring dBASE III Plus",  
Ashton-Tate Publishing Group, 1986.  
ISBN: 0-912677-85-6

CARRABIS J.D.,  
"dBASE III Plus - Programmer's library",  
Howard W Sams and Company, 1987.  
ISBN: 0-672-22579-4

DE PACE M,  
"dBASE III Plus",  
BSP Professional Books, USA., 1987.

JONES E,  
"Using dBASE III Plus",  
Osborne McGraw-Hill, 1987.

LISKIN M,  
"dBASE II Plus made easy",  
Osborne McGraw-Hill, 1988.

ROBERT C,  
"Up and running with dBASE III Plus",  
Sybex Inc., 1991.

SIMPSON A,  
"Understanding dBASE III Plus",  
Sybex Inc., 1986.

SPENCE R,  
"Clipper programming guide",  
Microtrend Books, USA., 1986.

TILEY E.W.,  
"Using Clipper",  
Que Corporation, USA., 1992.

**COLLECTED DOCUMENTS (Computer modelling) - CHAPTER 7**

CARROLL T.O.,

"The use of microcomputers in the energy sector in developing countries", 1985.  
W.Averell Harriman College, State University of New York,  
Stony Brook, New York

COMPUTER ASSOCIATES ,

"SuperCalc - User's Guide - Version 5 reference manual",  
Computer Associates, 1989.  
Computer Associates, 183-187 Bath Road, Slough,  
Berkshire, SL1 4AA

FAWKES S.D, JACQUES J.K., LINELL C et al.,

"Practical modelling of micro combined heat and power applications for Local Authority district heating schemes",  
Energy Research, vol. 12.  
John Wiley and Sons Limited

HUTCHINSON R, MCBRIEN S, WALLER M,

"Preliminary survey and selection of computer models suitable for energy planning applications in developing countries", 1981.  
Mitre Report MTR 81 W205 to the Commission of European Communities, ISPRA.

MUNASINHGE M, DOW M, FRITZ J,

"Microcomputers and Development",  
National Academy of Science, 1985.

SWIFT J,

"SuperCalc Professional",  
I/O Press, 1989.  
ISBN: 1-871962-00-5

UNITED NATIONS,

"Microcomputer applications for energy planning in developing countries", 1985.  
National Resources Division, Department of Technical Co-operation for Development

UNITED NATIONS,

"Application of microcomputer technology in energy planning", 1989.  
Energy Issues and Options for developing countries  
ISBN: 0-8448-1578-0



**WORKS CITED - CHAPTER 8**

AUDIT COMMISSION (U.K.),  
"Normalised Performance Indicators", 1985.

BEVAN E.G.,  
"Renewable energy technologies for power generation in the  
United Kingdom - an overview", 1990.  
International conference - Power generation and the  
environment - Institute of Mech.Engs - 13-14 November 1990

BLACK K, FIELDEN D, JACQUES J.K.,  
"An investigation of the air pollution produced by energy  
use on Guernsey", 1991.  
University of Stirling internal report

BOARD OF ADMINISTRATION,  
"A guide to home energy costs and savings' and 'Handy  
hints to help you save energy'",  
Board of Administration, 1990.

BRITISH GAS,  
"Techno-economic feasibility study for Gas Energy (CI)  
Limited - Phase Two Report", 1990.

BROWN P, FIELDEN D, JACQUES J.K.,  
"Electric Vehicles: An alternative transportation system for  
Guernsey", 1992.  
University of Stirling internal report

CAVE P.R., EVANS E.M.,  
"Tidal stream energy: Economics, technology and costs",  
1986.  
3rd International symposium on wave, tidal, OTEC and small  
scale hydro energy - 'Water for energy', Brighton, May 1986

DEPARTMENT OF ENERGY (U.K.),  
"Renewable energy in the U.K.: The way forward",  
Energy Paper No 55, 1988.

DEXTER S.G.,  
"Diesel and gas engines and the environment", 1990.  
Paper - International conference - Power generation and the  
environment - Institute of Mech.Engs. - 13-14 November 1990

ENERGY ECONOMIST ,  
"When is enough, really enough",  
Energy Economist, 1990.  
The highest rate of car ownership (worldwide) is that of the  
USA. It had 552 cars for every 1000 people in 1986.

ENERGY ECONOMIST ,  
"World Status: Fuel Cells",  
Energy Economist,  
vol. 120: 1991, pp. 15-21.

ENERGY EFFICIENCY OFFICE (UK),  
"Guidance notes for reducing energy consumption costs of  
electric motor and drive systems",  
Good practice guide No.2, 1990.

ENERGY EFFICIENCY OFFICE (UK),  
"Energy use in the domestic sector by typical end-use",  
1984.

ENERGY EFFICIENCY OFFICE (UK),  
Whole list of EEO publications, refer EEO.

EWBANK PREECE LIMITED,  
"Brief review of the SEB's future energy policy options",  
1985.

EWBANK PREECE LIMITED,  
"A review of generation development", 1989.  
Final Report - reference 80206/1334 C

FIELDEN D,  
"Visit report to the Le Rance barrage near St.Malo", 1993.  
Internal SEB report

FRENCH H.F.,  
"A global agenda for clean air",  
Energy Policy,  
July/August 1990, pp. 583-585.

GUERNSEY EVENING PRESS,  
"Change from thatch to tile made dormers worthwhile",  
24 April 1984.

GUERNSEY EVENING PRESS,  
"Nuclear industry like a cancer on this earth",  
Guernsey Evening Press,  
2 August 1985.

GUERNSEY EVENING PRESS,  
"Islands well suited to provide wave power electricity",  
Guernsey Evening Press,  
30 April 1988.

GUERNSEY EVENING PRESS,  
"French natural gas link comes closer",  
Guernsey Evening Press,  
26 March 1990.

GUERNSEY EVENING PRESS,  
"BOA want to burn tip gas",  
Guernsey Evening Press,  
13 March 1993.  
The Board of Administration want to build a £200,000 gas  
abstraction plant to get rid of methane from the Bordeaux  
tip.

INTERNATIONAL ENERGY AGENCY,  
"Electric vehicles: Technology, performance and potential",  
1993.

JESPERSEN K.D.,  
"First offshore windfarm starts up", 1991.  
Elkraft Power Company Limited, Denmark

KEHOE L, GRIFFITHS J,  
"California adopts tough pollution laws",  
Financial Times,  
1 October 1990.

MARSHALL M.R.,  
"End-use analysis of domestic electricity sales",  
Distribution Developments,  
vol. 91: no2, August 1991.

MCINNES G, UNTERWURZACHER E,  
"Electricity end-use efficiency",  
Energy Policy,  
vol. 19: no3.

MCPHERSON C.J.,  
"Electric road vehicles for island communities", 1989,  
University of Stirling - PhD thesis.

MILBANK, N.O AND SOUTHERN, J.R.,  
"Improving the thermal insulation of solid walled buildings  
in the United Kingdom",  
IEA conference on new energy conservation technologies and  
their commercialisation, Berlin.

MOORE T,  
"New ! Clean ! Electric !",  
EPRI Journal,  
vol. 16: no3, April/May 1991.

MUNDAY P.K.,  
"U.K. emissions of air pollution", 1990.  
Warren Spring Laboratory, Stevenage, Report No. LR 764

NEW SCIENTIST,  
"EDF considering diversification away from nuclear energy",  
12 January 1991.

O'CALLAGHAN P.W.,  
"Energy resources, CO2 production and energy conservation",  
Applied Energy,  
vol. 44: 1993, pp. 65-91.  
Department of Applied Energy, Cranfield Institute of  
Technology, Bedford, MK43 OAL

PINGREE R.D., MADDOCK L,  
"Tidal residuals in the English Channel",  
Journal of Marine Biology Association,  
vol. 57: 1977, pp. 339-354.

SCHUMACHER D,  
"Energy: Crisis or Opportunity",  
MacMillan Publishers Limited, 1985.  
ISBN: 0-333-27191-2  
An introduction to energy studies

STATES OF GUERNSEY,  
"SGWB 1920-70", .  
States of Guernsey Water Board history

STATES OF GUERNSEY,  
"An integrated transport and planning strategy for  
Guernsey", 1991.  
Island Traffic Committee/Island Development Committee  
(Joint Working Party).

SYSTEM THREE SCOTLAND,  
"Report of a survey on the use of domestic fuels on  
Guernsey", 1990.

WARD B,  
"Forward to 'Soft energy paths: Towards a durable peace'",  
see Works cited - Chapter 1, 1977.

**COLLECTED DOCUMENTS (CLIMATIC CHANGE AND REDUCING CO2  
EMISSIONS) - CHAPTER 8**

CLARK, W,  
"Usable knowledge for managing global climate change",  
Stockholm Environment Institute, London, 1990.

INTERGOVERNMENTAL PANEL ON CLIMATE CHANGE (IPCC),  
"Scientific assessment of climate change", 1990.  
Report prepared for IPCC by working group 1, World  
Meteorological Organisation (WMO) and United Nations  
Environment Programme (UNEP).

JACKSON, T AND ROBERTS, S,  
"Getting out of the greenhouse", 1989,  
Friends of the Earth, London,  
ISBN: 0-905966-82-1.

GERHOLM, T.R,  
"Climate and carbon dioxide: Are fossil fuels a threat to  
the environment ?", July 1991,  
World Energy Council Journal.

GREEN, D,  
"Major green role for CHP", January/February 1992,  
Energy Management, pp11.

DEPARTMENT OF ENERGY (U.K.),  
"An evaluation of energy related greenhouse gas emissions,  
and methods to ameliorate them", 1989,  
Energy Paper No 58.

THURLOW, G.G,  
"Reducing CO2 emissions", 1991,  
Energy World, Vol 185, (pp7-12).

OKKEN, P.A, SWART, R.J AND ZWERVER, S,  
"Climate and energy", 1989.  
Kluwer Academic Publishers,  
ISBN: 0-7923-0519-1.

#### WORKS CITED - CHAPTER 9

ADVISORY AND FINANCE COMMITTEE,  
"Chouet headland planning inquiry", 1988.  
Billet d'Etat XXI.

ALPER SYSTEMS LIMITED,  
Alper Systems, Cambridge Science Park, Milton Road,  
Cambridge, CB4 4WG (Now called Sysdeco (UK) Limited)

ATKINS W.S AND PARTNERS,  
1982.  
Consulting engineers to the U.K. Government

BALL R,  
"Quantitative approaches to management",  
Butterworth-Heinemann Limited, 1991.  
ISBN: 0-7506-0065-9

BROWN R.P., FIELDEN D, JACQUES J.K.,  
"Electric Vehicles: An alternative transportation system for  
Guernsey", 1992.  
University of Stirling internal report

COMBINED HEAT AND POWER ASSOCIATION,  
"A guide to the implementation of combined heat and power  
community heating systems", 1990.  
Produced by the Combined Heat and Power Association for the  
Energy Efficiency Office, UK Department of Energy

DEERING, S, NEWBOROUGH, M AND PROBERT, S. D,  
"Rescheduling electricity demands in domestic buildings",  
1993.  
Applied Energy Vol 44 (pp 1-62), Elsevier Science Publishers  
Limited.

DORGHAM M.A.,  
"Local heat and power generation: A new opportunity for  
British industry", 1982.  
Proceedings of an International conference held at the  
Open University, Milton Keynes - 16 April 1982

ENERGY EFFICIENCY OFFICE (UK),  
"Good practice guide No.13", 1990.  
Heat recovery technology (heat exchangers etc)

ENERGY TECHNOLOGY SUPPORT UNIT (ETSU),  
"A review of mass burn incineration as an energy source",  
1990.  
HMSO, ETSU-R-57.

EWBANK PREECE LIMITED,  
"Review of generation development", 1989.  
Final report - reference 80 206/1334 C.

FIELDEN, D, JACQUES, J.K AND LAROCQUE, M,  
"Electricity demand and supply matching for the parish of  
Castel, Guernsey", 1992.  
University of Stirling internal report.

GUERNSEY EVENING PRESS,  
"Pollution on Guernsey beaches",  
6 March 1991.  
GUERNSEY EVENING PRESS,  
"The eye of the beholder", 23 January 1992.

GUERNSEY EVENING PRESS,  
"Siting wind turbines", 24 January 1992.

GRUBB M.J.,  
"The integrated analysis of new energy sources on the  
British supply system: Methods and application", 1987.  
Fifth International conference on energy options -  
7-9 April 1987 - University of Reading

GRUBB M.J.,  
"The integration of renewable electricity sources",  
Energy Policy,  
September 1991.

HALL, J.E,  
"Alternative uses for sewage sludge", 1991.  
Pergamon Press,  
ISBN: 0-08-040271-2.

HOUSE OF COMMONS,  
"Third report - Combined Heat and Power", April 1983.  
Select Committee on Energy.

HOUSE OF LORDS,  
"Air pollution from municipal waste incineration plants",  
1989.  
Select Committee on the European Communities - HL Paper  
17, HMSO.

JACKSON M,  
"Advanced spreadsheet modelling with Lotus 123",  
John Wiley and Sons Limited, 1988.  
ISBN: 0-471-91989-6

JACQUES, J.K, LESOURD, J.B AND RUIZ, J.M,  
"Modern applied energy conservation", 1988.  
Ellis Horwood,  
ISBN: 0-7458-0268-0.

JESPERSEN K.D.,  
"First offshore windfarm starts up", 1991.  
Elkraft Power Company Limited, Denmark

RICHARDS, K,  
"Power generation from landfill gas", February/March 1990.  
Energy Management (p 25).

RICHARDS, K,  
"Landfill gas - A global review", 1989.  
Paper presented to seventh international biodeteriation  
symposium, Emmanuel College, Cambridge.

RICHARDS, K,  
"All gas and garbage", 3 June 1989.  
New Scientist

LEE, T, WREN, B AND HICKMAN, M,  
"Public responses to the siting and operation of wind  
turbines", 1989.  
Robens Institute and Department of Psychology, University of  
Surrey.

MARSHALL W,  
"Report to the Secretary of State by the Combined Heat and  
Power Group", 1979.  
Energy paper No.35

MASS ENERGY LIMITED,  
Mass Energy Limited, South Road, Aston Fields, Bromsgrove,  
Worcester, B60 3EW

O'BRIAN ENERGY EUROPE LIMITED,  
O'Brian Energy Europe Limited, Premier House, 15 Wheeler  
Gate, Nottingham, NG1 2NN - Personal communications

ROST P,  
Hansard,  
25 February 1980.

ROSLUND, S,  
"Computer aided planning of CHP/DH systems", June 1983.  
A paper presented at the District Heating Association fifth  
national conference, Torquay.

STATES OF GUERNSEY,  
"Waste management strategy for Guernsey", 1989.  
Land Use Consultants, 43 Chalton Street, Euston, London,  
NW1 1JB

SWIFT-HOOK, D.T,  
"Land energy and the environment", 1989.  
Peter Peregrinus Limited,  
ISBN: 0-86341-176-2.

TOTAL (SARNIA) LIMITED,  
Total (Sarnia) Limited, Northside, Vale, Guernsey

WEBB, J,  
"Can we learn to love the wind", 16 July 1994.  
New Scientist, Vol 142 (pp 12-14).  
Looks at the debate over acceptability of wind farms,  
whether wind farms are just noisy eyesores or a serious  
source of Britain's electricity.

#### COLLECTED DOCUMENTS (COGENERATION) - CHAPTER 9

BILL, C,  
"The application of diesel engine and gas turbine prime  
movers to combined heat and power", 26-27 September 1989.  
Paper presented at the Independent Power Generation  
Conference, Heathrow Park Hotel, London.

DEPARTMENT OF ENERGY (U.K.),  
"Heat loads in British cities", 1979.  
Energy Paper No 34, HMSO.

DEPARTMENT OF ENERGY (U.K.),  
"Combined heat and electrical power generation in the United  
Kingdom", 1979.  
Energy Paper No 35, HMSO.

ENERGY EFFICIENCY OFFICE (U.K.),  
"Introduction to small scale combined heat and power", 1990.  
Good practice guide No 3.

ENERGY EFFICIENCY OFFICE (U.K.),  
Guidance notes for the implementation of small scale  
packaged combined heat and power', 1989.  
Good practice guide No 1.

MARECKI, J,  
"Combined heat and power generating systems", 1988.  
Peter Peregrinus Limited,  
ISBN: 0-86341-113-4.



WORKS CITED - CHAPTER 10

- ADVISORY AND FINANCE COMMITTEE,  
"1991 Policy planning, economic and financial report", 1991.  
Section 2.70
- ALLAN R, BILLINGTON R,  
"Power system reliability and its assessment",  
Power Engineering Journal,  
November 1992.
- BANTELMAH, H, KOCHS, H.D AND ZIMMER, H,  
"The design of a modern total-energy control centre", August  
1990.  
ETZ, Vol 111, No 15 (pp 794, 796-8) (in german).  
The authors describe the new control centre installed by the  
Stadtwerke Wiesbaden, Germany, for the combined control of  
its electricity, gas and district heating services (the core  
of the system is a dual computer installation).
- BESSELY M.E., LITTLECHILD S.C.,  
"The regulation of privatised monopolies in the United  
Kingdom",  
Rand Journal of Economics,  
vol. 20: no3, Autumn 1989.
- BOARDMAN B,  
"Opportunities and constraints posed by fuel poverty on  
policies to reduce the greenhouse effect in Britain",  
Applied Energy,  
vol. 44: 1992, pp. 185-195.  
Elsevier Science Publishers Limited
- BURGELMAN, R.A AND MAIDIQUE,  
"Strategic management of technology and innovation", 1988.  
Irwin Inc.  
ISBN: 0-256-03481-8.
- ELECTRIC POWER ENGINEERS JOURNAL,  
"Ideology once again threatens staff", March 1994.  
With 81% of electricity sold by contract, what real impact  
have pool prices on electricity costs in any case ?
- GUERNSEY EVENING PRESS,  
"Channel Television phone-in",  
5 March 1993.
- GUERNSEY EVENING PRESS,  
"Channel's nuclear 'Non'",  
5 March 1993.
- GUERNSEY EVENING PRESS,  
"Support grants could amount to £7.5 million in next six  
years", 4 November 1988.
- GUERNSEY EVENING PRESS,  
"States cash backs grower investment", 22 July 1989.

HENRY J, WALKER D,  
"Managing innovation", 1991.  
The Open University  
ISBN: 0-8039-8505-3

LOVERIDGE, R AND PITT, M,  
"The strategic management of technological innovation",  
1990.  
John Wiley and Sons Limited,  
ISBN: 0-471-92499-7.

OWEN R.G., BROGAN R,  
"The effect of optimising the level of domestic thermal  
insulation on the economics of district heating", 1979.  
A paper presented at the District Heating Association's  
3rd national conference - April 1979, Eastbourne

PUTNAM, HAYES, BARTLETT,  
1991.  
Report on conference on reconstruction/privatisation,  
Moscow, 4-5 September 1991

QUALI, A AND FANTIN, J,  
"Optimal decentralised control for multi-machine power  
systems", 1990.  
Electrical Machine Power Systems (USA), Vol 17, No 4-5  
(pp 259-68).

ROGERS B,  
"Control distribution networks with embedded generators",  
1994.  
A one day conference - 24 May 1994 - London Hilton on Park  
Lane Hotel, London, W1

SCHLESINGER J,  
"The ebb and flow of government intervention in oil  
markets", 1991.  
Sixth international energy conference - Chatham House,  
2 December 1991

SCHRAMM G,  
"Marginal cost pricing revisited",  
Energy economics,  
vol. 13: no4, October 1991.

STATES OF GUERNSEY,  
"An integrated transport and planning strategy for  
Guernsey", 1991.  
Island Traffic Committee/Island Development Committee  
(Joint working party)

SUMMERTON J, BRADSHAW T.K.,  
"Towards a dispersed electrical system - challenges to the  
grid",  
Energy Policy,  
January/February 1991, pp. 24-33.  
Butterworth-Heinemann Limited

TOBIN N.P., GLYNN B,  
"Distribution system losses are evaluated by measurement",  
Transmission and Distribution International,  
December 1991, pp. 40-43.

TOMBS F,  
"Vacuum at the centre",  
Electricity UK,  
no12, January 1993.

VICKERS J, YARROW G,  
"Regulation of privatised firms in Britain",  
European Economic Review,  
no32, 1988, pp. 465-472.

VICKERS J, YARROW G,  
"Privatisation: An economic analysis", 1988.  
Massachusetts Institute of Technology  
ISBN: 0-262-22033-4

WEBB M.G.,  
"Energy pricing in the U.K.",  
Energy economics,  
October 1980, pp. 194-198.

WYMAN V,  
"Power failure in the free market",  
The Engineer,  
vol. 275: no7106, 2 July 1992.  
Two leading academics (Ian Fells and Nigel Lucas) are  
calling on the UK Government to abandon its strict free-  
market approach to energy as irrelevant and damaging.

#### WORKS CITED - CHAPTER 11

ADVISORY AND FINANCE COMMITTEE,  
Billet d'Etat XVI,  
States of Guernsey, 1988, 610 pp.

ADVISORY AND FINANCE COMMITTEE,  
Billet d'Etat XXII,  
States of Guernsey, 1991.  
Wednesday 31 July 1991

ADVISORY AND FINANCE COMMITTEE,  
"Budget 1992",  
States of Guernsey, 1992.

ANDREWS D.C., LOWE R.J.,  
"The economics and relevance of medium, small and micro  
combined heat and power/district heating", 1983.  
Energy Research Group, The Open University, Milton Keynes

BELDING J.A.,  
"Cogeneration", 1982.

BLACK K., FIELDEN D., JACQUES J.K.,  
"An investigation of the air pollution produced by energy  
use on Guernsey", 1991.  
University of Stirling internal report

CASSELS J.M.,  
"Some remarks about district heating network costs", 1980.

COMBINED HEAT AND POWER ASSOCIATION,  
"Guide to the implementation of combined heat and power  
community heating schemes",  
Combined Heat and Power Ass., 1990.  
Produced by the Combined Heat and Power Association for the  
Energy Efficiency Office, U.K. Department of Energy

CONFERENCE ON SHIPPING,  
"Proceedings of a conference on shipping held at the  
University of York", 1989.

DEPARTMENT OF THE ENVIRONMENT (U.K.),  
"Introduction to energy efficiency in schools", 1994.  
HMSO.

DEPARTMENT OF THE ENVIRONMENT (U.K.),  
"Energy efficiency in council housing: Guidance for local  
authorities", 1994.  
HMSO.

DEPARTMENT OF THE ENVIRONMENT (U.K.),  
"Attitudes to energy conservation in the home: Report on a  
qualitative survey", 1991.  
HMSO.

DEPARTMENT OF ENERGY (UK),  
"District heating combined with electricity in the United  
Kingdom", 1977.  
Energy Paper No. 20

EDWARDS P.D., MILBORROW D.J.,  
"Delabole wind farm",  
Modern Power Systems,  
vol. 12: no10, October 1992.

ENERGY EFFICIENCY OFFICE (U.K.),  
"Energy efficient renovation of houses", 1986.  
HMSO.

ENERGY EFFICIENCY OFFICE (U.K.),  
"Energy efficiency in hotels: A guide for owners and  
managers", 1994.

ENERGY EFFICIENCY OFFICE (U.K.),  
Energy management 'focus' pamphlets.

EVANS R.,  
"Environmental and economic implications of small-scale  
CHP",  
Energy Policy,  
vol. 21: no1, January 1993.  
Butterworth-Heinemann Limited

EWBANK PREECE LIMITED,  
"A review of generation development", 1989.  
Final report - reference 80206/1334C

FIELD, A,  
"Energy consumption in office buildings", March/April 1992.  
Energy Management.

FRIEDMAN L.S., WEARE C.,  
"The two-part tariff practically speaking",  
Utilities Policy,  
January 1993, pp. 62-80.

GUERNSEY EVENING PRESS,  
"Start saving for a sewage plant plea",  
6 March 1991.  
Arendt, P.

GUERNSEY EVENING PRESS,  
"Green up lungs of the corridor",  
18 April 1992.  
Fletcher, P.G.

GUERNSEY EVENING PRESS,  
"Micky Mouse power cut",  
4 June 1994.

GUERNSEY EVENING PRESS,  
"Heat saving methods", 25 July 1979.  
Horticulture Advisory Service.

GLYNN D.R.,  
"The mechanisms of price control",  
Utilities Policy,  
vol. 2: n2, April 1992.  
Butterworth-Heinemann Limited.

GRUBER E., BRAND M.,  
"Promoting energy conservation in small and medium sized  
companies",  
Energy Policy,  
vol. 19: no3, April 1991.  
Butterworth-Heinemann Limited

JACCARD M., SIMS D.,  
"Employment effects of electricity conservation: The case of  
British Columbia",  
Energy Studies Review,  
vol. 3: no1, 1991.

LAINE J.L., BERLINER T., COLEMAN M.A.,  
"Variable spot pricing with transtext", 1991.

LIND R.C.,  
"Discounting for time and risk in energy policy",  
Resources for the future Inc., 1982.  
ISBN: 0-8018-2709-4

MACADAM J.A., JEBSON D.A., OWEN R.G. et al.,  
"District heating combined with electricity generation: A  
study of some of the factors which influence cost-  
effectiveness", 1981.

MOE M.L.,  
"What a well equipped customer can do to shift energy use",  
1991.  
Demand side management conference, Wynham Hotel and  
Conference Center, Palm Springs California, 14-16 January

MONNIER E., GASKELL G., ESTER P. et al.,  
"Consumer behaviour and energy policy",  
Praeger Publishers, 1987.  
ISBN: 0-275-92179-4

PARKS T.,  
"Whats the connection between home systems and the electric  
utilities ?", 1991.

REDDY A.K.N.,  
"Barriers to improvements in energy efficiency",  
Energy Policy,  
vol. 19: no10, December 1991, pp. 953-961.

ROBINSON E.D.,  
"Demand side management includes electric transportation",  
Transmission and Distribution,  
vol. 45: no8, August 1993, pp. 34-38.

SHEFFIELD HEAT AND POWER LTD,  
"personal communications - S.Brooks - Development Manager",  
1992.  
Sheffield Heat and Power Limited, Unit 12, Sheffield Science  
Park, Howard Street, Sheffield, S1 2LX

THOMSON L,  
"Reporting changes in the electricity supply industry and  
privatisation", May 1993.  
Financial Accountability and Management,  
vol. 9: no2, Basil Blackwell Limited.

THOMSON L.,  
"The financial and accounting implications of the  
privatisation of the regional electricity companies in the  
U.K.", January 1993.  
Utilities Policy, pp. 9-23.

THOMSON L.,  
"Accounting and regulation in the privatised electricity supply sector in England and Wales", 1994.  
A paper submitted to the 17th Annual Congress of the European Accounting Association - 6-8 April - Venice, Italy

U.K. GOVERNMENT,  
"Command Paper 7131",  
London, HMSO, 1978.

U.K. GOVERNMENT ECONOMIC SERVICE,  
"The test discount rate and the required rate of return",  
1979.  
Working Paper 2, U.K. Treasury, London.

VERBUGGEN A., WIGGIN M., DUFAIT N. et al.,  
"The impact of CHP generation on CO2 emissions",  
Energy Policy,  
vol. 20: n12.  
Butterworth-Heinemann Limited  
WILLIAMS R.H.,  
"Industrial Cogeneration", 1978.

WIRL F.,  
"Needle peaking caused by time of day tariffs",  
Electrical Power and Energy Systems,  
vol. 13: no3, June 1991, pp. 175-181.  
Butterworth-Heinemann Limited

WOODWARD A.,  
"Financing waste to energy plants",  
Energy Economics,  
vol. 14: no3, July 1992, pp. 233-236.

#### WORKS CITED - CHAPTER 12

ADVISORY AND FINANCE COMMITTEE,  
Billet d'Etat XVI,  
Wednesday 26 September 1990

ADVISORY AND FINANCE COMMITTEE,  
Billet d'Etat XVI,  
Wednesday 10 July 1991

ADVISORY AND FINANCE COMMITTEE,  
"1992 Policy planning, economic and financial report",  
1992.

ADDIS J.M.,  
"Personal communications", 1991.  
Committee Clerk, Policy and Resources Committee, States Building, States Greffe, St. Helier

CRAGG C.,  
"24 August: Crisis in the Gulf",  
Utilities Policy,  
October 1990, pp. 5-8.

ECONOMIST,  
"The price of everything, the value of nothing",  
Economist,  
31 July 1993.

EMSTAR LIMITED,  
Emstar Limited, Elizabeth House, 56/60 London Road, Staines,  
Middlesex, TW18 4BQ

ELECTRIC POWER RESEARCH INSTITUTE,  
"Preliminary report TR - 102461", 1993.  
Distribution utility evaluation report.

ELECTRIC POWER RESEARCH INSTITUTE,  
"Inclusion of cogeneration in electric utility models",  
September 1980.

ELECTRIC POWER RESEARCH INSTITUTE,  
"Cogeneration and central station generation", October 1981.

EWBANK PREECE LIMITED,  
"Brief review of the SEB's future energy policy options",  
15 April-10 May 1985.

EWBANK PREECE LIMITED,  
"A review of engineering development", 1989.  
Final report - reference 80206/1334C

FERNANDES R.,  
"Cogeneration and energy storage systems at the distribution  
level", 1994.  
Paper presented at the international conference - Managing  
energy distribution and demand - 27-29 September - Paris

GUERNSEY EVENING PRESS,  
"Extra £2 m on growers fuel bill expected",  
11 July 1979.

GUERNSEY EVENING PRESS,  
"Cold adds 30% to growers fuel bills",  
19 February 1985.

GUERNSEY EVENING PRESS,  
"Anxious growers watch Gulf",  
15 August 1990.

INTERNATIONAL ENERGY AGENCY,  
"World energy outlook to the year 2010", 1993.  
International Energy Agency, 1-71 pp.  
Forecasts energy demand to 2010



INSIDE ENERGY,  
"Outsourcing energy management",  
Inside Energy,  
vol. 4: n5, August 1993, pp. 6-7.  
Discusses a concept imported from the USA in the mid-1980s  
called 'Contract Energy Management (CEM)': What it is and  
what it does.

ISLAND TRAFFIC COMMITTEE/ISLAND DEVELOPMENT COMMITTEE,  
"An integrated transport and planning strategy for  
Guernsey",  
States of Guernsey, 1991.  
A Statement of Vision (Joint working party)

LUTZ E.,  
"Toward improved accounting for the environment",  
World Bank, 1993.

ROTTY R.M., VAN ARTSDALEN E.R.,  
"Thermodynamics and its value as an energy policy tool",  
Energy,  
vol. 3: 1978, pp. 111-117.  
Pergamon Press

STATES OF GUERNSEY,  
"Transport study, transport survey - technical report",  
1988.

STATES OF GUERNSEY,  
"Transport study, transport survey - survey report", 1988.

SUNDAY TIMES,  
"Who is getting rich from the oil crisis",  
30 September 1990

SUNDAY TIMES,  
"The crisis in the gulf has pushed up oil prices and thrown  
world stock markets into turmoil",  
12 August 1990

TINSON R.,  
"All you ever needed to know and more",  
Energy in Buildings,  
January 1992, pp. 19-21.

VINE E., DE BUEN O., GOLDMAN C. et al.,  
"Mandating utility competition",  
Utilities Policy,  
vol. 2: n01, January 1992.  
Butterworth-Heinemann Limited

WORLD ENERGY COUNCIL COMMISSION,  
"Energy for tomorrow's world",  
Kogan Page, 1993.  
ISBN: 07494-1117-1

## CITED AUTHOR INDEX

Author	Chapters
Ackerman, C	7
Ackoff, R.L	3
Addis, J.M	12
Advisory and Finance Committee	1, 2, 9, 10, 11, 12
Alderney Electricity Limited	4
Allan R et al	10
Allera, S	7
Alper Systems Limited	9
Andrews, D.C et al	7, 11
Anstead, D.T et al	1
Armstrong, H et al	4
Atkins, W.S and Merz & McLellan	2
Atkins, W.S and Partners	9
Audit Commission (U.K.)	8
Ball, R	9
Bantelmann, H et al	10
Barbour, D.W	2
Barre, O	1
Beesley, M.E et al	10
Beishon, J et al	3
Belding, J.A	11
Benson, R.S	6
Berry, Wm	1
Bevan, E.G	8
Bill, C	7, 9
Black, Geoghegan and Till	4

Black, K, Fielden, D and Jacques, J.K	8, 11
Board of Administration	8
Boardman, B	10
Bolland, H	1
British Fuels Limited	4
British Gas	4, 5, 8
British Petroleum	2, 4, 5
Brown, R.P, Fielden, D and Jacques, J.K	5, 8, 9
Burgelman, R.A et al	10
Byer, T et al	2
Byers, R.A	7
Capros, P et al	7
Carey, E	1
Carrabis, J.D	7
Carrol, T.O	7
Carty, P	1
Cassels, J.M	11
Cave, P.R et al	8
Checkland, P.B	3
Checkland, P.B and Davies, L	3
Checkland, P.B and Scholes, J	3
Cheshire, J	1
Christensen, L.R et al	1
Clark, J.G	2
Clark, W	8
Cogeneration Systems Limited	7
Combined Heat and Power Association	9, 11
Computer Associates	7

Cragg, C	12
Crook, A.W	1
Curran, J.S	2
Das, S et al	2
Deering, S et al	9
Demangeon, A	1
De Pace, M	7
Department for Scotland	1
Department of Energy (U.K.)	1, 8, 9, 11
Department of Systems (Lancaster)	3
Department of the Environment (U.K.)	11
Dexter, S.G	8
Dicey, T	1
Dooley, T	7
Dorgham, M.A	9
Duncan, J	1
Durand, R	1
Economist	2, 12
Edwards, P.D et al	11
Elcontrol, S.P.A	6
Electrical Review	1
Electric Power Engineers Journal	10
Electric Power Research Institute (EPRI)	12
Emstar Limited	12
Energy Economist	8
Energy Efficiency Office (U.K.)	8, 9, 11
Energy Information Centre	4
Esso Petroleum Limited	4

ETSU	9
Evans, R	11
Everitt, B	6
Ewbank Preece Limited	1, 5, 8, 9, 11, 12
Fawkes, S.D et al	7
Fernandes, R	12
Fesharaki, F et al	2
Field, A	11
Fielden, D	8
Fielden, D, Jacques, J.K and Larocque, M	9
Flood, R.L et al	3
French, H.F	8
Friedman, L.S et al	11
Friends of the Earth	2
Fulkerson, W et al	2
Gas Energy (C.I.) Limited	4
Gerholm, T.R	8
Glynn, D.R	11
Goad, Chas. E	5
Green, D	8
Greenberger, M et al	3
Grubb, M.J	9
Gruber, E et al	11
Guernsey Evening Press	1, 2, 4, 8, 9, 10, 11, 12
Hafele, W	1
Hall, J.E	9
Hammond, C.J	1

Hannah, L	1
Harker, J.H et al	4
Hedley, D	1
Hein, K	7
Henry, J et al	10
Horlock, J.H	7
Horticultural Advisory Service	2
House of Commons	9
House of Lords	9
Hu, S.D	3
Hutchinson, R et al	7
Inside Energy	12
Intergovernmental Panel on Climate Change	8
International Energy Agency	8, 12
Island Traffic Committee et al	12
Jaccard, M et al	11
Jackson, M	9
Jackson, M.C	3
Jackson, T et al	8
Jacques, J.K et al	1, 3, 9
Jenkins, G.M	3
Jenkins, N	1
Jersey Electricity Company Limited	4
Jespersen, K.D	8, 9
Jones, E	7
Journal of Transport Economics & Policy	4
Kehoe, L et al	8

Kempton, W et al	7
Kilshaw, Rev Wm	2
Konis, C.Y	2
Kotas, T.J	6
Laine, J.L et al	11
Langlois, J.E	2
Leach, G	5
Lee, T et al	9
Lind, R.C	11
Liskin, M	7
Loveridge, R et al	10
Lovins, A.B	1
Lutz, E	12
Macadam, J.A et al	11
Madsen, A.E	7
Manne, A.S et al	7
Manx Electricity Authority	4
Marecki, J	9
Marshall, M.R	8
Marshall, W	9
Mass Energy Limited	9
McInnes, G et al	8
McPherson, C.J	8
Milbank, N.O et al	8
Moe, M.L	11
Monnier, E et al	11
Moore, T	8
Munasinhge, M et al	7

Munday, P.K	8
Neelamkavil, F	7
Nerlove, M	1
Newborough, M et al	7
New Scientist	8
Norweb/ETSU	1
O'Brian Energy Europe Limited	9
O'Callaghan, P.W	8
Office for Official Publications of the EU	2
Okken, P.A et al	8
Optner, S.L	3
Owen, R.G et al	10
Parks, T	11
Patching, D	3
Peat Marwick McLintock	2
Perry, R.S	1
Petroleum Times	4
Pidd, M	7
Pike, R	7
Pingree, R.D et al	8
Pinney, A.A	5
Putnam, Hayes and Bartlett	10
Quali, A et al	10
Reddy, A.K.N	11
Review of Economics and Statistics	4
Richards, K	9



Robert, C	7
Robinson, E.D	11
Rogers, B	10
Rogers, G.F.C	6
Roslund, S	9
Rost, P	9
Rotty, R.M et al	12
Sarkir, S	4
Schlesinger, J	10
Schramm, G	10
Schumacher, D	8
Scragg, D	6
Semple, F.C	1
Senge, P.M	3
Simpson, A	7
Sheffield Heat and Power Limited	11
Shell (U.K.) Limited	4
Sherwin, K	6
Slessor, M	2
Smyth, D.S et al	3
Society for Underwater Technology	2
Spence, R	7
States Committee for Horticulture	5
States Electricity Board	1, 4
States of Guernsey	1, 2, 6, 8, 9, 10, 12
States Technical Services Department	5
Summerton, J et al	10
Sunday Times	12

Swift, J	7
Swift-Hook, D.T	9
System Three Scotland	8
Thomson, L	11
Thurlow, G.G	8
Tiley, E.W	7
Tinson, R	12
Tobin, N.P et al	10
Tombs, F	1, 10
Total (Sarnia) Limited	4, 9
Tupper, F.B	1
Twidell, J.W et al	1
U.K. Government Economic Service	11
UNDP/World Bank	2
United Nations	2, 7
Van Gool, W et al	6
Verbuggen, A et al	11
Vickers, G	3
Vickers, J et al	10
Vine, E et al	12
Ward, B	8
Warren, J.P	1
Watson, R et al	3
Webb, J	9
Webb, M.G	10
Western Isles Islands Council	2
Williams, R.H	11

Wills, R.J	1
Wilson, B	3
Wirl, F	11
Woodburn, I	3
Woodward, A	11
World Energy Council Commission	2, 12
World Resources Institute et al	2
Wyman, V	10

X

Y

Z